

OPERATION AND SERVICE MANUAL

Dri-Eaz Products, Inc.
15180 Josh Wilson Rd.
Burlington, WA 98233
800-932-3030

Congratulations on your purchase of the **Dri-Eaz HVE-LL Large Loss** Extraction Unit. This instruction and parts manual is a guide for operating and servicing your **Dri-Eaz HVE-LL** equipment.

Proper operation and service are necessary to ensure the outstanding performance of this unit. When properly maintained, your unit will have a long and trouble-free life.

The following service methods outlined in this manual are detailed in a manner that operation and servicing may be performed properly and safely. Because service levels vary due to the skill of the mechanic, tools and parts availability, ensure that prior to attempting any maintenance or repair, you are familiar with the equipment and have all the proper tools to complete the task. Please call a **Dri-Eaz** service representative at 800-932-3030 for help with maintenance, repair and warranty related questions.

The headings “**WARNING**” and “**CAUTION**” are utilized to warn you that steps must be taken to prevent personal injury or damage to the equipment. Please make sure that you have read and understand these instructions entirely before proceeding with the operation of this unit.

THIS UNIT MUST BE INSTALLED BY THE DEALER THAT YOU PURCHASED IT FROM IN ACCORDANCE WITH THE DRI-EAZ INSTALLATION PROCEDURES.

This unit was manufactured **Dri-Eaz** by:

Dri-Eaz Products
15180 Josh Wilson Rd.
Burlington, WA 98233
USA



WARNING! Do not alter or modify your **HVE-LL** in any way. Use only replacement parts authorized by **Dri-Eaz**. Modifications or use of unapproved parts could create a hazard and will void your warranty. Contact a **Dri-Eaz** service representative at 800-932-3030 for assistance.

Please complete the warranty registration form at www.Dri-Eaz.com

This service and operations manual is written specifically for the **HVE-LL** unit.

Published by Dri-Eaz.
Printed in USA

HVE-LL MANUAL
DRI-EAZ P/N 49-166

The information contained in this document is subject to change without notice and does not represent a commitment on the part of **Dri-Eaz**.

All rights reserved. Copyright 2017 by **Dri-Eaz**. No part of this work may be used or reproduced in any form or means without the express written consent and permission of **Dri-Eaz**.

DRI-EAZ LIMITED WARRANTY

Dri-Eaz HVE-LL

What Does This Warranty Cover?

This warranty covers the Dri-Eaz Model HVE-LL and is provided to the original purchaser only.

How Long Does This Warranty Last?

This warranty runs for:

Two (2) years from the date of installation on parts and labor (Excluding normal maintenance items.) Factory installed original belts are covered for 500 hours. Recovery tank and frame are covered for five years. All other components including seals, O-rings and electrical components are covered for the entire two year warranty period.

What Dri-Eaz Will Do:

If a defect in materials or workmanship occurs within the warranty period, Dri-Eaz at its election will repair or replace the defective part at no charge.

What This Warranty Does Not Cover:

This warranty does not cover or apply to defects due directly or indirectly to misuse, abuse, disassembly, alteration, corrosive chemicals, improper voltage, improper fuel, fire, flood, negligence, accident, improperly or incorrectly performed maintenance or repair, or failure to perform necessary or recommended maintenance or repair (See your Owner's Manual) or if the use of this product is not in compliance with the instructions and specifications for its use. This warranty does not cover normal maintenance items such as air and oil filters, lubricants and tune up parts. Paint is not covered. Water box, recovery tank and frame are covered for five years. All other components including seals, O-rings and electrical components are covered for the entire two year warranty period. We limit all implied warranties to: Two (2) years from the installation date on parts and labor.

OTHER THAN THE WARRANTIES PROVIDED HEREIN, DRI-EAZ MAKES NO EXPRESS OR IMPLIED, ORAL OR WRITTEN WARRANTIES WITH RESPECT TO THIS PRODUCT OR WORKMANSHIP AND ALL WARRANTIES IMPLIED BY LAW INCLUDING ANY WARRANTIES OF MERCHANTABILITY OR FITNESS FOR A PARTICULAR PURPOSE ARE LIMITED TO THE DURATION OF THIS WARRANTY. **Some states do not allow limitations on how long an implied warranty lasts, so the above limitations may not apply to you.** WE SHALL IN NO EVENT BE LIABLE FOR DEATH, INJURIES TO PERSONS OR PROPERTY OR FOR INCIDENTAL, CONTINGENT, SPECIAL OR CONSEQUENTIAL DAMAGES ARISING FROM USE OF OUR PRODUCTS. **Some states do not allow the exclusion or limitation of incidental or consequential damages, so the above limitation or exclusion may not apply to you.**

How Do I Get Service?

In order to be eligible for service under this warranty you MUST do the following: (a) fill out the warranty registration card on-line within thirty (30) days of the installation of our product; (b) write or call a service representative at Dri-Eaz for a return material authorization (RMA); and (c) have the serial number available. Proof of proper maintenance may be required before warranty is granted.

Contact us at:

Dri-Eaz
15180 Josh Wilson Road
Burlington, WA 98233
Phone: 800-932-3030800-932-3030

If Dri-Eaz uncovers a defect we will repair or replace the product, at our election. Ground shipping and transportation costs will be covered by the manufacturer. Returning defective parts to the manufacturer, if required, shall be the responsibility of the purchaser. Warranty may be denied if defective parts are not returned within the allotted 30 days. If it is determined that there is no defect in the product, or that the defect resulted from causes not within the scope of our warranty, then the product will be repaired or replaced only at your request and at your expense and you must bear all shipping costs.

How Does State Law Apply?

This warranty gives you specific legal rights, and you may also have other rights which vary from state to state.

TABLE OF CONTENTS

SECTION ONE: GENERAL INFORMATION	1
CONTACT INFORMATION	2
SAFETY - WARNINGS AND CAUTIONS.....	3
SPECIFICATIONS.....	8
FUEL REQUIREMENTS.....	9
ENGINE OIL REQUIREMENTS.....	9
BATTERY CONNECTION	10
RECEIVING YOUR EXTRACTION SYSTEM	11
SECTION TWO: OPERATION	12
UNDERSTANDING THE SYSTEMS.....	13
OPERATION	16
FREEZE PROTECTION	22
SECTION THREE: SERVICE AND MAINTENANCE	25
ROUTINE MAINTENANCE CHART	26
SERVICE CHART	27
MAINTENANCE	28
GENERAL SERVICE ADJUSTMENTS.....	33
TROUBLESHOOTING.....	35
SECTION FOUR: PARTS AND ACCESSORIES	37
ILLUSTRATED PARTS LISTING	38
ELECTRICAL DIAGRAM.....	56

SECTION ONE: GENERAL INFORMATION

CONTACT INFORMATION	2
WARNINGS AND CAUTIONS	3
SPECIFICATIONS	8
TORQUE VALUES.....	8
REQUIREMENTS	9
FUEL REQUIREMENTS	9
ENGINE OIL REQUIREMENTS.....	9
BATTERY CONNECTION	10
RECEIVING YOUR EXTRACTION SYSTEM	11
ACCEPTANCE OF SHIPMENT	11
EQUIPMENT LISTING.....	11
OPTIONAL EQUIPMENT.....	11

CONTACT INFORMATION

For information about unit operation, maintenance or repair of your Dri-Eaz equipment, please contact your local distributor.

To locate a local distributor, please visit our web site: <http://www.Dri-Eaz.com/>

North American Distributors: <http://www.Dri-Eaz.com>

If you need to contact Dri-Eaz directly, for questions regarding this manual, service questions that cannot be resolved by your distributor, or other general information, please contact our service department here:

Phone: 800-932-3030

Service Email: service@legendbrands.com

Please fill in the information below so that you will have it on hand when contacting your distributor or Dri-Eaz.

Serial Number: _____

Date of Purchase: _____

Purchased From (Distributor): _____

WARNINGS AND CAUTIONS

WARNING

Dri-Eaz uses this WARNING symbol throughout the manual to warn of the possibility of physical injury or fatality. Please read all warnings carefully before operating the equipment.

CAUTION

Dri-Eaz uses this CAUTION symbol throughout the manual to warn of the possibility of damage to equipment or personal property.

FOR YOUR SAFETY

The following warning labels are on your **HVE-LL** console. These labels point out important **WARNINGS** and **CAUTIONS**, which must be followed at **ALL** times. Failure to follow these warnings could result in injury or fatality to yourself and/or others or property damage. Please follow these instructions carefully! **Do NOT remove these decals.**

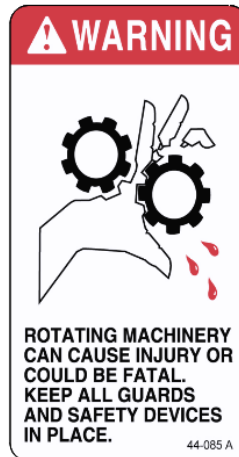
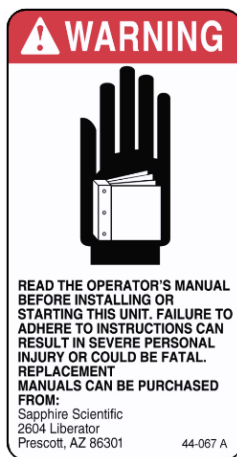
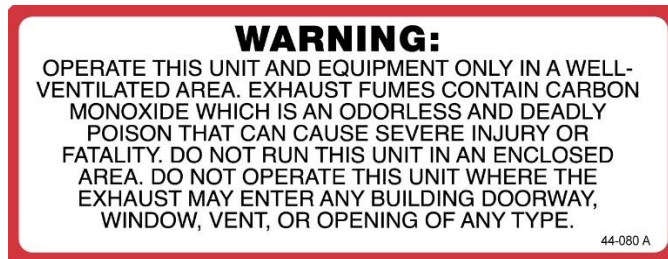

ROTATING MACHINERY. WATER UNDER PRESSURE AT HIGH TEMPERATURE. IMPROPER MODIFICATION OF EQUIPMENT CAN CAUSE SEVERE PERSONAL INJURY OR COULD BE FATAL.



 **WARNING**

1. **Read the operator's manual before starting this unit.**
Failure to adhere to instructions could result in severe personal injury or could be fatal.

 **WARNING**

2. **Operate your equipment in a well-ventilated area.**
Exhaust fumes contain carbon monoxide, which is an odorless and deadly poison that can cause severe injury or death. **DO NOT** run this equipment in an enclosed area. **DO NOT** operate this unit where the exhaust may enter a building doorway, window, vent or other opening.



 **WARNING**

3. **Gasoline is extremely flammable and its vapors can explode if ignited.** Store gasoline only in approved containers, in well-ventilated, unoccupied buildings and away from sparks or flames.

 **WARNING**

4. **DO NOT** operate unit if gasoline is spilled. Do not turn ignition switch until the gasoline has been cleaned up. Never use gasoline for cleaning purposes.

 **WARNING**

5. **DO NOT** place hands, feet, hair, clothing or any body parts near rotating or moving parts. Rotating machinery can cause severe injury or death.

 **WARNING**

6. **NEVER** operate this unit without belt and safety guards. High speed moving parts, such as belts and pulleys should be avoided while the unit is running. Severe injury, fatality and/or damage may result.

 **WARNING**

7. **NEVER** service a unit while it is running. High speed mechanical parts as well as high temperature components and fluids may result in severe injury or fatality.

 **WARNING**

8. Engine and vacuum pump components, hoses and fittings will be extremely hot from operation. To prevent severe burns, **DO NOT** touch these areas while the unit is running, or shortly after the unit is shut off.

 **WARNING**

9. **DO NOT** touch any part of the exhaust system while the system is running or for 20 minutes after the unit is shut off. Severe burns could result.

 **WARNING**

10. **Battery acid contains sulfuric acid.** To prevent acid burns, avoid contact with skin, eyes and clothing. Batteries also produce explosive hydrogen gases while charging. To prevent fire or explosion, charge batteries only in a well ventilated area. Keep sparks, open flames, as well as other sources of ignition away from battery at all times. Remove all jewelry prior to servicing batteries. Keep batteries out of the reach of children.

Before disconnecting the negative (-) ground cable, ensure that all switches are in the off position. If on, a spark could occur at the ground connection terminal which could cause an explosion if hydrogen gas or gasoline vapors are present. **ALWAYS** disconnect the negative (-) terminal first

 **WARNING**

11. **DO NOT** smoke around the equipment. Gas fumes could accumulate and ignite. Battery gasses are extremely flammable. This will prevent possible explosions.

 **WARNING**

12. **NEVER** cut or splice any of the equipment fuel lines. This will result in fuel leaks and potentially dangerous conditions. Use only the provided fuel hose for fuel lines.

 **WARNING**

13. The Occupational and Health Administration (OSHA) recommends the use of hearing protection when a technician is exposed to an average of 85 decibels (this is an average of exposure over an 8 hour period). This equipment can produce 85 decibels at a distance of 10 feet. Please check with your local state agencies to see if OSHA standards apply to your application.

 **WARNING**

14. California Proposition 65 Warning: Engine exhaust from this product contains chemicals known by the State of California to cause cancer, birth defects, or other reproductive harm.

SECTION ONE – GENERAL INFORMATION

CAUTION

1. Always keep your equipment clean and maintained. Proper performance relies heavily on regularly maintained hoses, tools, filters and strainer baskets.

CAUTION

2. Ensure that you have received proper training and are familiar with the start-up and shut-down procedures prior to operation.

CAUTION

3. **DO NOT** alter or modify your **Dri-Eaz HVE-LL** in any way. Use only replacement parts authorized by **Dri-Eaz**. Modifications or use of unapproved parts could create a hazard and will void your warranty. This includes the use of any open ended hoses.

CAUTION

4. **Do NOT** run the waste pump dry. Doing so will damage the pump impeller.

SPECIFICATIONS

Engine Speed	3000 RPM (High Speed/No Load) 1500 RPM (Idle / No Load)
Vacuum Pump RPM	3519 RPM @ 3000 Engine RPM
Vacuum Relief Valve	13 in. Hg
Waste Pump RPM	1305 RPM @ 3000 Engine RPM
Waste Pump GPM	45 GPM @ 3000 Engine RPM
Recovery Tank Capacity at Shut-Off	83 gallons
Recovery Tank Gross Capacity	93 gallons
Console/Tank Weight (empty)	700 lbs.
Console/Tank Weight (full recovery tank)	1401 lbs.

TORQUE VALUES

Engine Hub Rear	15 ft./lbs. (180 in./lbs.)
Engine Hub Front	15 ft./lbs. (180 in./lbs.)
Vacuum Pump Hub	15 ft./lbs. (180 in./lbs.)

FUEL REQUIREMENTS

Use unleaded fuel ONLY. Use only fresh, clean unleaded gasoline with a minimum octane rating of 87. **Do Not** use high octane gasoline. Gasoline with up to, not exceeding, 10% ethanol is acceptable.

Gasoline older than 30 days must be discarded and replaced with fresh gasoline.

NOTE: Using other gasoline/alcohol blends including E20 and E85 will cause damage to engine components and will void the warranty.

NOTE: The Dri-Eaz HVE-LL is equipped with a fuel cell for open air operation, it is not to be used in an enclosed space. This includes but not limited to vans, trailers, storage units or inside a facility. When operating on the fuel cell supplied with the unit equipment must be placed outside in an open air environment.

Do not fill the fuel cell in any enclosed space. Remove the entire unit or fuel cell before fueling.

For bolt in permanent installations of equipment in a vehicle a certified fuel tap system engineered for the make and model must be used.

ENGINE OIL REQUIREMENTS

Use high-quality oil of at least API (American Petroleum Institute) service class SG, SH, SJ or higher. **Do not use additives.** High quality 30W oil is recommended. A 10-30 synthetic blend may be used after 50 hours of operation for a new or rebuilt engine to allow the piston rings to properly seat. It is never recommended to extend oil change intervals past 100 hours.

Engine oil capacity	1.8 L
	1.9 US qts

Tightening torque	Drain Plug	13.6 N·m
		1.4 kgf·m
		10.0 lbf·ft

BATTERY CONNECTION



Explosive gases, Dangerous gases!

Batteries contain sulfuric acid. To prevent acid burns, avoid contact with skin, eyes and clothing. Batteries also produce explosive hydrogen gases while charging. To prevent fire or explosion, charge batteries only in a well ventilated area. Keep sparks, open flames, as well as any other sources of ignition away from batteries at all times. Remove all jewelry prior to servicing batteries. Keep batteries out of the reach of children.

Before disconnecting the negative (-) ground cable, ensure that all switches are in the OFF position. If ON, a spark could occur at the ground connection terminal, which could cause an explosion if hydrogen gas or gasoline vapors are present. ALWAYS disconnect the negative (-) terminal first.

A. Attach the red positive (+) battery cable from the starter solenoid on the console to the positive (+) terminal on the battery and tighten down the nut.

B. Attach the black negative (-) battery cable from the ground on the console to the negative (-) terminal on the battery and tighten down the nut

RECEIVING YOUR EXTRACTION SYSTEM

ACCEPTANCE OF SHIPMENT

Your Dri-Eaz HVE-LL system was thoroughly tested, checked and inspected in its entirety prior to leaving our manufacturing facility. When receiving your unit, please make the following acceptance check:

1. The unit should not show any signs of damage. If there is damage, notify the deliverer immediately.
2. Carefully check your equipment. The HVE-LL system should arrive with the following items as well as any additional optional accessories you may have ordered:

EQUIPMENT LISTING

- HVE-LL console
- HVE-LL recovery tank
- Operation and service manual
- Recovery tank 3 in. air filter
- Stainless steel strainer basket
- 200 ft. length of 2 in. vacuum hose
- One 50 ft. length of layflat hose
- Group 24 battery holder
- 12 gallon fuel tank
- Toolbox
- 45 in. hose reel
- 23 in. hose reel
- Fuel pump and filter
- Fuel line extension
- Extraction Wand
- Owner's manual

SECTION TWO: OPERATION

UNDERSTANDING THE SYSTEMS

VACUUM SYSTEM	13
WASTE PUMP SYSTEM	15

OPERATION

PREPARATION	16
INSTRUMENT PANEL READINGS AND SETTINGS.....	19
STARTING THE UNIT.....	21
AUTOMATIC WASTE PUMP.....	21
EXTRACTION PROCESS	21
SHUT-DOWN AND DAILY MAINTENANCE	22
AUTOMATIC SHUT DOWNS.....	23

FREEZE PROTECTION

WINTERIZING YOUR UNIT	24
-----------------------------	----

UNDERSTANDING THE SYSTEMS

NOTE: Read and understand this section of the manual entirely before proceeding.

Prior to proceeding into the operations and maintenance sections of this manual it is recommended that you acquire a basic understanding of how the unit functions.

VACUUM SYSTEM

The flow of vacuum is initiated by the vacuum pump, which draws air through the recovery tank. A mixture of air and water is drawn into the recovery tank through a vacuum inlet near the front of the machine. Behind this inlet is a pre-filter box, which contains a strainer basket to stop the majority of larger debris from entering the recovery tank. The air and water continue to the recovery tank to a secondary strainer basket. Here in the recovery tank, water and air separate. Water is deposited into the recovery tank while the air exits through a 100 mesh filtration system, into the vacuum pump. A relief valve is installed for vacuum pump protection.

The air is discharged from the vacuum pump through a spiral silencer which then exits through the exhaust pipe on the front of the unit.

A high level shut off sensor is located on the front of the recovery tank and will shut down the unit before the tank is at full capacity. This protects the vacuum pump from water damage.

Note: Recovery tank high level shut off will not shut the unit off due to high levels of foam.

CAUTION

Do not alter the vacuum speed outside the recommended range shown in this manual. Doing so can result in severe damage to the unit and voidance of warranty.

CAUTION

Recovery tank level shut-off will not detect high foam levels. Foam entering the vacuum pump can cause damage to the unit. The use of a quality defoamer is recommended.

A red indicator lamp will illuminate to alert the operator when the tank is full, the unit will shut down and the waste water needs to be disposed of before the operation can continue.

IN ACCORDANCE WITH EPA, STATE AND LOCAL LAWS, DO NOT DISPOSE OF WASTE WATER INTO GUTTERS, STORM DRAINS, STREAMS, RESERVOIRS OR ANY NON-COMPLIANT RECEPTACLE.

Always check local laws and regulations regarding “gray” water disposal. The penalties for non-compliance can be serious.

VACUUM SYSTEM DIAGRAM

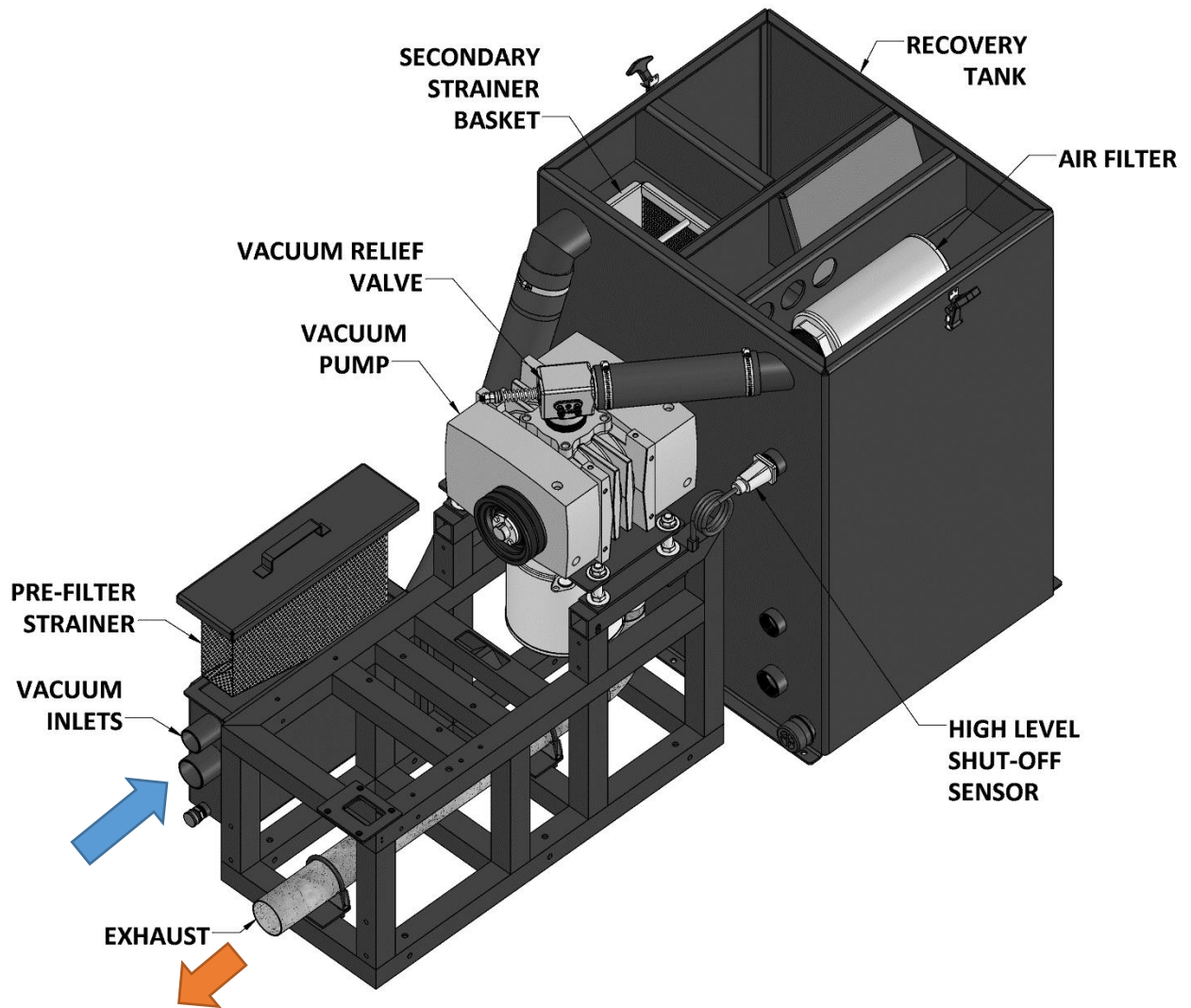

WASTE PUMP SYSTEM

The Dri-Eaz HVE-LL is equipped with an automatic waste pump-out system which removes water from the recovery tank so that the unit can continue to extract larger volumes of water than the recover tank can hold.

When turned on, the waste pump is automatically activated by a water level sensor in the recovery tank. This sensor prevents the pump from running dry and only activates the pump when there is enough water in the recovery tank to begin the removal process. Water is pumped from the supply port on the recovery tank, through the pump and out the outlet fitting.

A shut-off valve is connected to the pump to prevent leaking when not in use. Never run the pump with the valve in the off position. Running the pump dry will cause severe damage to the pump.

The recovery tank is also supplied with a manual drain port. The manual drain port must be used to drain remaining water and debris from the bottom of the recovery tank between jobs and during periods of storage.

During cold weather, with the unit turned OFF, drain remaining water from the pump by loosening the thumb screws on the impeller access panel and pulling the panel away from the pump slightly to let the water drain out. This will prevent damage that can be caused to the pump by freezing.

WASTE PUMP SYSTEM DIAGRAM

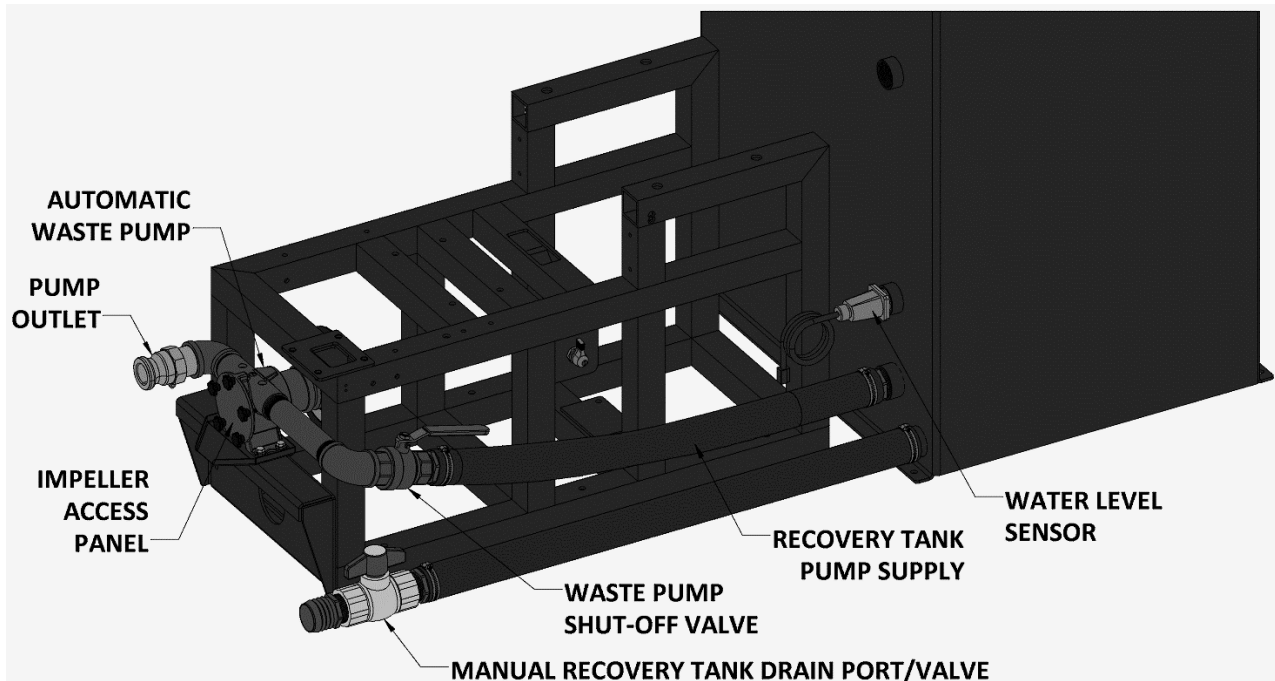

OPERATION

This section of the operator’s manual explains how to prepare, start, operate, shut down and maintain your **HVE-LL** direct-drive cleaning unit. The **HVE-LL** unit is easy to operate, however only trained operators should proceed.

⚠ WARNING Operate this unit and equipment only in a well-ventilated area. Exhaust fumes contain carbon monoxide, which is an odorless and deadly poison that can cause severe injury or death. DO NOT run this unit in an enclosed area. DO NOT operate this unit where the exhaust may enter a building doorway, window, vent or any other opening.

PREPARATION

ENSURE THERE IS ADEQUATE FUEL

Ensure there is adequate fuel to complete the job.

USING THE FUEL CELL

The Dri-Eaz HVE-LL is equipped with a fuel cell for open air operation, it is not to be used in an enclosed space. This includes but not limited to vans, trailers, storage units, box trucks or inside a facility.

If running the unit in an enclosed truck, van or trailer, the fuel tank must be removed from the enclosed space and set outside prior to operating the unit. Place the fuel tank away from heat sources and in an area where it will not be damaged or tipped over. The fuel tank must be no more than 5 feet lower than the base of the unit.

Loosen the thumb screws in the unit frame cradle to remove the fuel tank. Make sure that the fuel line is disconnected from the tank before removing.

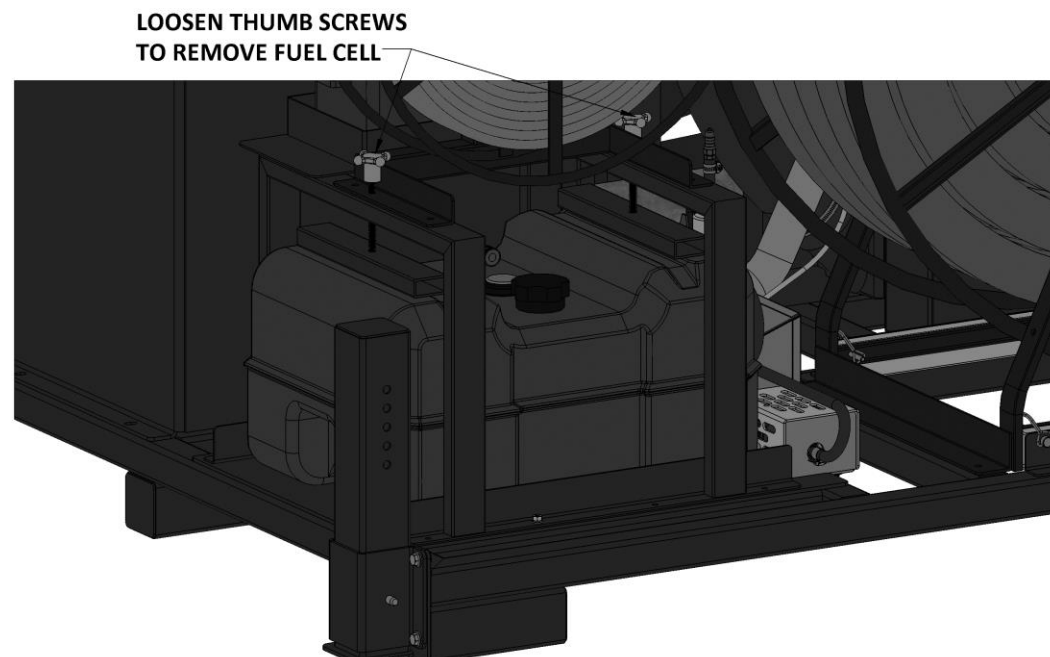

SECTION TWO – OPERATION

Using the supplied extended fuel line kit, connect the hose between the fuel tank and the unit, making sure the quick disconnects are securely fastened.

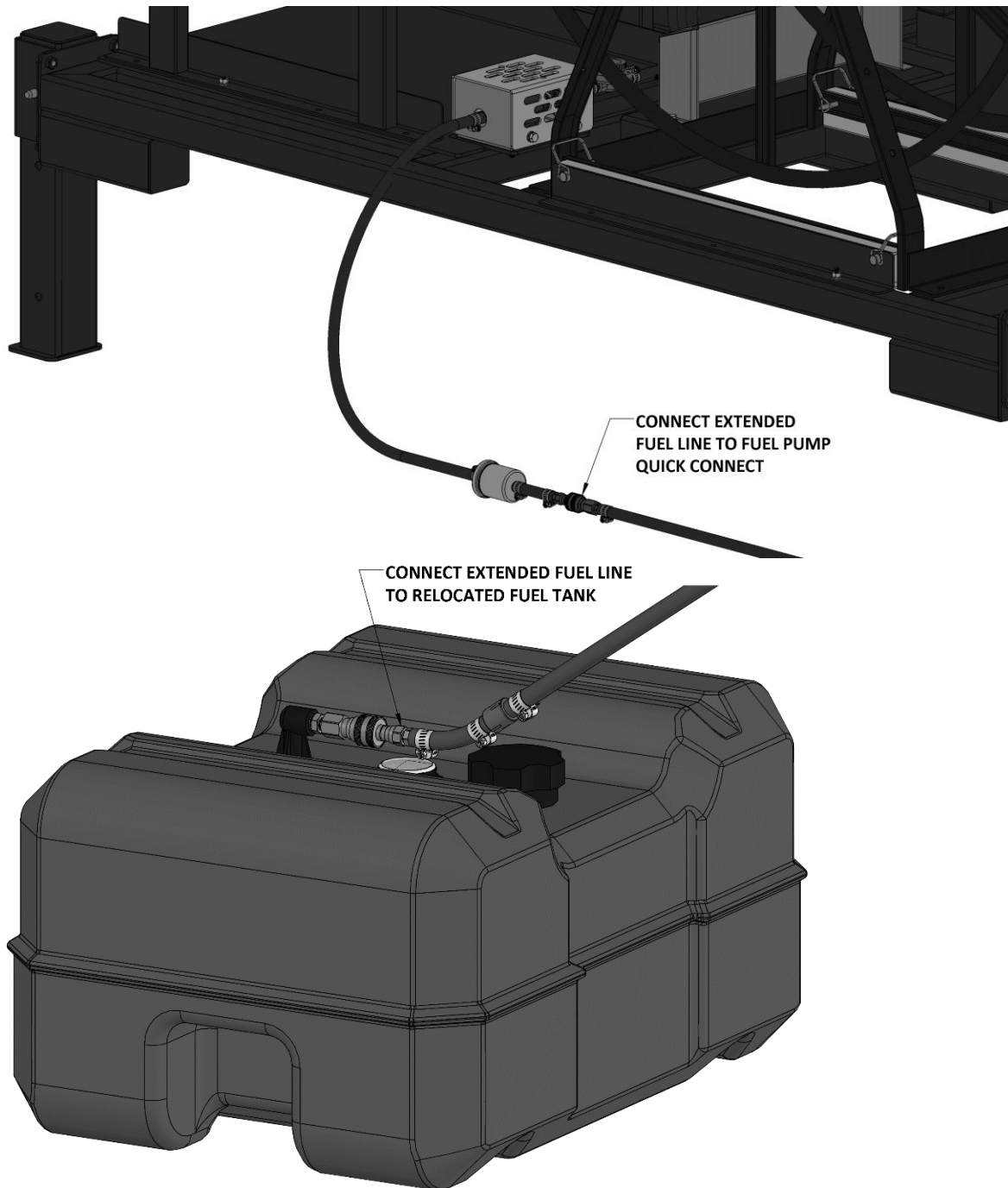

NOTE: It will take several minutes for the fuel pump to deliver fuel to the unit.

Do not fill the fuel cell in any enclosed space. Remove the entire unit or fuel tank before fueling.

For bolt in permanent installations of equipment in a vehicle a certified fuel tap system engineered for the make and model must be used.

RETURNING THE FUEL TANK

To return the fuel tank to the unit, disconnect the extended fuel line from the tank only. Start the unit with the tank disconnected to draw as much residual fuel from the line. Allow the unit to run in idle until it runs out of fuel. Disconnect the extended fuel line from the unit and replace the fuel tank into the cradle on the unit frame. Reconnect the fuel hose from the fuel pump to the tank.



Do not operate machine with covers or guards removed.

CHECK YOUR DRAIN VALVES

Make sure the recovery tank and pre-filter box drains are closed.

CHECK FILTERS

Inspect the vacuum inlet filter and strainer basket in the recovery tank. Inspect the strainer basket inside the pre-filter box. See the Shut Down and Daily Maintenance section below for more information.



NEVER operate the unit with the recovery tank air filter removed, damaged or not properly installed.

INSTRUMENT PANEL READINGS AND SETTINGS

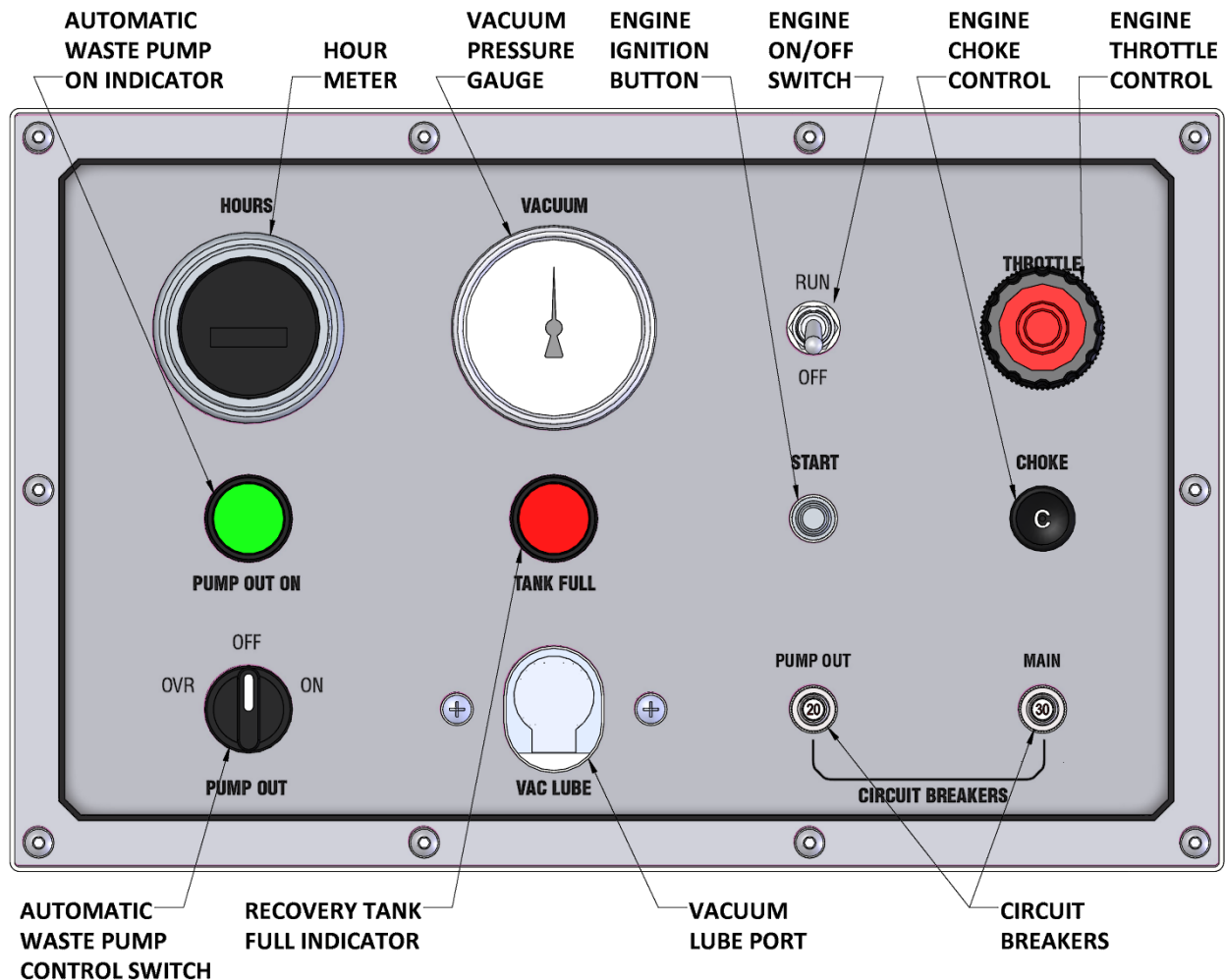

HOUR METER

The hour meter records the operating time of the machine. This information is used to calculate maintenance and service intervals. See the Service And Maintenance section in this manual for more information.

VACUUM GAUGE

With the unit running, the vacuum gauge should read near zero with vacuum hoses disconnected from the pre-filter box. If the gauge shows a reading, check the filter in the recovery tank and the strainer baskets in both the recovery tank and pre-filter box for debris. With vacuum ports sealed, and machine running at high speed, the vacuum gauge should read 11 to 13 inches of mercury (in. Hg). This is preset for the maximum safe operation.



DO NOT exceed 13 in. Hg vacuum pressure. This can cause damage to the vacuum pump.

SECTION TWO – OPERATION

PUMP OUT ON (INDICATOR LIGHT)

The pump out indicator light will turn on when the automatic waste pump is activated in either the ON or OVR positions on the PUMP OUT switch.

TANK FULL (INDICATOR LIGHT)

The tank full indicator light will turn on when the high level sensor switch has been activated in the recovery tank. The unit will shut down if running when this light comes on. Empty the recovery tank to restore operation and turn this indicator light off.

PUMP OUT SWITCH (ON/OFF/OVR)

The pump out switch is used to turn the pump on, off or temporarily on using the OVR position, which overrides the float switch in the recovery tank. Override is only used for a very short period when needed to evacuate standing water from the pump and line from the recovery tank.



Running the pump dry for any length of time will cause damage to the pump impellers and void your warranty.

VAC LUBE

The vacuum relief valve lubrication port is used to deliver lubrication to the vacuum pump. This prevents rust from building up inside the pump. See the shut-down and daily maintenance sections for more information.

RUN/OFF TOGGLE SWITCH

The run/off toggle switch allows the engine to start when switched to RUN.

ENGINE START BUTTON

The engine start button provides ignition to start the engine when pressed. The RUN/OFF toggle switch must also be set to RUN for the engine to operate.

THROTTLE CONTROL

The engine throttle control knob. Turn counter-clockwise to open the throttle (faster speed), clockwise to close the throttle (slower speed). For emergency slow-down, depress the center button and push the throttle control in.

CHOKE CONTROL

The engine choke control knob. Pull to open the choke for engine ignition.

CIRCUIT BREAKERS

Main and waste pump circuit breakers.

STARTING THE UNIT

STARTING THE ENGINE

1. Set the **THROTTLE** control in, pull out engine **CHOKE**.
2. Flip the engine on/off switch to **RUN**, press the **START** button to start the engine.
3. Once the engine is running, push in the engine **CHOKE**.
4. Set the **THROTTLE** to the desired speed.

NOTE: Do not operate the unit with the throttle set below 50% of maximum throttle setting.

CONNECT THE VACUUM HOSE

Connect the vacuum hose to the vacuum inlet connection at the front of the console on the pre-filter box. Connect the opposite end of the vacuum hose to the extraction tool. Make sure that the port you are not using is capped.

AUTOMATIC WASTE PUMP

When using your automatic waste pump:

1. Connect the lay-flat hose to the pump-out connection and the other end to an acceptable waste disposal.
2. Turn the pump-out switch located on the front console control panel to the **ON** position. The waste pump will now operate automatically throughout the cleaning period.



Running the pump dry for any length of time will cause damage to the pump impellers and void your warranty.



NEVER dispose of waste water in a storm drain, water way or on ground areas. Always dispose of waste in accordance with Local, State and Federal laws.

EXTRACTION PROCESS

After you have completed the previous steps, proceed with the extraction process. Place the throttle control lever to the desired speed for extraction. A float shut-off switch is located inside of the recovery tank. It will automatically shut down the unit if the tank reaches its full capacity and the indicator light on the instrument panel will turn on. If this occurs, empty the recovery tank before continuing.

SHUT DOWN AND DAILY MAINTENANCE

1. Remove as much moisture from the vacuum hoses and extraction tool as possible. This will prevent spilling of waste water when recoiling the hoses onto the reel.
2. Disconnect the vacuum hoses from the unit, leaving the vacuum port(s) open.
3. Make sure the PUMP OUT switch is in the OFF position after use.
4. Push the throttle control knob in to run at idle.
5. Allow the unit to run for 2 to 3 minutes. This will help to remove any excess moisture from the vacuum pump.

NOTE: If shutting down for the day – plug the vacuum inlet(s) and set the throttle to 50% of maximum throttle. Spray a water displacement/lubricant (i.e. WD-40) into the vacuum lubrication cup located on the lower front panel for 10 seconds. Run the unit for 1 to 2 minutes to lubricate the vacuum pump. Unplug the vacuum inlet and return the throttle control knob to run at idle.

6. Turn the RUN/OFF toggle switch to the OFF position to shut down the engine.
7. Make sure the recovery tank is completely drained manually into an approved source.

WARNING

NEVER dispose of wastewater in a storm drain, water way or on ground areas. Always dispose of waste in accordance with Local, State, and Federal laws.

8. Remove the strainer baskets and clean thoroughly before replacing.
9. Check the recovery tank filter for debris.

NOTE: To remove the vacuum inlet filter, grip the plastic hexagon section of the filter. Gripping the filter by the screen will collapse or destroy the filter. After cleaning, grease the threads on the filter and replace the filter. Tighten the filter until hand tight and then loosen ¼ turn. This will make the filter easier to remove when cleaning or replacement is required.

CAUTION

NEVER operate this unit with the filter removed, damaged or improperly installed.

At the end of the work day, rinse out the recovery tank with fresh water.

Clean the unit, tools, hoses etc., as needed. Inspect **ALL** equipment and accessories for any damage, leaks, wear, etc.

AUTOMATIC SHUT DOWNS

When the recovery tank is full, the machine will shut down and a red indicator light will illuminate on the instrument panel. If this happens, make sure the PUMP OUT switch is in the OFF position and empty the recovery tank into an approved source to resume operation.

FREEZE PROTECTION

WINTERIZING YOUR UNIT



If the waste pump is exposed to freezing weather conditions, the water inside of the pump may freeze, resulting in **SERIOUS DAMAGE to the impeller. Water freezes at 32° F and 0° C. The following is recommended to prevent this from occurring during the cold weather season:**

1. If possible, store the unit in a heated building when not in use.
2. To winterize the unit, loosen the thumb screws from the front plate of the automatic waste pump until the plate can pull away from the pump allowing the remaining water to drain out.
3. Drain the water into a container and dispose of the water into an approved waste water source.
4. Drain the pump between jobs in freezing weather conditions to prevent damaging the waste pump impeller.

SECTION THREE: SERVICE AND MAINTENANCE

MAINTENANCE CHART

DAILY, WEEKLY AND MONTHLY MAINTENANCE CHARTS..... 26

SERVICE CHART

SERVICE INTERVAL CHARTS..... 27

MAINTENANCE

ENGINE..... 29
VACUUM PUMP 30
VACUUM INLET FILTER..... 31
PRE-FILTER BOX AND RECOVERY TANK STRAINER BASKETS..... 31
VACUUM HOSES..... 31
DRIVE BELTS, PULLEYS AND HUBS 32

GENERAL SERVICE ADJUSTMENTS

VACUUM RELIEF VALVE 33

TROUBLESHOOTING

ENGINE..... 35
VACUUM PUMP 36
WASTE PUMP 36

ROUTINE MAINTENANCE CHART

DAILY MAINTENANCE

Engine	Check engine oil level. (1) Fill to proper level.
Vacuum Pump	Check vacuum pump oil level. Fill to proper level. Do not overfill. (2)
Vacuum Pump	Spray WD-40 (or Equivalent) into the lubrication cup for 10 seconds.
Vacuum Inlet Filter	Inspect filter, clean and or replace. (2)
Strainer Baskets	Empty and clean stainless steel baskets in the recovery tank and pre-filter box.
Vacuum Hoses	Rinse with fresh water. (2)
Waste Pump	Inspect and remove any debris or sediment. (2)

WEEKLY MAINTENANCE

Engine	Check air filter for damaged, dirty or loose parts.
Float Switches	Clean and inspect float switches in the recovery tank.
Visual Inspection	Check for leaks in the equipment.

MONTHLY MAINTENANCE

Engine	Inspect drive belts for wear. Replace as needed.
Engine	Inspect air intake and cooling areas. Clean if required.
Battery	Check fluid level. Fill with distilled water only. Do not overfill.
Battery Terminals	Check vehicle battery terminals. Clean as needed.
Wiring Harness	Check wiring throughout for signs of chafing or wear.
Check fasteners	Check fastener tightness on all components. Tighten as needed.

To maximize the operating life and performance, use only recommended oils, filters and greases.

- (1) Change engine oil and oil filter after first **5 to 8 hours** of operation.
- (2) Or as often as required.
- (3) Inspect after **first week** of operation, and remove any debris present. Inspect again after **2 to 4 weeks**.

SERVICE CHART

SERVICE INTERVALS – EVERY 100 HOURS

Engine	Change engine and oil filter. (1)
Vacuum Relief Valve	Check and adjust vacuum relief valve up to 13" Hg if needed.
Belts	Re-tension all belts (2)
Battery	Clean battery terminals

SERVICE INTERVALS – EVERY 200 HOURS

Engine	Clean engine air filter.
Engine	Check spark plugs and clean if necessary.

SERVICE INTERVALS – EVERY 500 HOURS

Engine	Replace inline fuel filter. (3)
Pulleys and Hubs	Check pulleys and hubs for proper torque. (4)

SERVICE INTERVALS – EVERY 1000 HOURS

Engine	Replace spark plugs
Engine	Replace air filter element.
Belts	Replace all belts.
Vacuum Pump	Drain, flush and replace oil. (5)

To maximize the operating life and performance, use only recommended oils, filters and greases.

- (1) Change engine oil and oil filter after first **5 to 8 hours** of operation.
- (2) Re-tension belts after **first 25 hours**, then every **100 hours** of operation after.
- (3) Or every 6 months, whichever comes first.
- (4) Check pulley and hub set screws after **first 50 hours** of operation, and again at **100 hours** of operation.
- (5) Every **1000 hours** or **yearly**, whichever comes first.

MAINTENANCE

This section of the operator’s manual contains the service and maintenance information for the HVE-LL unit. A planned preventative maintenance program will ensure that your HVE-LL has optimum performance, long operating life, and a minimum amount of down time.

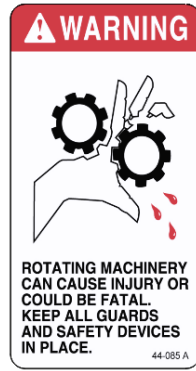
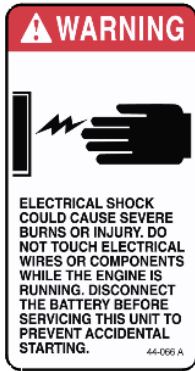

WARNING

DO NOT attempt to service this unit while it is running. High speed parts as well as high temperature components may result in severe injury, severed limbs, or fatality.

NOTE: Refer to the hour meter as a guide for coordinating a maintenance schedule.

ENGINE

Check engine oil daily. Ensure that the proper oil level is maintained. NEVER overfill.

Change the oil after the first 5 to 8 hours of operation. Thereafter, change oil filter every 50 to 100 hours of operation.

Note: Use only Kohler brand oil filters. Use of any other type of oil filter will void engine warranty.

Use high-quality oil of at least API (American Petroleum Institute) service class SG, SH, SJ or higher. **Do not use additives.** High quality 30W oil is recommended. A 10-30W synthetic blend may be used after 50 hours of operation for a new or rebuilt engine to allow the piston rings to properly seat. It is never recommended to extend oil change intervals past 100 hours

Engine Oil Capacity	1.8 L 1.9 US qts
---------------------	---------------------

Tightening Torque	
Drain Plug	13.6 N·m 1.4 kgf·m 10.0 lbf·ft

NOTE: Using lower service class oil or extending oil change intervals longer than recommended can cause engine damage.

Check the spark plugs every **200 hours** and clean if necessary. Replace spark plugs every **1000 hours**. **NEVER** sandblast spark plugs. Spark plugs should be cleaned only by scraping or wire brushing.

Clean the engine air filter element every **200 hours**. Replace the element every **1000 hours**.

NOTE: Additional engine service information can be obtained from the provided Kohler Operation and Maintenance manual. If service or repair is required, contact an authorized Kohler Service Center. They will require the serial number of the engine.

VACUUM PUMP

NOTE: Refer to the provided Vacuum Pump Operation and Service Manual for specific instructions.

Lubrication: Dri-Eaz **requires** that you use only AEON PD-XD Synthetic vacuum pump Lubricant in both sides of the vacuum pump for all operating temperatures. AEON PD-XD is formulated specifically for positive displacement vacuum pump service to provide maximum vacuum pump protection at any temperature.

NOTE: AEON PD-XD (Part # 13-004) is the only oil that Dri-Eaz puts in the vacuum pump at the factory. Adding petroleum oil to synthetic oil is **NOT** recommended.

Check the oil level **daily** on both sides to ensure they are at the proper level. Too little oil will damage and ruin the bearings and gears. Too much oil will result in overheating.

NOTE: Two drains are on your vacuum pump. Ensure that **BOTH** sides of the vacuum pump are filled to their proper level when servicing.

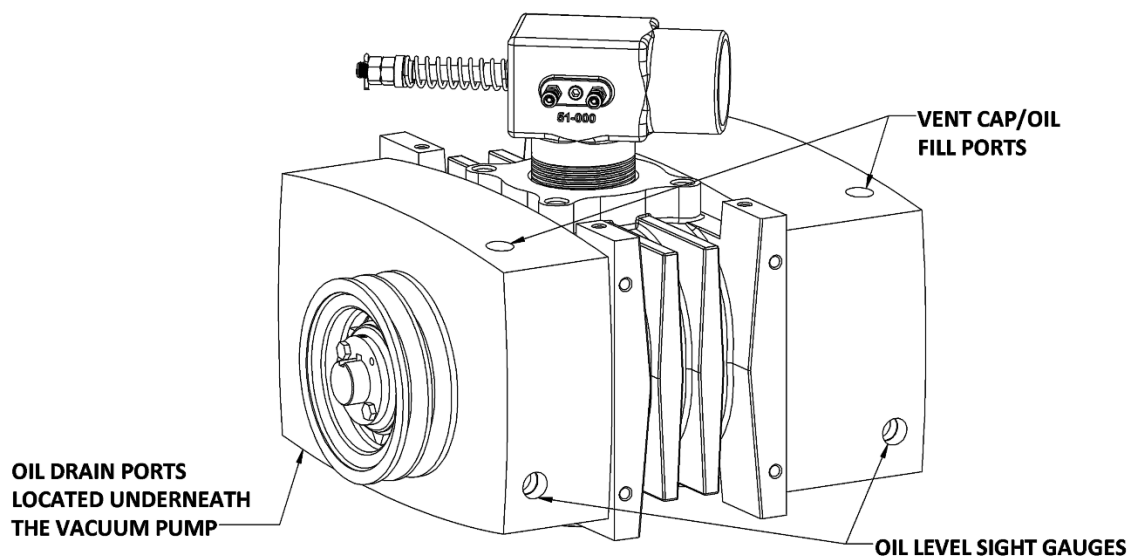

A lubrication cup has been provided at the front of the console, to prevent rust from building up inside of the vacuum pump.

Plug the vacuum ports and spray a water displacement/lubricant into the vacuum lubrication cup for 10 seconds. This procedure should be done at the end of **every working day**.

Drain, flush and replace the oil every 1000 **hours or yearly, whichever comes first**.

VACUUM INLET FILTER

The vacuum inlet filter in the recovery tank should be inspected and cleaned **daily**.



When removing the vacuum inlet filter, grip the plastic hexagon section of the filter. Grasping filter by the screen will damage or destroy the filter. Applying grease to the threads will allow easier removal of filter when cleaning or replacement is required.

PRE-FILTER BOX AND RECOVERY TANK STRAINER BASKETS

Any strainer baskets used in the system should be emptied and cleaned on a **daily** basis.

VACUUM HOSES

To ensure maximum hose life, Dri-Eaz recommends that you wash out the hoses with fresh water **daily**.

DRIVE BELTS, PULLEYS AND HUBS

Check pulley set screws and hub screws after the first **25 hours** of operation and again at **100 hours**. Re-torque these screws with a torque wrench. Follow the torque values on the following table. Check pulley set screws and hub screws every **500 hours** thereafter.

NOTE: Ensure belts are properly tensioned after checking the torque values. Use Gates EPDM belts.



Ensure that when you re-torque the screws, you use a clockwise pattern and continue until the proper torque is achieved.

TORQUE VALUES		
Component	Inch/lbs	Foot/lbs
Vacuum Pump Hub #38-032	180	15

BELT REPLACEMENT PROCEDURES FOR THE HVE-LL

1. Disconnect the negative battery terminal.
2. Remove the hose from the recovery tank to the vacuum pump.
3. Remove hoods.
4. Remove top panel.
5. Remove left and right hand belt guards.
6. Remove the clamp between the blower and the silencer.
7. Loosen all 4 blower mounting nuts.
8. Slide the blower back (away from engine).
9. Lower front two nuts located under the front of the blower mounting plate approximately 1/2".
10. Tip the back of the blower up.
11. Remove all belts. Install new belts.
12. Reverse procedures to install new belts, lower the back of the blower and slide the blower forward, raising the front two nuts to the same height as the rear nuts.
13. Tighten all nuts to tension belts, checking for proper tension and alignment. Use a belt gauge to check tension. Set deflection to 1/8"; 10 to 12 lbs. of tension.
14. Check pulleys for alignment using a straight edge (example: 1/2" key stock bar). Make sure pulley flange touches on 2 places on each pulley (4 total).

(Estimated time 2 hours)

GENERAL SERVICE ADJUSTMENTS

WARNING

DO NOT attempt to service this unit while it is running. High speed parts as well as high temperature components may result in severe injury, severed limbs, or fatality.

VACUUM RELIEF VALVE

With the unit running at high speed, block off the airflow at the vacuum inlet port and read the vacuum gauge. If adjustment is required, shut the unit down and adjust the locking nut tension on the vacuum relief valve. Re-start the unit and read the vacuum gauge. Repeat this process until the vacuum relief valve opens at 13” Hg. Always ensure the lock nut is retightened and the cotter pin is replaced.

WARNING

To reduce the risk of injury: NEVER obstruct the vacuum port with your hand or other body part. Keep hair, loose clothing and all body parts away from vacuum port openings while unit is in operation.

TROUBLESHOOTING

WARNING

DO NOT attempt to service this unit while it is running. High-speed parts as well as high temperature components may result in severe injury, severed limbs or fatality.

This section of the operator's manual describes how to look for and repair malfunctions, which may occur. Accurate troubleshooting is based on a thorough and complete understanding of the **ENGINE**, **VACUUM**, **SAFETY** and **WIRING** systems featured in this unit.

If there are malfunctions occurring on this unit which you do not understand, refer back to the **OPERATION** section of this manual and review **SYSTEM**.

ENGINE TROUBLESHOOTING**ENGINE WILL NOT START (STARTER DOES NOT TURN OVER)**

PROBABLE CAUSE	SOLUTION
Main circuit breaker on the control panel has been tripped.	After inspecting the unit to determine the cause of the tripped breaker, press the reset button.
Loose or corroded battery connections.	Clean, tighten or replace the battery terminals.
Dead battery.	Recharge or replace battery
Defective ignition button.	Test ignition button for power going into the circuit. If there is power going in, but none coming out, replace the button.
Defective starter motor.	Test the starter motor. Replace if necessary.
Vacuum pump seized.	Refer to the vacuum pump manufacturer service and repair manual.

STARTER TURNS OVER BUT ENGINE WILL NOT START

PROBABLE CAUSE	SOLUTION
Recovery tank is full.	Empty the recovery tank.
Defective fuel pump.	Replace the fuel pump.
Loose or broken wires leading to the recovery tank float switch.	Repair or replace any broken electrical connections.
Defective float switch inside recovery tank.	Check switch for proper operation. Replace if necessary.
Oil pressure switch (located on engine), fuel shut-off solenoid (located on engine).	Test these components. If any are defective, replace. Consult the Kohler Engine Operation and Maintenance Manual.
Engine is malfunctioning.	Refer to Kohler Engine Operation and Maintenance Manual.

ENGINE STOPS RUNNING DURING NORMAL OPERATION

PROBABLE CAUSE	SOLUTION
Engine is out of gasoline.	Check the fuel tank.
Recovery tank is full.	Empty recovery tank.
Main circuit breaker on the control panel has been tripped.	After inspecting the unit to determine the cause of the tripped breaker, press the reset button.
Defective fuel pump.	Replace fuel pump.
Defective float switch inside recovery tank.	Check switch for proper operation. Replace if necessary.
Oil pressure switch on engine has shut down due to insufficient oil pressure.	Refer to the Kohler Engine Operation and Maintenance Manual. DO NOT restart the engine until the cause is determined and corrected.
No ignition in the engine or the engine is malfunctioning.	Refer to the Kohler Engine Operation and Maintenance Manual.

VACUUM PUMP TROUBLESHOOTING**LOSS OF VACUUM** (while cleaning, engine RPM is normal but vacuum is lower than expected)

PROBABLE CAUSE	SOLUTION
Vacuum gauge is giving an improper reading.	Examine the tubing between the vacuum relief valve and the vacuum gauge and remove any blockage.
Vacuum hose(s) is damaged, causing a suction leak.	Inspect hose(s), repair or replace.
Waste tank gaskets not sealing properly, not positioned properly.	Inspect the gasket. Repair seal or replace Re-position lid(s).
Plugged vacuum hose or vacuum plumbing between vacuum inlet and strainer basket.	Unplug vacuum hose or inlet plumbing.
Waste tank filter or strainer basket is plugged.	Clean or replace filter. Clean strainer basket.
Loose vacuum pump drive belts.	Tighten the drive belts.
Waste tank drain valve is damaged or left open, causing a vacuum leak.	Drain the waste tank. Close drain valve, if open. Replace valve if defective.
Vacuum relief valve requires adjustment or has a vacuum leak due to damaged diaphragm.	Re-adjust the vacuum relief valve. If the vacuum does not increase, remove and inspect the relief valve diaphragm. If damaged, replace.
Vacuum pump is worn out.	Replace the vacuum pump.

WASTE PUMP TROUBLESHOOTING**WASTE PUMP IS MALFUNCTIONING**

PROBABLE CAUSE	SOLUTION
Defective waste pump float switch.	Replace float switch.
Broken impeller in pump.	Replace impeller.
Pump out circuit breaker on instrument panel has tripped.	After inspecting waste pump to determine the cause of the overloaded circuit, press reset button.
Ball valve closed.	Open valve.
Weak battery.	Charge or replace battery. Check charging station.

SECTION FOUR: PARTS AND ACCESSORIES

ILLUSTRATED PARTS LISTING

CONSOLE ASSEMBLY	38
RECOVERY TANK	41
FRAME AND ENCLOSURES	42
INSTRUMENT PANEL	43
ENGINE	45
VACUUM PUMP	47
WASTE PUMP ASSEMBLY	49
BELT GUARD BLOWER.....	50
PRE-FILTER BOX.....	51
EXTENDED FUEL LINE	52
KIT COMPONENTS.....	53
DECALS	55
ELECTRICAL	
ELECTRICAL DIAGRAM	56

70-300HVE, CONSOLE, DRI-EAZ HVE-LL (FIG. 1 OF 2)

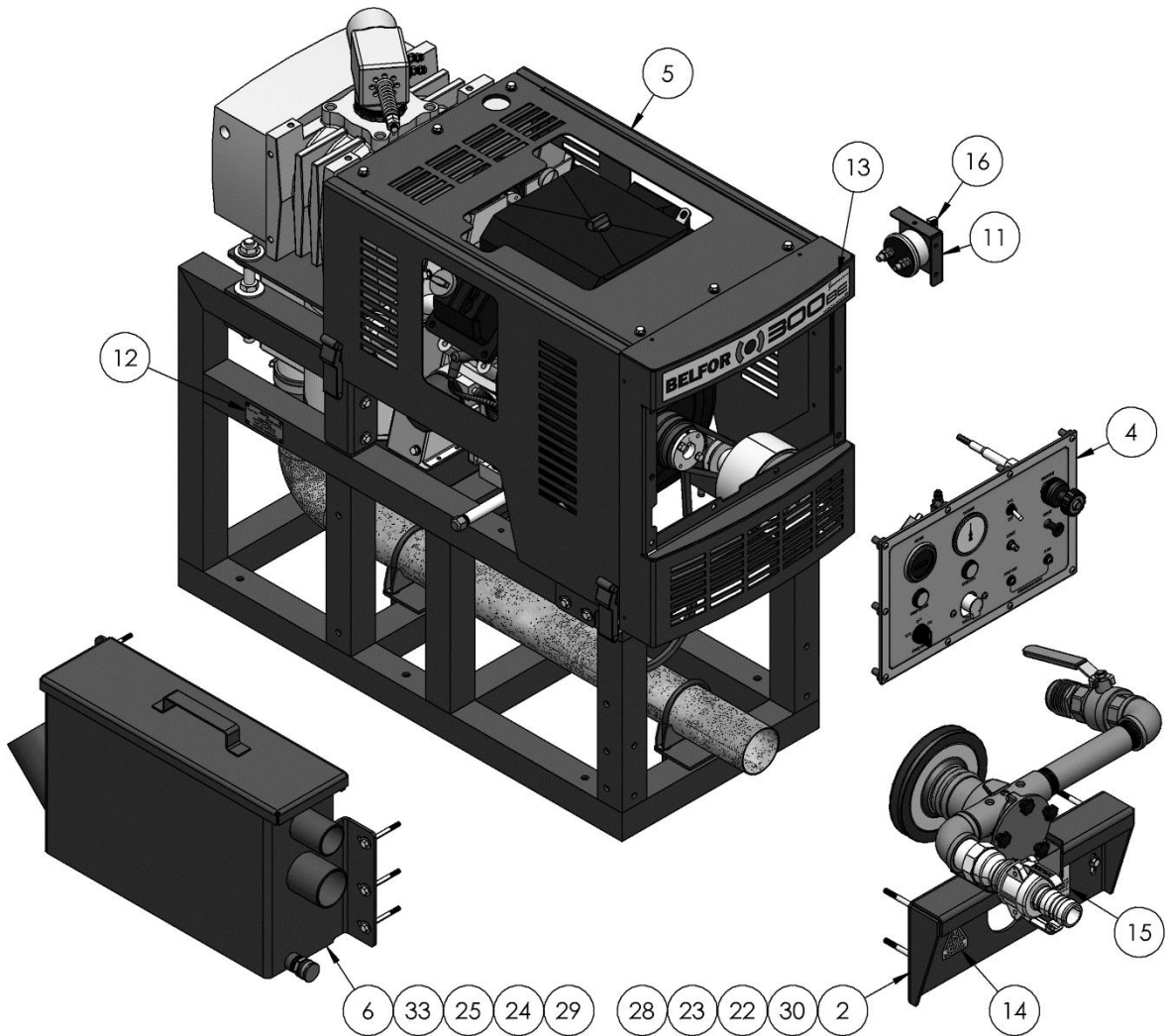

70-300HVE, CONSOLE, DRI-EAZ HVE-LL (FIG. 2 OF 2)

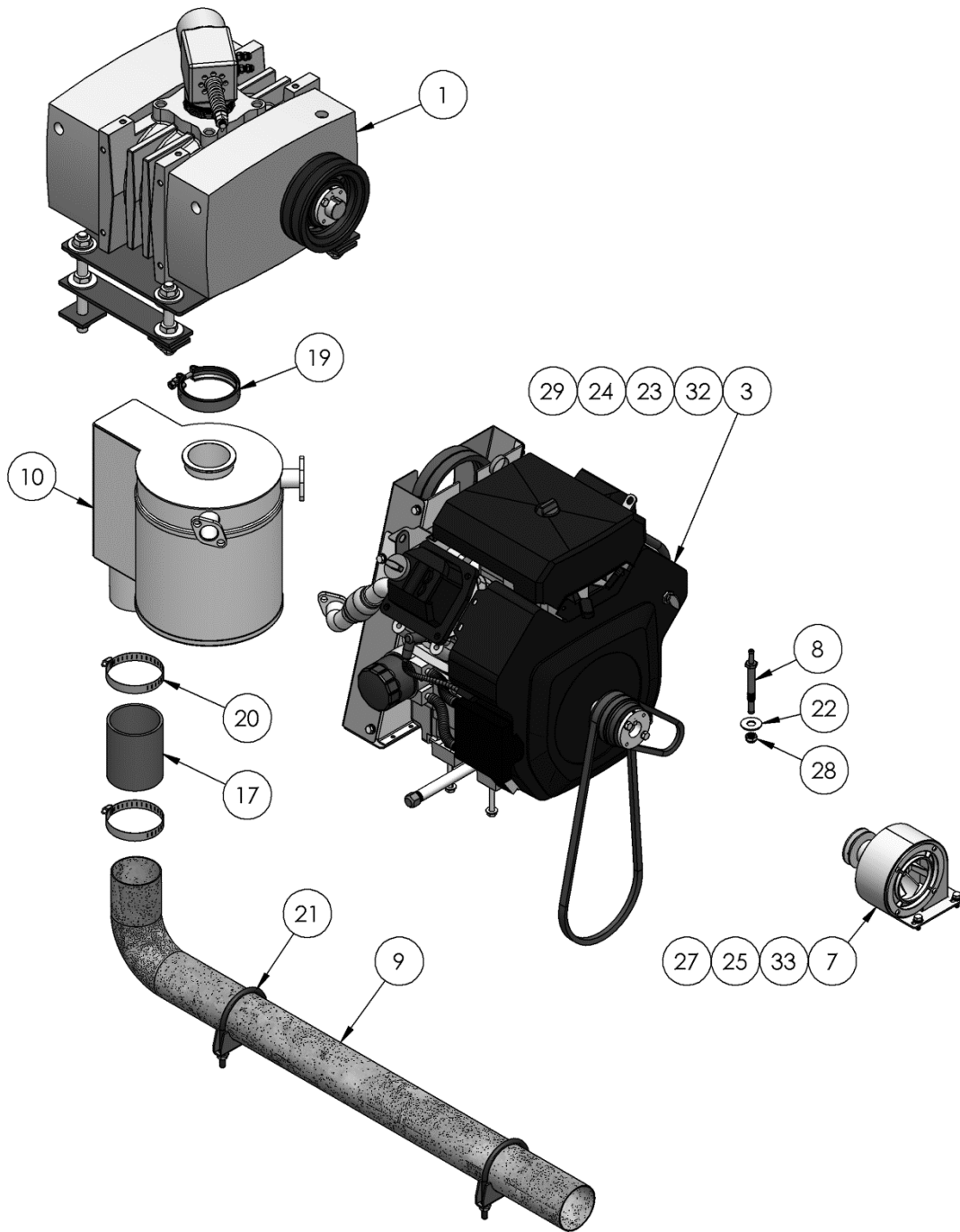

70-300HVE, CONSOLE, DRI-EAZ HVE-LL - BOM TABLE

5	33	10-028	SCREW, MACH 1/4-20 X 2-3/4 HXHD
4	32	10-032	SCREW, MACH 1/4-20 X 3/4 HXHD
4	31	10-145	SCREW, MACH 5/16-18 X 4 HXHD
4	30	10-174	SCREW, MACH 5/16-18 X 3 HXHD
5	29	11-004	NUT, 1/4-20 ZINC
8	28	11-005	NUT, 5/16-18 ZINC
1	27	11-088	NUT, 7/16-20 THIN NYLOK ZPS
4	26	12-011	WASHER, FLAT #12 SAE
10	25	12-012	WASHER, FLAT 1/4 USS
9	24	12-015	LKWSR, 1/4 ZINC
8	23	12-016	LKWSR, 5/16 ZINC
16	22	12-017	WASHER, FLAT 5/16 SAE ZINC
1	21	12-021	WASHER, FLAT, 7/16 ZINC
2	20	14-002	CLAMP, MUFFLER 3 IN
2	19	14-024	CLAMP, HOSE #48 SS
1	18	14-046	CLAMP, 2-12 V-BAND
1	17	16-108	HOSE, 3.0 IN ID X 3FT SILICONE 550F
1	16	29-079	SWITCH, BATTERY DISCONNECT
1	15	44-067	DECAL,WARNING READ MANUAL
1	14	44-187	DECAL, CO DANGER TRIANGLE
1	13	44-273	DECAL, PRODUCT 300BE
1	12	44-274	PLATE, SERIAL 300BE
1	11	58-889	PANEL, SWITCH MOUNT
1	10	61-1326	ASSEMBLY, SILENCER 370 SE
1	9	61-1327	WELDMENT, EXHAUST TUBE
1	8	66-359	FITTING, 1/4 X 5/16 FUEL LINE MANIFOLD
1	7	69-184	ASSY, BELT GUARD BLOWER
1	6	69-714-026	ASSY, PREFILTER BOX
1	5	69-794	ASSY, FRAME AND ENCLOSURES
1	4	69-796	ASSY, CONTROL PANEL
1	3	69-797	ASSY, ENGINE
1	2	69-801	ASSY, WASTE PUMP OUT
1	1	69-804	ASSY, VACUUM PUMP
QTY	ITEM	PART NO.	DESCRIPTION

69-798, ASSEMBLY, RECOVERY TANK

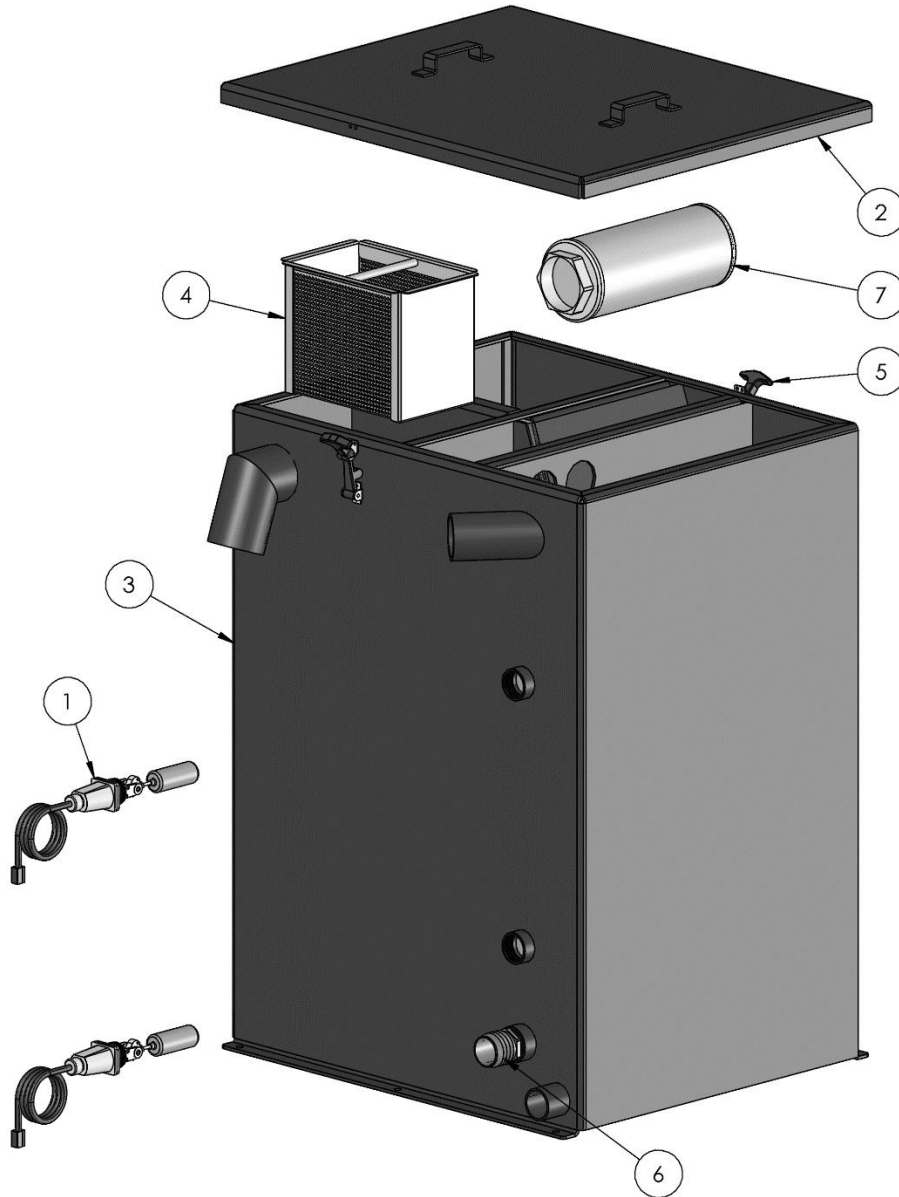

1	7	20-021	STRAINER, FILTER 3" 100 MESH
1	6	21-094	FTTG, 1-1/2 P X 2H DRAIN
2	5	40-003	LATCH, PRE-FILTER BOX
1	4	61-002	WELDMENT, STRAINER BASKET
1	3	61-1328	WELDMENT, WASTE TANK
1	2	69-806	ASSY, WASTE TANK LID
2	1	69-000	FLOAT SWITCH
QTY	ITEM	PART NO.	DESCRIPTION

69-646, ASSEMBLY, FRAME AND ENCLOSURES

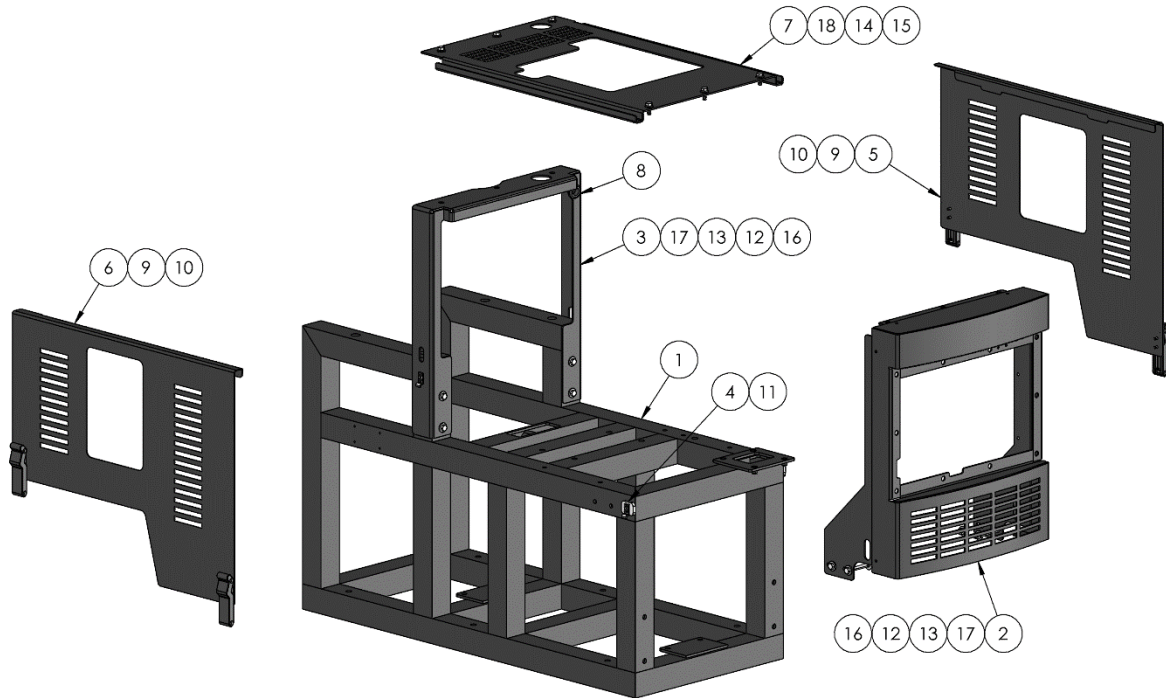

6	18	10-020	SCREW, MACH 1/4-20 X 3/4 HXHD SS
8	17	10-028	SCREW, MACH 1/4-20 X 2-3/4 HXHD
8	16	11-004	NUT, 1/4-20 ZINC
6	15	12-002	WASHER, FLAT 1/4 SS ANC
6	14	12-003	LKWSR, 1/4 IN SS
16	13	12-012	WASHER, FLAT 1/4 USS
8	12	12-015	LKWSR, 1/4 ZINC
4	11	14-085	RIVET, 5/32 X .312 HD .251-.375 GRIP SS
12	10	14-086	RIVET, 5/32 X .312 HD .062-.125 GRIP SS
4	9	40-034	LATCH, DRAW SS CONCEALED MOUNT
1	8	41-096	GROMMET, 1-1/8 OD X 5/8 ID X 1/8 PANEL
1	7	58-692	PANEL, TOP
1	6	58-693	PANEL, LS
1	5	58-694	PANEL, RS
2	4	60-2134	PLATE, KEEPER MOUNT
1	3	61-1076	WELDMENT, REAR BRACE
1	2	61-1083	WELDMENT, FRONT BEZEL
1	1	61-1325	WELDMENT, FRAME
QTY	ITEM	PART NO.	DESCRIPTION

69-796, ASSEMBLY, INSTRUMENT PANEL

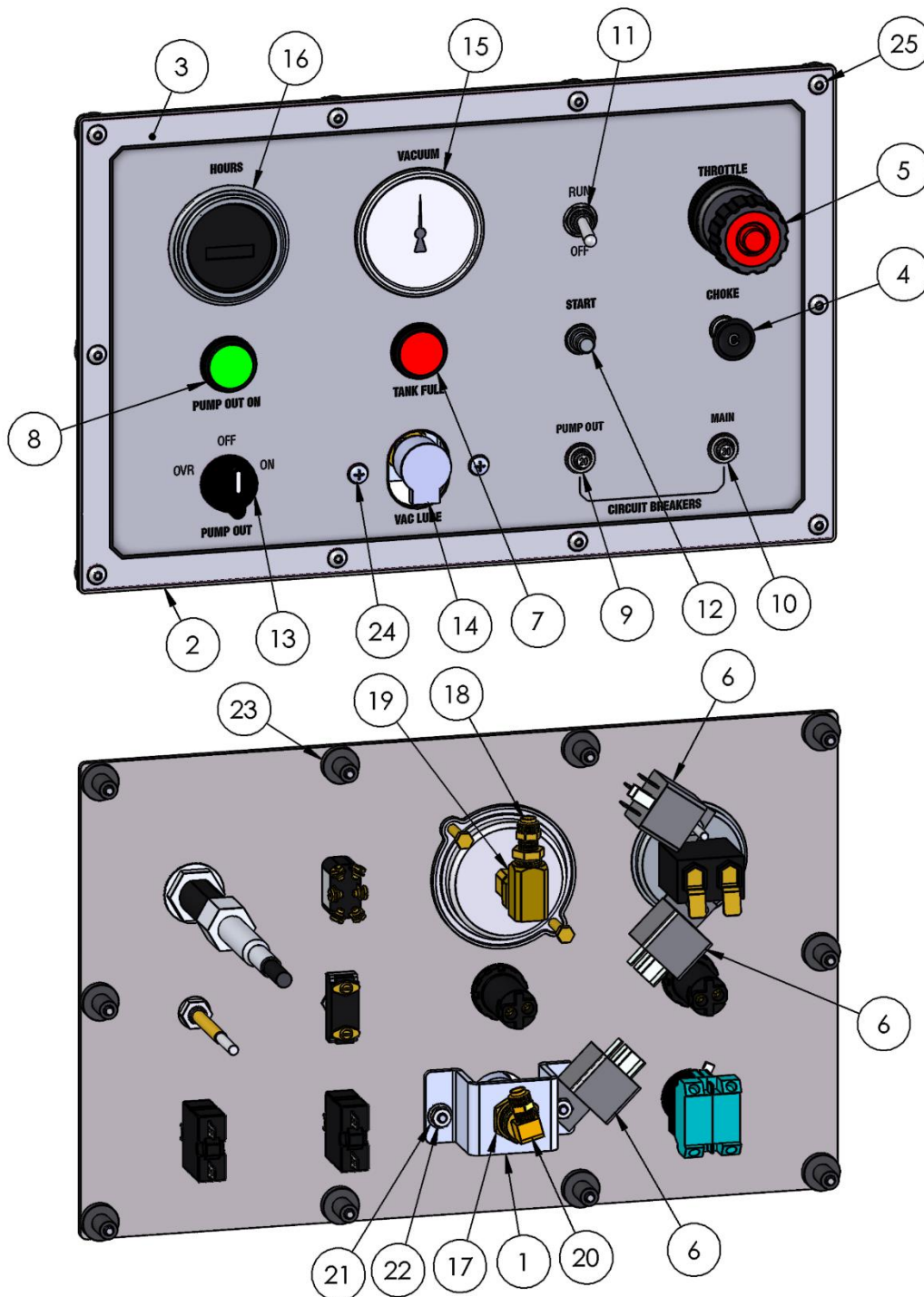

69-796, ASSEMBLY, INSTRUMENT PANEL – BOM TABLE

10	25	10-016	SCREW, MACHINE 10-32 X 1 SOCHD SS
2	24	10-150	SCREW - 10-32 X .500 PHP ZP
10	23	11-002	NUT, WELL G 10-32
2	22	11-096	NUT, 10-32 KEPS ZP
2	21	12-091	WASHER, FLAT #10 SAE ZP
1	20	21-011	ELL, 1/8 NPT X 1/4 POLY BRASS
1	19	21-037	ELL, 1/4 IN. BRASS
1	18	21-433	CONN, 1/4 P X 1/4 POLY
1	17	21-579	FTTG, BULKHEAD 1/8 BRASS
1	16	26-033	HOURMETER, HOBBS CHROME BEZEL
1	15	26-044	GAUGE, VACUUM 2.5 IN 0-30 IN/HG
1	14	28-000	CUP, OILFILL, 1/8 NPT
1	13	29-020	SWITCH, ROTARY NON-ILLUMINATED
1	12	29-037	SWITCH, PUSH BUTTON SELECTA
1	11	29-078	SWITCH, TOGGLE DPDT
1	10	30-007	BREAKER, 30 AMP
1	9	30-008	BREAKER, 20 AMP
1	8	30-136	LIGHT, 22MM GREEN
1	7	30-137	LIGHT, 22MM RED
3	6	34-010	RELAY, ENG.SHTDWN12V20/30AMP
1	5	40-031	CABLE, THROTTLE
1	4	40-032	CABLE, CHOKE
1	3	44-271	DECAL, INSTRUMENT PANEL
1	2	58-880	PANEL, INSTRUMENT
1	1	58-885	BRACKET, VAC LUBE
QTY	ITEM	PART NO.	DESCRIPTION

69-797, ASSEMBLY, ENGINE

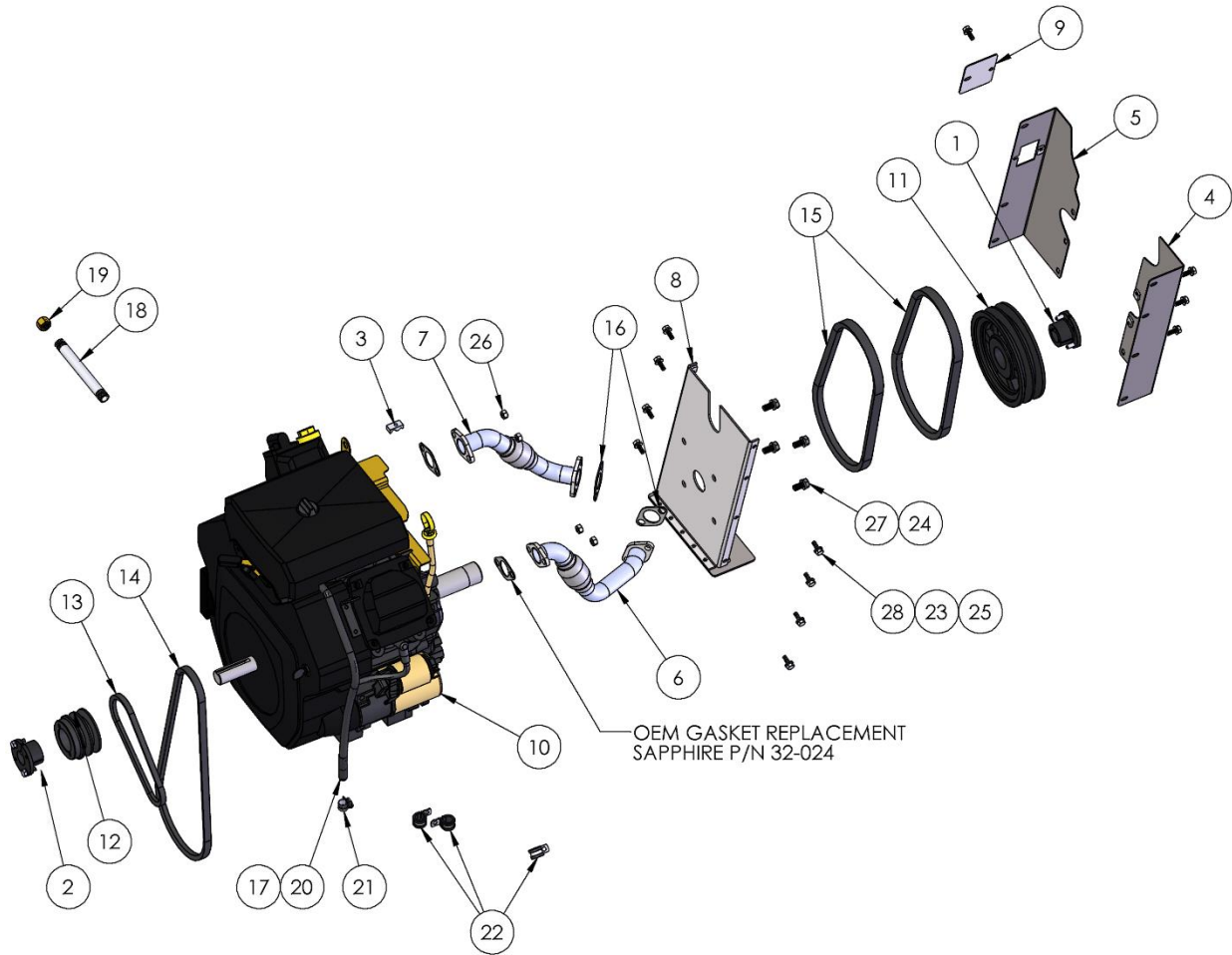

SECTION FOUR – PARTS AND ACCESSORIES

69-797, ASSEMBLY, ENGINE – BOM TABLE

12	28	10-025	SCREW, MACH 1/4-20 X 3/4 HXHD GRD5
4	27	10-070	BOLT - .375-16 X .75 HH ZP
4	26	11-005	NUT, 5/16-18 ZINC
12	25	12-011	WASHER, FLAT #12 SAE
4	24	12-014	LKWSR, 3/8 ZINC
12	23	12-015	LKWSR, 1/4 ZINC
3	22	14-005	CLAMP,WIRE CUSHION 5/8 ID X 1/4 BOLT
1	21	14-007	CLAMP, HOSE #4
2.33 FT	20	16-104	HOSE, FUEL 1/4 30R9 FUEL INJECTION
1	19	21-326	CAP, 3/8 NPT BRASS
1	18	21-329	NIPPLE, 3-8 NPT X 6 SS
24 IN	17	32-027	LOOM, HI HEAT .500 DIA. BLACK
2	16	36-016	GASKET, EXHAUST
2	15	37-060	BELT, BX32 GATES EPDM
1	14	37-064	BELT, GATES AX38 MATCH
1	13	37-093	BELT, 3L180
1	12	38-048	PULLEY, BROWNING 2AK34H
1	11	38-050	SHEAVE, BROWNING 2BK70H
1	10	45-040	ENGINE, KOHLER 20 HP
1	9	58-397	PLATE, BELT INSPECTION
1	8	61-452	WELDMENT, BELT GUARD, 370 SS
1	7	61-468	ASSY, EXHAUST TUBE LS 370SS
1	6	61-469	ASSY, EXHAUST TUBE RS 370SS
1	5	61-834	WELDMENT, BELT GUARD LS
1	4	61-835	WELDMENT, BELT GUARD RS
1	3	66-122	RETAINER, CABLE
1	2	66-542	HUB, H X 1 W/SET SCREW
1	1	66-543	HUB, H X 1-1/8 W/SET SCREW
QTY	ITEM	PART NO.	DESCRIPTION

69-804, ASSEMBLY, VACUUM PUMP

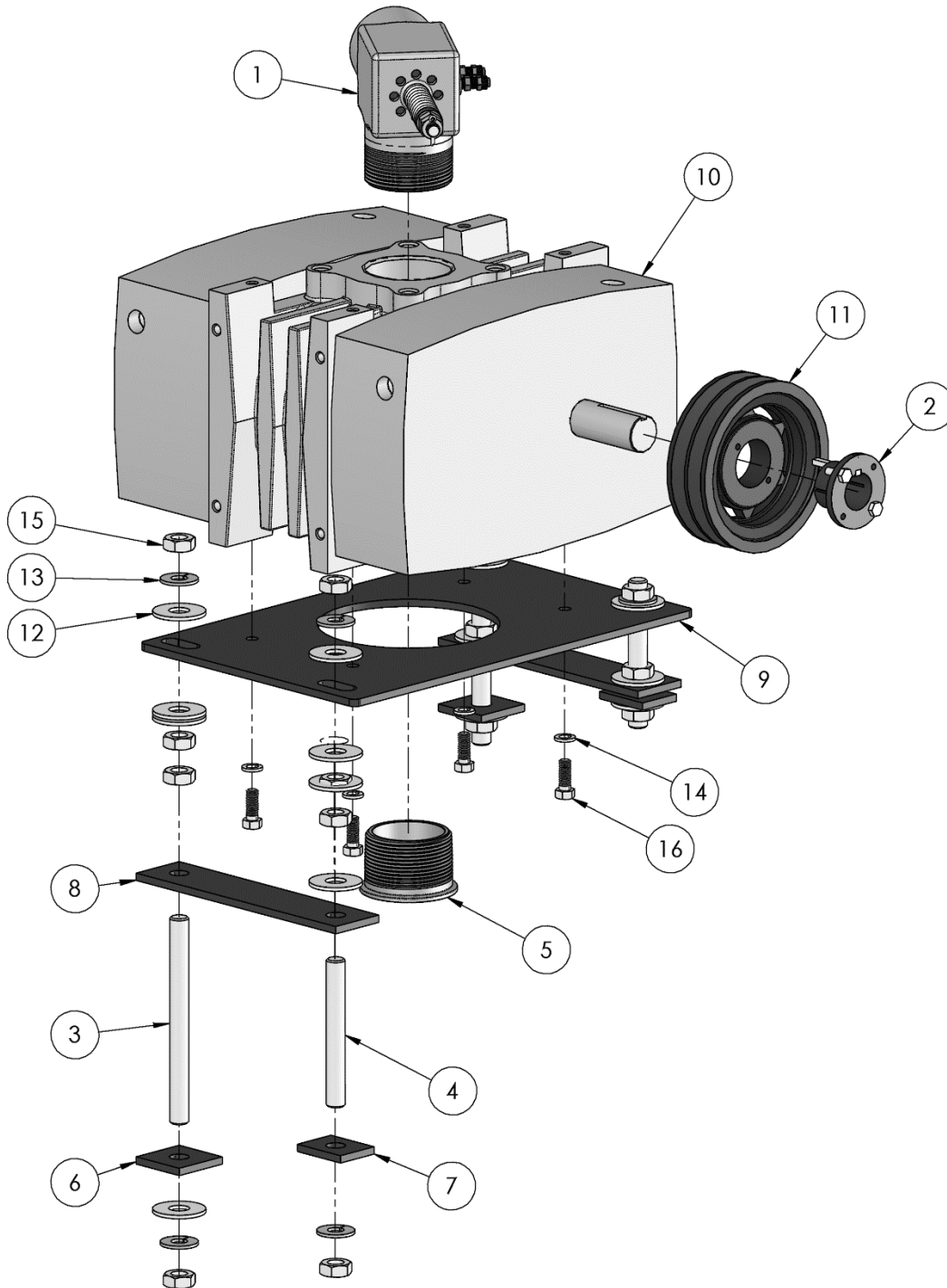

SECTION FOUR – PARTS AND ACCESSORIES

69-804, ASSEMBLY, VACUUM PUMP – BOM TABLE

4	16	10-029	SCREW, MACH 3/8-16 X 1 HXHD
16	15	11-062	NUT, 5/8-18 JAM
4	14	12-014	LKWSR, 3/8 ZINC
8	13	12-039	WASHER, LOCK, .625
16	12	12-040	WASHER, FLAT .625 USS
1	11	38-117	PULLEY, 2BK60H
1	10	46-055	VACUUM PUMP, GD TI-406, PN GYCMJCA0188
1	9	58-377-026	PLT, VACUUM PUMP MOUNTING
2	8	58-378-026	PLATE, BLOWER MOUNTING TOP
2	7	58-379-026	PLATE,BLOWER MOUNTING MIDDLE
2	6	58-380-026	PLATE, BLOWER MOUNTING BOTTOM
1	5	66-208	FLANGE, 370 BLOWER OUTLET
2	4	66-227-02	THREADED ROD, 5/8-18 X 5.0 IN
2	3	66-227-04	THREADED ROD, 5/8-18 X 7.0 IN
1	2	66-544	HUB, H X 1-1/4 W/SET SCREW
1	1	69-432	ASSEMBLY, VACUUM BRAKE, 3L & 4M
QTY	ITEM	PART NO.	DESCRIPTION

69-801, ASSEMBLY, WASTE PUMP OUT

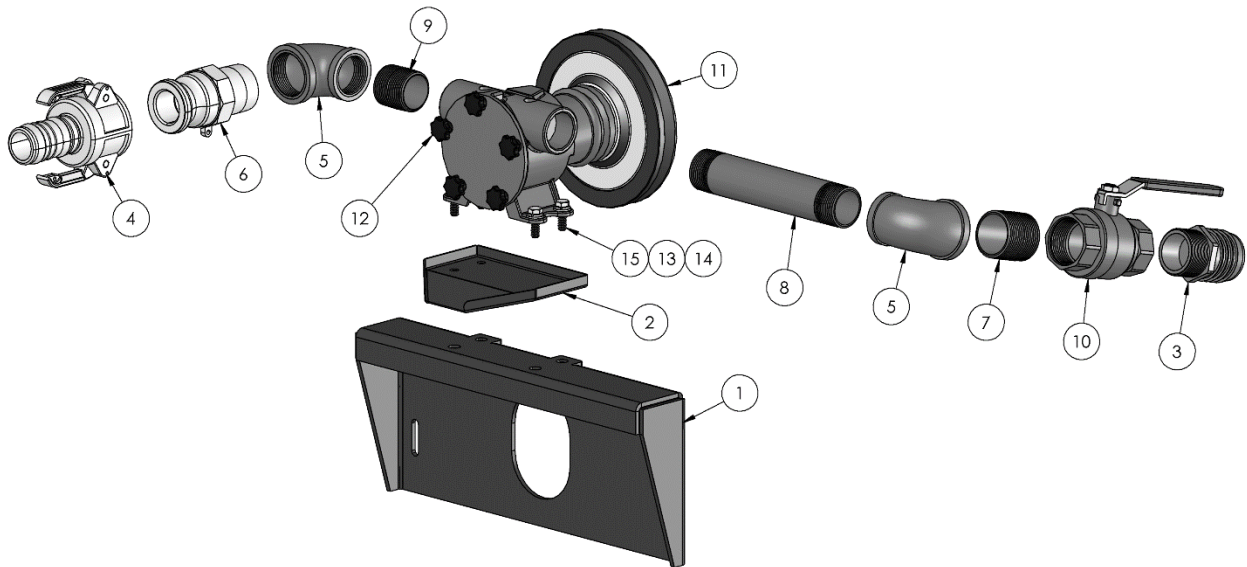

4	15	10-106	BOLT, 5/16-18 X 1 HHCS Z5
4	14	12-016	LKWSR, 5/16 ZINC
4	13	12-017	WASHER, FLAT 5/16 SAE ZINC
5	12	10-368	SCREW, THUMB 1/4-20 X 9/16 NYLON KNOB
1	11	46-054	PUMP, JABSCO
1	10	23-050	VALVE, BALL 1-1/2 NPT BRASS
1	9	21-510	NIPPLE, CLOSE 1-1/4 NPT BRASS
1	8	21-496	NIPPLE, 1-1/4 NPT X 8 BRASS
1	7	21-392	NIPPLE, 1-1/2 NPT CLOSE BRASS
1	6	21-356	ADAPTER, 1-1/2 NPT X 1-1/2 CAM & GROOVE
2	5	21-339	ELBOW, FEMALE 1.50 NPT REDUCE TO 1.25 NPT BRASS
1	4	21-307	COUPLING,ALUM LL 1 1/2 2 1/8X
1	3	21-094	FTG, 1-1/2 P X 2H DRAIN
1	2	61-1351	WELDMENT, PUMP DRAIN
1	1	61-1332	WELDMENT, PUMP MTG BRACKET
QTY	ITEM	PART NO.	DESCRIPTION

69-184, ASSEMBLY, BELT GUARD BLOWER

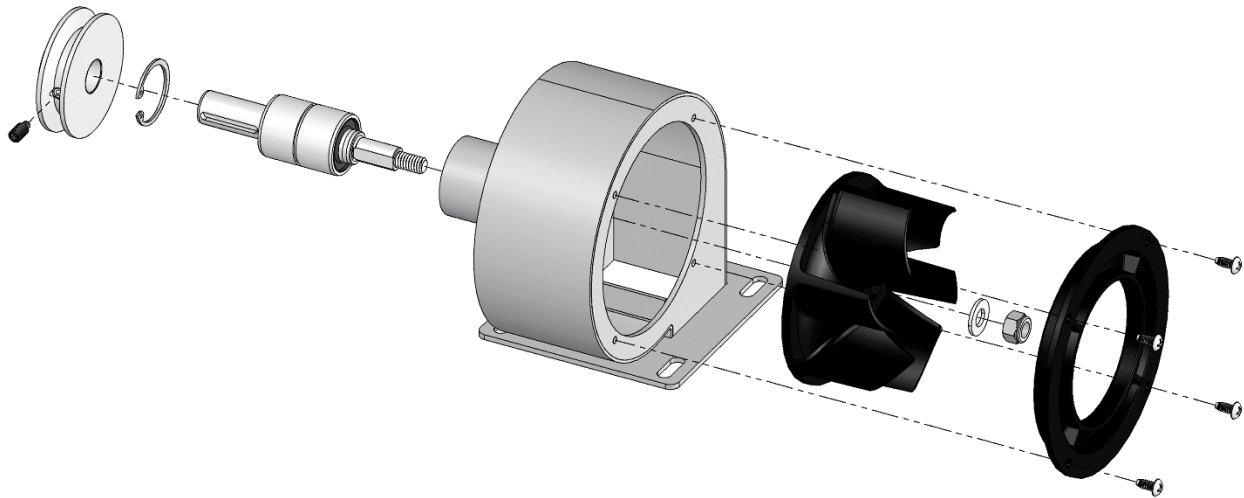

1	10	15-027	SNAP RING, 1.187 INTERNAL
1	9	39-075	BEARING, BELT GUARD BLOWER
1	8	10-219	SCREW, FULL DOG SET 1/4-20 X 1/2 BLK
1	7	11-029	NUT, 5/16-18 NYLOCK
1	6	12-017	WASHER, FLAT 5/16 SAE ZINC
1	5	51-043	COVER, AIR WHEEL
1	4	51-042	AIR WHEEL, MOLDED
4	3	10-146	SCREW, 8-32 X .375 PHP F THREAD CUTTING ZP
1	2	66-215	PULLEY, 3L BELT X 2.340 OD
1	1	61-465	WELDMENT, BLOWER HOUSING
QTY	ITEM	PART NO.	DESCRIPTION

69-714-026, ASSEMBLY, PREFILTER BOX

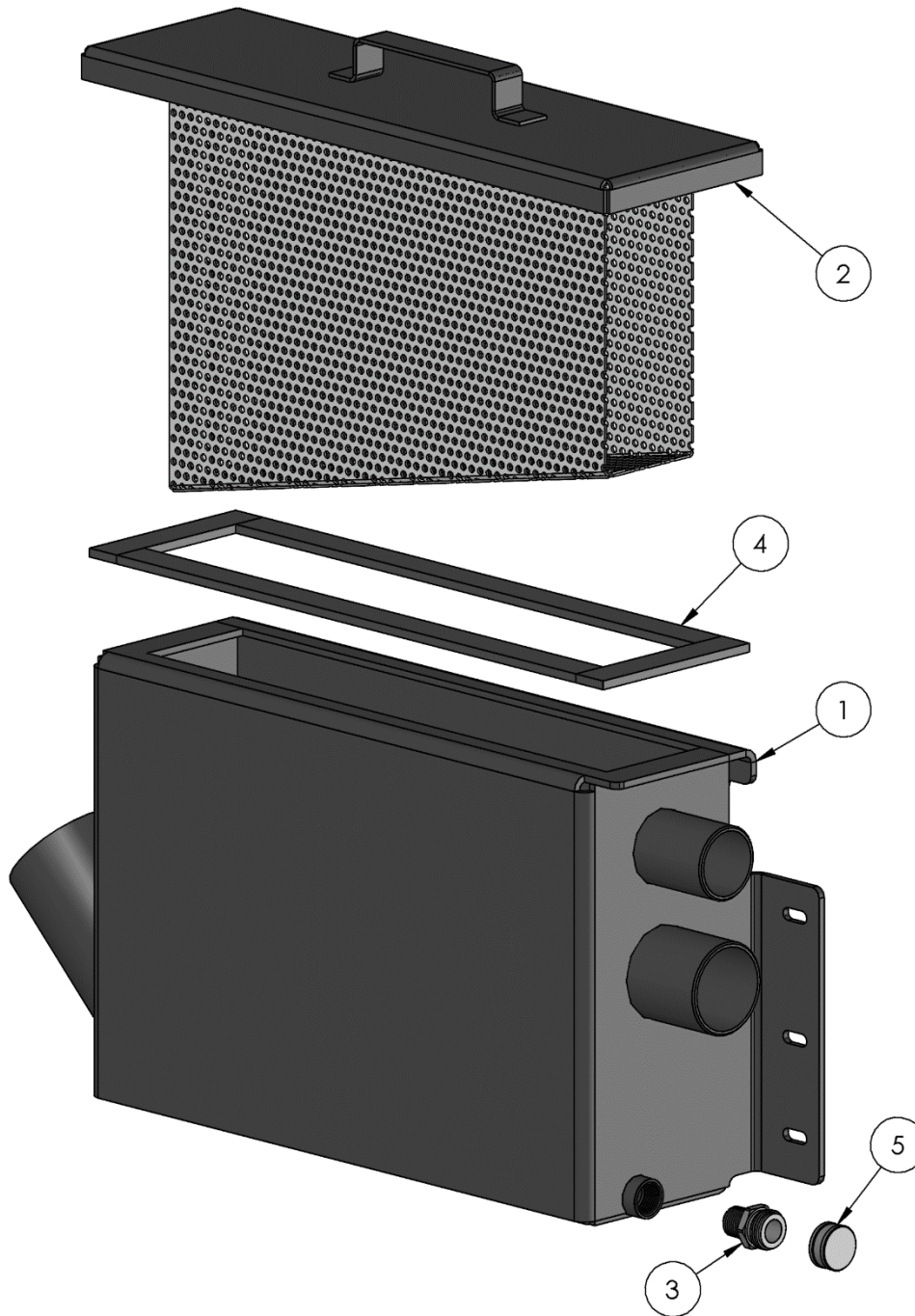

1	5	21-071	CAP, GARDEN HOSE 3/4 BRASS
44.52	4	41-018	GASKET, SPONGE 1 IN X 45 FT
1	3	21-398	FTTG, GRDN HOSE 1/2 P X 3/4 H
1	2	61-1215	WELDMENT, FILTER BOX LID
1	1	61-1214	WELDMENT, PREFILTER BOX
QTY	ITEM	PART NO.	DESCRIPTION

68-408, KIT, EXTENDED FUEL LINE

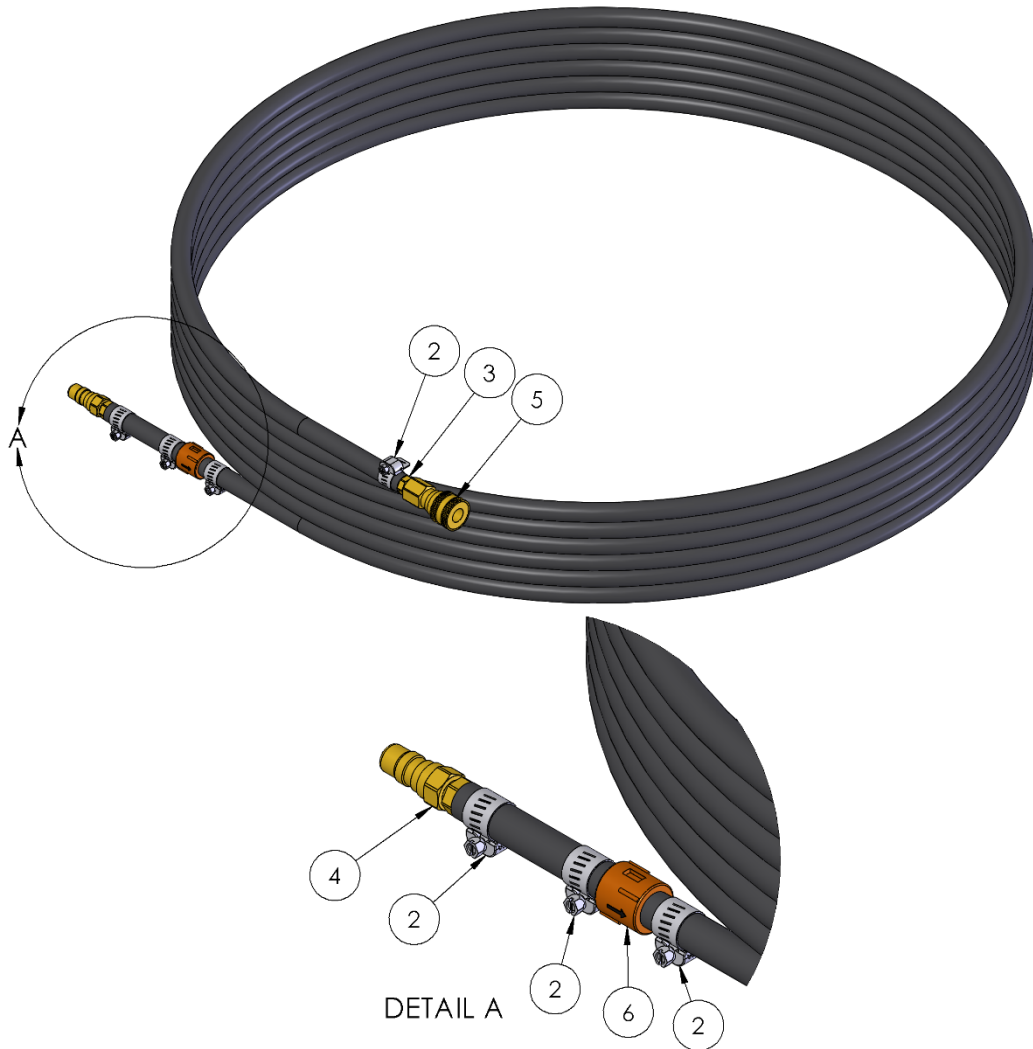

1	6	23-087	CHECK VALVE, FUEL
1	5	25-010	DSC, 1/8F X 1/8FP BR
1	4	25-009	DSC, 1/8MX 1/8FP BR
2	3	21-007	FTG, BRB 1/8 P X 5/16 H BR
4	2	14-007	CLAMP, HOSE #4
1	1	16-103	HOSE, FUEL 5/16 30R9 FUEL INJECTION
QTY	ITEM	PART NO.	DESCRIPTION

KIT COMPONENTS

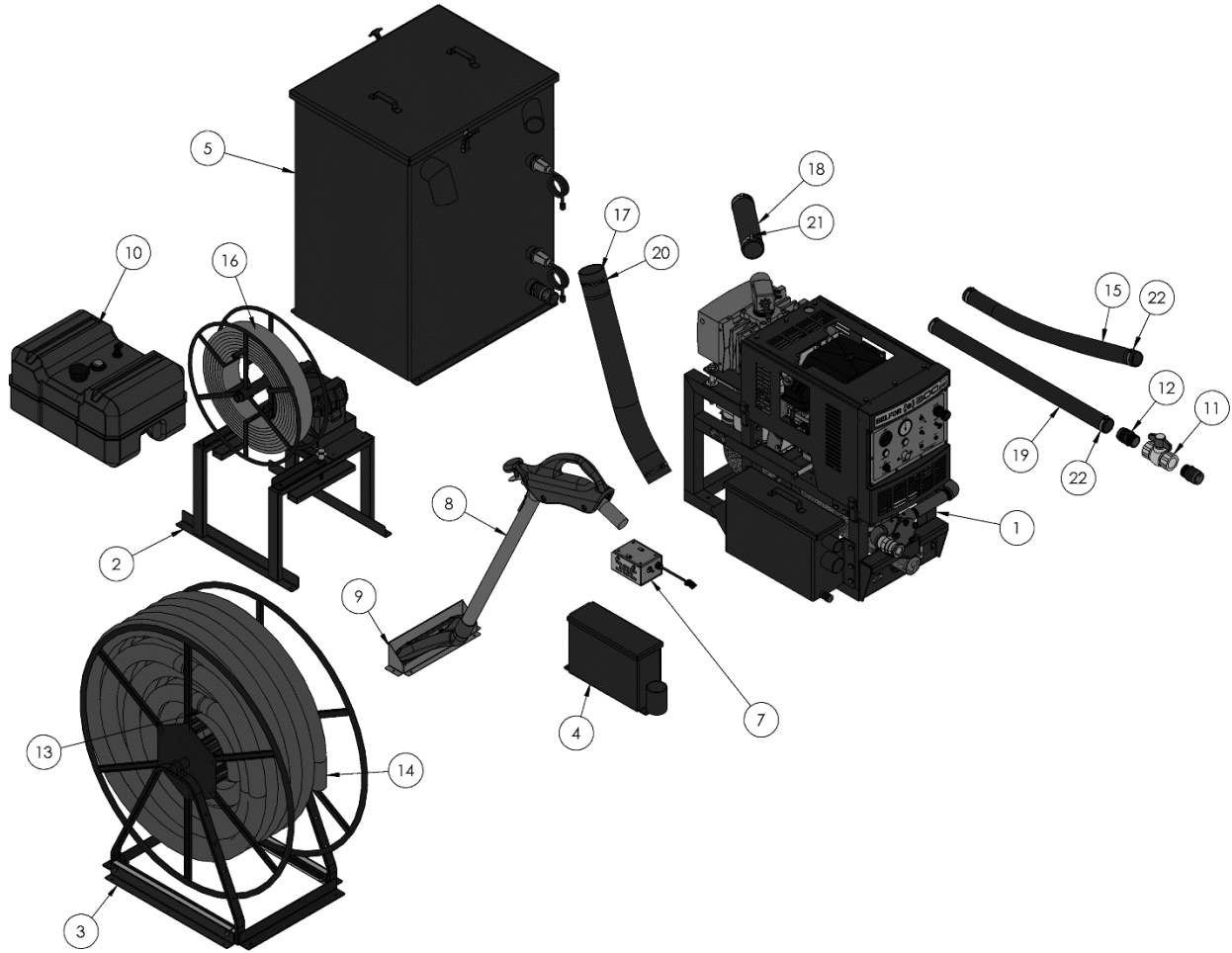

SECTION FOUR – PARTS AND ACCESSORIES

KIT COMPONENTS – BOM TABLE

4	22	14-010	CLAMP, HOSE #32
2	21	14-024	CLAMP, HOSE #48 SS
2	20	14-050	CLAMP, HOSE 4 1/2 TO 2 1/2 HD SS
1	19	16-009	HOSE, INT VAC 2 IN.
1	18	16-011	HOSE, INT VAC 2.875
1	17	16-014	HOSE, INT VAC 3.50 IN
4	16	16-082	HOSE, 1.50 ID X 50FT DISCHARGE GRAY FABRIC PCV
1	15	17-413	HOSE, INT VAC 2 IN X 5FT
4	14	18-003	HOSE, VAC 2 IN FLEX SUPER TM
3	13	21-003	FTG, BRB 2 IN H BS PVC
2	12	21-094	FTG, 1-1/2 P X 2H DRAIN
1	11	23-022	VLV, BALL 1-1/2 FP PVC DUMP
1	10	50-028	TANK, FUEL 12 GAL LOW PROF W/GAUGE
1	9	61-1657	WELDMENT, WAND HEAD BRKT
1	8	67-059	WAND, EXTRACTOR
1	7	68-030	ASSY,FUEL PUMP HOUSING
1	6	68-194	KIT, FUEL HOSE & FILTER
1	5	69-798	ASSY, WASTE TANK
1	4	69-809	ASSY, STORAGE BOX
1	3	69-810	ASSY, VACUUM HOSE REEL
1	2	69-811	ASSY, WATER HOSE REEL
1	1	70-300BE	CONSOLE, SAPPHIRE 300 BE
QTY	ITEM	PART NO.	DESCRIPTION

DECALS

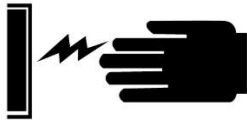

**ELECTRICAL SHOCK
COULD CAUSE SEVERE
BURNS OR INJURY. DO
NOT TOUCH ELECTRICAL
WIRES OR COMPONENTS
WHILE THE ENGINE IS
RUNNING. DISCONNECT
THE BATTERY BEFORE
SERVICING THIS UNIT TO
PREVENT ACCIDENTAL
STARTING.**

44-066 A

44-066, WARNING, ELECTRICAL SHOCK



**READ THE OPERATOR'S MANUAL
BEFORE INSTALLING OR
STARTING THIS UNIT. FAILURE TO
ADHERE TO INSTRUCTIONS CAN
RESULT IN SEVERE PERSONAL
INJURY OR COULD BE FATAL.
REPLACEMENT
MANUALS CAN BE PURCHASED
FROM:**

Sapphire Scientific
2604 Liberator
Prescott, AZ 86301

44-067 A

44-067, WARNING, READ MANUAL



**ROTATING MACHINERY
CAN CAUSE INJURY OR
COULD BE FATAL.
KEEP ALL GUARDS
AND SAFETY DEVICES
IN PLACE.**

44-085 A

44-085, WARNING, ROTATING MACHINERY

**ROTATING
MACHINERY.
WATER UNDER
PRESSURE AT HIGH
TEMPERATURE.
IMPROPER
MODIFICATION OF
EQUIPMENT CAN
CAUSE SEVERE
PERSONAL INJURY
OR COULD BE
FATAL.**



**DO NOT MODIFY
UNIT WITHOUT
WRITTEN
PERMISSION
FROM
MANUFACTURER**

44-082 A

44-082, DANGER, ROTATING MACHINERY



44-084, CAUTION, HOT SURFACE

DECAL, PRODUCT HVE-LL



ELECTRICAL DIAGRAM

