

# 870<sup>H</sup> LIQUID COOLED

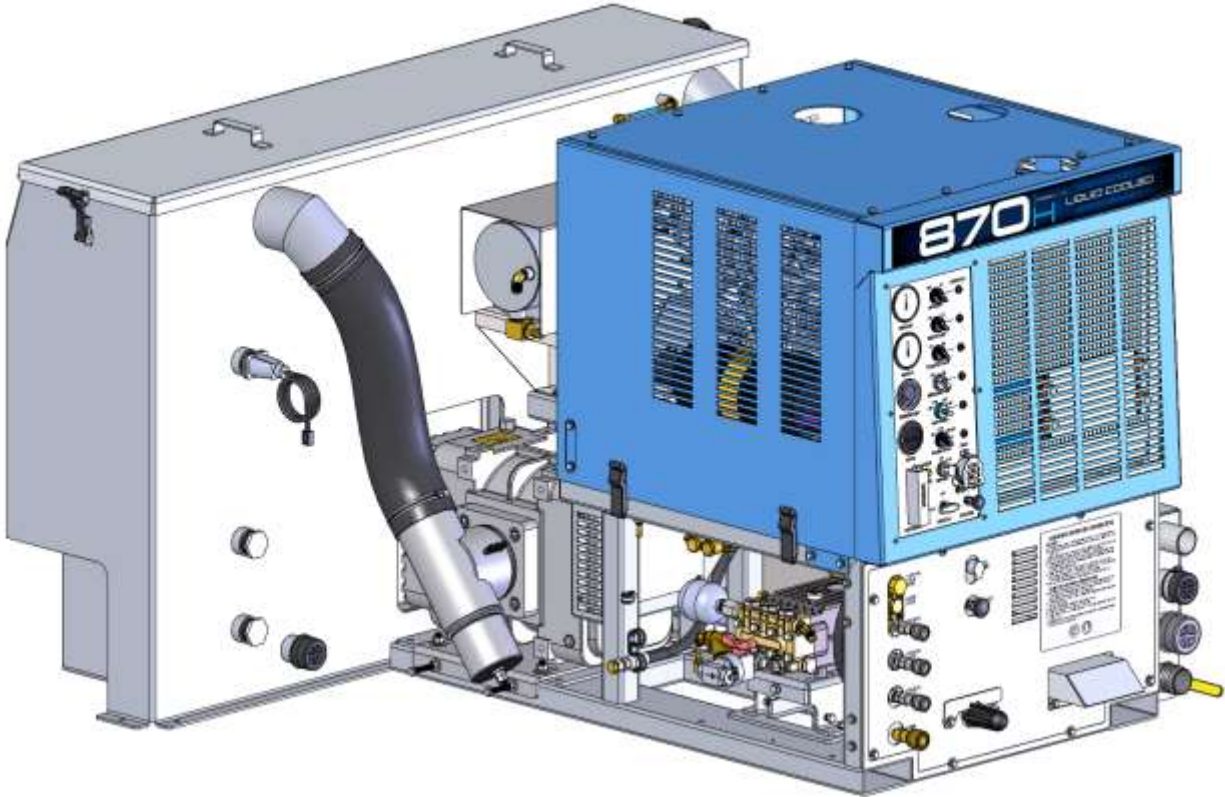

## SERVICE AND OPERATION MANUAL



2604 Liberator, Prescott, AZ 86301

1-866-445-3030

**Congratulations** on your purchase of the **870H** Truck-mount cleaning unit. This manual is a guide for operating and servicing your **Sapphire Scientific** equipment.

Proper operation and service are necessary to ensure the outstanding performance of this unit. When properly maintained, your unit will have a long and trouble-free life.

The following service methods outlined in this manual are detailed in a manner that operation and servicing may be performed properly and safely. Because service levels vary due to the skill of the mechanic, tools and parts availability, ensure that prior to attempting any maintenance or repair, you are familiar with the equipment and have all the proper tools to complete the task. Please call a **Sapphire Scientific** service representative at 1-800-932-3030 for help with maintenance, repair and warranty related questions.

The headings “**WARNING**” and “**CAUTION**” are utilized to warn you that steps must be taken to prevent personal injury or damage to the equipment. Please make sure that you have read and understand these instructions entirely before proceeding with the operation of this unit.

**THIS UNIT MUST BE INSTALLED BY THE DEALER THAT YOU PURCHASED IT FROM IN ACCORDANCE WITH THE SAPPHIRE SCIENTIFIC INSTALLATION PROCEDURES.**

This unit was manufactured by:

**Sapphire Scientific**  
2604 Liberator  
Prescott, AZ 86301  
USA



**WARNING!** Do not alter or modify your **870H** in any way. Use only replacement parts authorized by **Sapphire Scientific**. Modifications or use of unapproved parts could create a hazard and will void your warranty. Contact a **Sapphire Scientific** service representative at 1-800-932-3030 for assistance.

**Be sure to fill out the warranty card online at: <http://www.sapphirescientific.com>**

This service and operations manual is written specifically for the **Sapphire Scientific 870H** unit.

Published by **Sapphire Scientific**.  
First Printing: March 2016  
Printed in USA

**870H MANUAL**  
**SAPPHIRE SCIENTIFIC P/N 49-146**  
**REVISION A, MARCH 2016**

The information contained in this document is subject to change without notice and does not represent a commitment on the part of **Sapphire Scientific**.

All rights reserved. Copyright 2016 by **Sapphire Scientific**. No part of this work may be used or reproduced in any form or means without the express written consent and permission of **Sapphire Scientific**.

## **SAPPHIRE SCIENTIFIC LIMITED WARRANTY**

### **Sapphire Scientific 870H**

#### **What Does This Warranty Cover?**

This warranty covers the Sapphire Scientific Model 870H and is provided to the original purchaser only.

#### **How Long Does This Warranty Last?**

This warranty runs for:

Two (2) years from the date of installation on parts and labor (Excluding normal maintenance items.) Factory installed original belts are covered for 500 hours. Recovery tank and frame are covered for five years. All other components including seals, o-rings and electrical components are covered for the entire three year warranty period.

#### **What Sapphire Scientific Will Do:**

If a defect in materials or workmanship occurs within the warranty period, Sapphire Scientific at its election will repair or replace the defective part at no charge.

#### **What This Warranty Does Not Cover:**

This warranty does not cover or apply to defects due directly or indirectly to misuse, abuse, disassembly, alteration, corrosive chemicals, improper voltage, improper fuel, fire, flood, negligence, accident, improperly or incorrectly performed maintenance or repair, or failure to perform necessary or recommended maintenance or repair (See your Owner's Manual) or if the use of this product is not in compliance with the instructions and specifications for its use. This warranty does not cover normal maintenance items such as air and oil filters, lubricants and tune up parts. Paint is not covered. Water box, recovery tank and frame are covered for five years. All other components including seals, o-rings and electrical components are covered for the entire two year warranty period. We limit all implied warranties to: Two (2) years from the installation date on parts and labor.

OTHER THAN THE WARRANTIES PROVIDED HEREIN, SAPPHIRE SCIENTIFIC MAKES NO EXPRESS OR IMPLIED, ORAL OR WRITTEN WARRANTIES WITH RESPECT TO THIS PRODUCT OR WORKMANSHIP AND ALL WARRANTIES IMPLIED BY LAW INCLUDING ANY WARRANTIES OF MERCHANTABILITY OR FITNESS FOR A PARTICULAR PURPOSE ARE LIMITED TO THE DURATION OF THIS WARRANTY. **Some states do not allow limitations on how long an implied warranty lasts, so the above limitations may not apply to you.** WE SHALL IN NO EVENT BE LIABLE FOR DEATH, INJURIES TO PERSONS OR PROPERTY OR FOR INCIDENTAL, CONTINGENT, SPECIAL OR CONSEQUENTIAL DAMAGES ARISING FROM USE OF OUR PRODUCTS. **Some states do not allow the exclusion or limitation of incidental or consequential damages, so the above limitation or exclusion may not apply to you.**

#### **How Do I Get Service?**

In order to be eligible for service under this warranty you MUST do the following: (a) fill out the warranty registration card on-line within thirty (30) days of the installation of our product; (b) write or call a service representative at Sapphire Scientific for a return material authorization (RMA); and (c) have the serial number available. Proof of proper maintenance may be required before warranty is granted.

#### **Contact us at:**

Sapphire Scientific  
2604 Liberator, Prescott, AZ 86301  
Phone: 928-445-3030 / 866-445-3030

If Sapphire Scientific uncovers a defect we will repair or replace the product, at our election. Ground shipping and transportation costs will be covered by the manufacturer. Returning defective parts to the manufacturer, if required, shall be the responsibility of the purchaser. Warranty may be denied if defective parts are not returned within the allotted 30 days. If it is determined that there is no defect in the product, or that the defect resulted from causes not within the scope of our warranty, then the product will be repaired or replaced only at your request and at your expense and you must bear all shipping costs.

#### **How Does State Law Apply?**

This warranty gives you specific legal rights, and you may also have other rights which vary from state to state.

# TABLE OF CONTENTS

<b>SECTION ONE: GENERAL INFORMATION</b>	<b>1</b>
CONTACT INFORMATION .....	2
SAFETY - WARNINGS AND CAUTIONS.....	3
SPECIFICATIONS .....	8
REQUIREMENTS .....	9
RECEIVING YOUR TRUCK-MOUNT SYSTEM .....	12
<b>SECTION TWO: INSTALLATION</b>	<b>14</b>
INSTALLATION .....	15
<b>SECTION THREE: OPERATION</b>	<b>21</b>
UNDERSTANDING THE SYSTEMS.....	22
OPERATION .....	27
FREEZE PROTECTION .....	37
<b>SECTION FOUR: SERVICE AND MAINTENANCE</b>	<b>40</b>
OPERATOR MAINTENANCE CHART .....	41
DEALER SERVICE CHART .....	42
MAINTENANCE .....	43
GENERAL SERVICE ADJUSTMENTS.....	50
TROUBLESHOOTING.....	56
<b>SECTION FIVE: PARTS AND ACCESSORIES</b>	<b>62</b>
ILLUSTRATED PARTS LISTING .....	63
<b>SECTION SIX: REFERENCE GUIDES</b>	<b>97</b>
WATER FLOW DIAGRAM .....	98
CHEMICAL FLOW DIAGRAM.....	99
WIRING DIAGRAM .....	100
FUEL LINE INSTALLAION .....	101
ENGINE DIAGNOSTIC CODES.....	108

## SECTION ONE: GENERAL INFORMATION

<b>CONTACT INFORMATION</b> .....	<b>2</b>
<b>WARNINGS AND CAUTIONS</b> .....	<b>3</b>
<b>SPECIFICATIONS</b>	
TORQUE VALUES.....	8
<b>REQUIREMENTS</b>	
INSTALLATION REQUIREMENTS.....	9
FUEL REQUIREMENTS.....	9
ENGINE OIL REQUIREMENTS.....	10
WATER REQUIREMENTS.....	10
CHEMICAL REQUIREMENTS.....	11
ANTIFREEZE COOLANT REQUIREMENTS.....	11
<b>RECEIVING YOUR TRUCK-MOUNT SYSTEM</b>	
ACCEPTANCE OF SHIPMENT.....	12
EQUIPMENT LISTING.....	12
OPTIONAL EQUIPMENT.....	12
FUEL HOOK-UP KITS BY VEHICLE.....	13

## CONTACT INFORMATION

For information about unit operation, maintenance or repair of your Sapphire Scientific equipment, please contact your local distributor.

To locate a local distributor, please visit our web site: <http://www.sapphirescientific.com/>

North American Distributors:

[http://www.sapphirescientific.com/SSX\\_DistributorListings\\_NorthAmerica.aspx](http://www.sapphirescientific.com/SSX_DistributorListings_NorthAmerica.aspx)

If you need to contact Sapphire Scientific directly, for questions regarding this manual, service questions that cannot be resolved by your distributor, or other general information, please contact our service department here:

Phone: 1-800-932-3030

Service Email: [service@sapphirescientific.com](mailto:service@sapphirescientific.com)

Please fill in the information below so that you will have it on hand when contacting your distributor or Sapphire Scientific.

**Serial Number:**

---

**Date of Purchase:**

---

**Purchased From (Distributor):**

---

## WARNINGS AND CAUTIONS

### **WARNING**

Sapphire Scientific uses this WARNING symbol throughout the manual to warn of the possibility of physical injury or fatality. Please read all warnings carefully before operating the equipment.

### **CAUTION**

Sapphire Scientific uses this CAUTION symbol throughout the manual to warn of the possibility of damage to equipment or personal property.

**FOR YOUR SAFETY**

The following warning labels are on your **870H** console. These labels point out important **WARNINGS** and **CAUTIONS**, which must be followed at **ALL** times. Failure to follow these warnings could result in injury or fatality to yourself and/or others or property damage. Please follow these instructions carefully! **Do NOT remove these decals.**

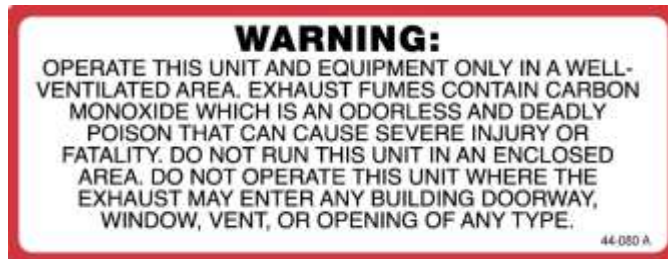

ROTATING MACHINERY. WATER UNDER PRESSURE AT HIGH TEMPERATURE. IMPROPER MODIFICATION OF EQUIPMENT CAN CAUSE SEVERE PERSONAL INJURY OR COULD BE FATAL.





 **WARNING**

1. **Read the operator’s manual before starting this unit.**  
Failure to adhere to instructions could result in severe personal injury or could be fatal.

 **WARNING**

2. **Operate your equipment in a well-ventilated area.**  
Exhaust fumes contain carbon monoxide, which is an odorless and deadly poison that can cause severe injury or death. **DO NOT** run this equipment in an enclosed area. **DO NOT** operate this unit where the exhaust may enter a building doorway, window, vent or other opening.



 **WARNING**

3. **Gasoline is extremely flammable and its vapors can explode if ignited.** Store gasoline only in approved containers, in well-ventilated, unoccupied buildings and away from sparks or flames.

 **WARNING**

4. **DO NOT** operate unit if gasoline is spilled. Do not turn ignition switch until the gasoline has been cleaned up. Never use gasoline for cleaning purposes.

 **WARNING**

5. **DO NOT** place hands, feet, hair, clothing or any body parts near rotating or moving parts. Rotating machinery can cause severe injury or death.

 **WARNING**

6. **NEVER** operate this unit without belt and safety guards. High speed moving parts, such as belts and pulleys should be avoided while the unit is running. Severe injury, fatality and/or damage may result.

 **WARNING**

7. **NEVER** service a unit while it is running. High speed mechanical parts as well as high temperature components and fluids may result in severe injury or fatality.

 **WARNING**

8. Engine and vacuum pump components, hoses and fittings will be extremely hot from operation. To prevent severe burns, **DO NOT** touch these areas while the unit is running, or shortly after the unit is shut off.

 **WARNING**

9. **DO NOT** touch any part of the exhaust system while the system is running or for 30 minutes after the unit is shut off. Severe burns could result.

 **WARNING**

10. **Battery acid contains sulfuric acid.** To prevent acid burns, avoid contact with skin, eyes and clothing. Batteries also produce explosive hydrogen gases while charging. To prevent fire or explosion, charge batteries only in a well ventilated area. Keep sparks, open flames, as well as other sources of ignition away from battery at all times. Remove all jewelry prior to servicing batteries. Keep batteries out of the reach of children.

**Before disconnecting** the negative (-) ground cable, ensure that all switches are in the off position. If on, a spark could occur at the ground connection terminal which could cause an explosion if hydrogen gas or gasoline vapors are present. **ALWAYS** disconnect the negative (-) terminal first

 **WARNING**

11. **DO NOT** smoke around the equipment. Gas fumes could accumulate and ignite. Battery gasses are extremely flammable. This will prevent possible explosions.

 **WARNING**

12. **NEVER** cut or splice any of the equipment fuel lines. This will result in fuel leaks and potentially dangerous conditions. Use only the provided fuel hose for fuel lines.

 **WARNING**

13. The Occupational and Health Administration (OSHA) recommends the use of hearing protection when a technician is exposed to an average of 85 decibels (this is an average of exposure over an 8 hour period). This equipment can produce 85 decibels at a distance of 10 feet. Please check with your local state agencies to see if OSHA standards apply to your application.

 **WARNING**

15. California Proposition 65 Warning: Engine exhaust from this product contains chemicals known by the State of California to cause cancer, birth defects, or other reproductive harm.

 **WARNING**

**ENGINE EXHAUST FROM THIS PRODUCT CONTAINS CHEMICALS KNOWN BY THE STATE OF CALIFORNIA TO CAUSE CANCER, BIRTH DEFECTS, OR OTHER REPRODUCTIVE HARM.**

**OPERATE THIS UNIT AND EQUIPMENT ONLY IN A WELL-VENTILATED AREA.**

 **CAUTION**

1. Always keep your equipment clean and maintained. Proper performance relies heavily on regularly maintained hoses, tools, filters and strainer basket.

 **CAUTION**

2. Ensure that you have received proper training and are familiar with the start-up and shut-down procedures prior to operation.

 **CAUTION**

3. **DO NOT** alter or modify your **870H** in any way. Use only replacement parts authorized by **Sapphire Scientific**. Modifications or use of unapproved parts could create a hazard and will void your warranty. This includes the use of any open ended hoses.

**SPECIFICATIONS**

Engine Speed	2400 RPM (High Speed/No Load)
	2000 RPM (Med Speed/No Load)
	1600 RPM (Low Speed/No Load)
	1300 RPM (Idle/No Load)
Vacuum Pump RPM	3463 RPM @ 2400 Engine RPM
Vacuum Relief Valve	13 in. Hg
Pressure Pump RPM	1392 RPM @ 2400 Engine RPM
Pressure Pump GPM	5.6 GPM @ 2400 Engine RPM
Pressure Pump Max PSI	2500 PSI
Recovery Tank Capacity at Shut-Off	100 gallons
Recovery Tank Gross Capacity	120 gallons
Console only weight	1434 lbs.
Console/Tank (with hoses)	1864 lbs. Approximately
Console/Tank Weight (full recovery tank)	2782 lbs. Approximately

**TORQUE VALUES**

Engine Flywheel Bolts	89 – 96 ft./lbs. (1068 – 1152 in./lbs.)
Crankshaft Pulley Bolts	103 – 111 ft./lbs. (1236 – 1332 in./lbs.)
Vacuum Pump Hub	15 ft./lbs. (180 in./lbs.)

**JET SIZING**

Sapphire Scientific recommends that the total floor tool tip size be #6

## INSTALLATION REQUIREMENTS

Prior to beginning the installation, read the **ENTIRE Installation** section of this manual. Since the **SAPPHIRE SCIENTIFIC 870H** kit weighs approximately 1864 lbs., please adhere to the following recommendations prior to installing the unit.



1. **DO NOT** exceed the vehicle's payload capacity. This will prevent unsafe or hazardous driving conditions. Before installing any components into the vehicle, check with the vehicle manufacturer for the Gross Vehicle Weight Rating (GVWR). GVWR is the maximum allowable combined weight of the vehicle, including all passengers, fuel, fluids, tools and cargo.

**Example:** If the GVWR for a vehicle is 9600 lbs. and the vehicle has a base curb weight of 6406 lbs., this leaves a payload capacity of 3194 lbs. (GVWR - Curb Weight = Payload Capacity).

2. If mounting the unit in a trailer, ensure that the trailer is rated for the total weight of the unit and trailer. Electric or hydraulic brakes must be provided, and strict compliance with all State and Federal laws must be maintained.

3. SAPPHIRE SCIENTIFIC recommends using only a dual axle trailer. If mounting in a trailer, the SAPPHIRE SCIENTIFIC 870H console must be positioned so that it balances properly with respect to the trailer axles. Ten percent (10%) of the unit's total overall weight (w/o accessories or water) should be on the tongue.

4. Adequate ventilation with either two sets of doors or a roof ventilation system is required.

5. Tires must have a load rating in excess of the combined unit and vehicle/trailer weight.

6. SAPPHIRE SCIENTIFIC does not recommend using any type of flooring materials that absorb water. This condition will result in rust and corrosion of the vehicle floor.

7. Insulation under rubber mats should be removed prior to installation of the unit.

## FUEL REQUIREMENTS

**Use unleaded fuel ONLY.** Use only fresh, clean unleaded gasoline with a minimum octane rating of 87. **Do Not** use high octane gasoline. Gasoline with up to, not exceeding, 10% ethanol is acceptable.

**Gasoline older than 30 days must be discarded and replaced with fresh gasoline.**

**NOTE:** Using other gasoline/alcohol blends including E20 and E85 will cause damage to engine components and will void the warranty.

## ENGINE OIL REQUIREMENTS

Use engine oil that is API (American Petroleum Institute) Service Grade Certified, class SG or above. **Do not use additives.**

An SAE viscosity grade is used to specify the viscosity of engine oil. SAE 10W-30 specifies multiple viscosity engine oil. When choosing engine oil, consider the range of temperatures the unit will be operated in before the next oil change. Select engine oil that is best suited to your area’s particular ambient temperature range and variation. Sapphire Scientific recommends using synthetic SAE 10W-30 engine oil.

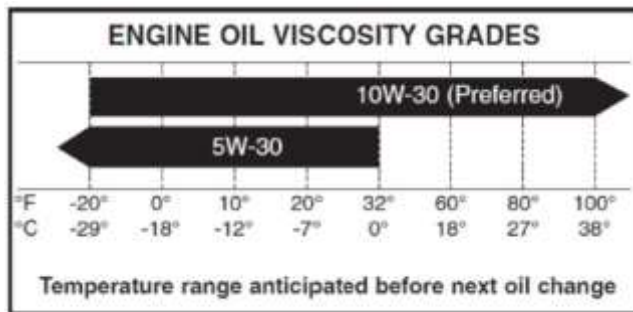

*Temperature/Engine Oil Viscosity*

**NOTE:** Using lower service class oil or extending oil change intervals longer than recommended can cause engine damage.

Engine oil capacity	3.3 L 3.48 U.S. qts
---------------------	------------------------

Tightening torque	Oil Drain Plug	40 – 45 Nm 400 – 450 Kg.cm 30 – 33 lb.ft
	Oil Filter	12 – 16 Nm 120 – 160 Kg.cm 9 – 12 lb.ft

## WATER REQUIREMENTS

Because hard water deposits will damage the plumbing and heat exchange systems on this unit, Sapphire Scientific recommends that a high quality water softener be used in areas where the water hardness exceeds 3½ grains. If a water softener is used, it must have a flow capacity of at least five (5) GPM or greater, without any hose constrictions.

The use of a water softening system will reduce maintenance and reduce down time caused by hard water scaling. It will also enhance the performance of cleaning chemicals, which will result in greater efficiency in lower concentrations.

## CHEMICAL REQUIREMENTS

The Sapphire Scientific Model 870H Truck-mount unit's unique last step chemical injection system can be used with a wide variety of water diluted chemical compounds, either acidic or alkaline, depending on the work to be performed. We recommend using only Chemspec brand chemistry.

## ANTIFREEZE COOLANT REQUIREMENTS

Always use a quality, permanent ethylene glycol based for aluminum antifreeze coolant.

Use a 50% mixture ratio of antifreeze in coolant. Distilled, soft or pure rain water is recommended for the cooling system.

**Note:** Antifreeze and water must be mixed thoroughly before putting into the coolant system or hot spots may develop leading to engine overheating.

## RECEIVING YOUR TRUCK MOUNT SYSTEM

### **DEALER RESPONSIBILITY**

THE DEALER THAT YOU PURCHASED THIS EXTRACTION SYSTEM FROM IS RESPONSIBLE FOR THE PROPER INSTALLATION OF THIS MACHINE.

**THE DEALER IS ALSO RESPONSIBLE FOR THE PROPER INITIAL TRAINING OF YOUR OPERATORS AND MAINTENANCE PERSONNEL.**

### **ACCEPTANCE OF SHIPMENT**

This 870H system was thoroughly tested, checked and inspected in its entirety prior to leaving our manufacturing facility. When receiving your unit, please make the following acceptance check:

1. The unit should not show any signs of damage. If there is damage, notify the deliverer immediately.
2. Carefully check your equipment. The 870H system should arrive with the following items as well as any additional optional accessories you may have ordered:

### **EQUIPMENT LISTING**

- 870H Console
- 870H Recovery Tank
- Operation and Service Manual
- Installation hardware and mounting plates
- Hoses and clamps for console to recovery tank connection and manual drain
- Fuel Pump and Filter
- Group 24 Battery Holder
- Vacuum Inlet Filters (in Recovery Tank)
- Stainless Steel Strainer Basket
- 100 ft. of 2 in. Vacuum Hose
- 100 ft of Solution Hose
- Wand

### **OPTIONAL EQUIPMENT** (contact Sapphire Scientific to order separately)

<b>DESCRIPTION</b>	<b>PART NUMBER</b>
50 ft. 2 in. Vacuum Hose	18-003
50 ft. 2-1/2 in. Vacuum Hose	18-333
Hose connector	21-003
50 ft. high pressure solution hose	18-000
50 ft. high pressure solution hose w/valve	18-001
Automatic Waste Pump Kit	68-158
Demand Pump System	68-002



**FUEL HOOK-UP KITS BY VEHICLE**

- Chevy 1997 to 2002 FI..... 69-003FI
- Chevy 2003 FI..... 69-018FI
- Chevy 2004+ Hook-Up Kit ..... 69-033
- Chevy Box Truck 2004+ ..... 69-081
- Dodge 1997 to 2002 FI..... 69-004FI
- Ford FI ..... 69-005FI
- Ford 2004 – 2010 ..... 69-061
- Ford 2011+ ..... 69-331
- Ford Box Truck 2004+ ..... 68-077
- Nissan NV ..... 69-376

## SECTION TWO: INSTALLATION

### INSTALLATION

LIFTING THE UNIT INTO THE VEHICLE .....	15
POSITIONING THE UNIT INTO THE VEHICLE.....	15
FASTENING DOWN THE UNIT AND RECOVERY TANK .....	16
DIMENSIONAL DIAGRAMS .....	17
INSTALLATION OF FUEL LINES.....	18
TRAILER FUEL TANK AND FUEL LINE INSTALLATION .....	18
BATTERY CONNECTION .....	19
FIRE EXTINGUISHER.....	19
CONSOLE TO WASTE TANK CONNECTIONS .....	20

## INSTALLATION



**This unit must be bolted to the floor of the vehicle by an AUTHORIZED DISTRIBUTOR.**

### **LIFTING THE UNIT INTO THE VEHICLE**

The **870H** console weighs approximately 1434 lbs., a forklift is necessary to place the unit into the vehicle. Place the forks into the fork pockets. Move the unit into the desired position.

### **POSITIONING THE UNIT INTO THE VEHICLE**

Vehicles vary in size and openings. Owners have different preferences on where in the vehicle they want their units positioned. **Sapphire Scientific** strongly recommends a side door installation for the **870H**. We **DO NOT** recommend a rear door installation.

1. Ensure that enough space is provided to assure adequate engine ventilation as well as room for service and maintenance.
2. The operating weight of the complete installation (which includes water weight) with recovery tank and all accessories **MUST NOT** exceed the vehicle's axle weight limit.

**NOTE: This unit may not fit with a standard installation configuration in some of the European style vans which offer a narrower body style.**

## **FASTENING DOWN THE UNIT AND RECOVERY TANK**



**Prior to drilling any holes in the vehicle floor, ensure that while drilling, you will not damage the fuel tank, fuel lines, or any other vital components, which could affect the safety and or operation of the vehicle.**

1. The console and recovery tank mounting holes will serve as a template. Drill eight (8)  $1\frac{13}{32}$  in. diameter holes for the console and seven (7)  $1\frac{13}{32}$  in. diameter holes for the recovery tank.
2. Using the provided mounting hardware kit:
  - a. Insert grade 5, 3/8-16 × 4 in. hex head cap screws with flat washers through the console mounting holes, and grade 5, 3/8-16 × 4 in. hex head cap screws with flat washers through the recovery tank mounting holes.
  - b. Install the provided mounting plates underneath the vehicle floor.
  - c. Screw the provided 3/8-16 hex head lock nuts on to the mounting bolts and tighten until the console and recovery tank are firmly attached to the vehicle floor.

**DIMENSIONAL DIAGRAM**

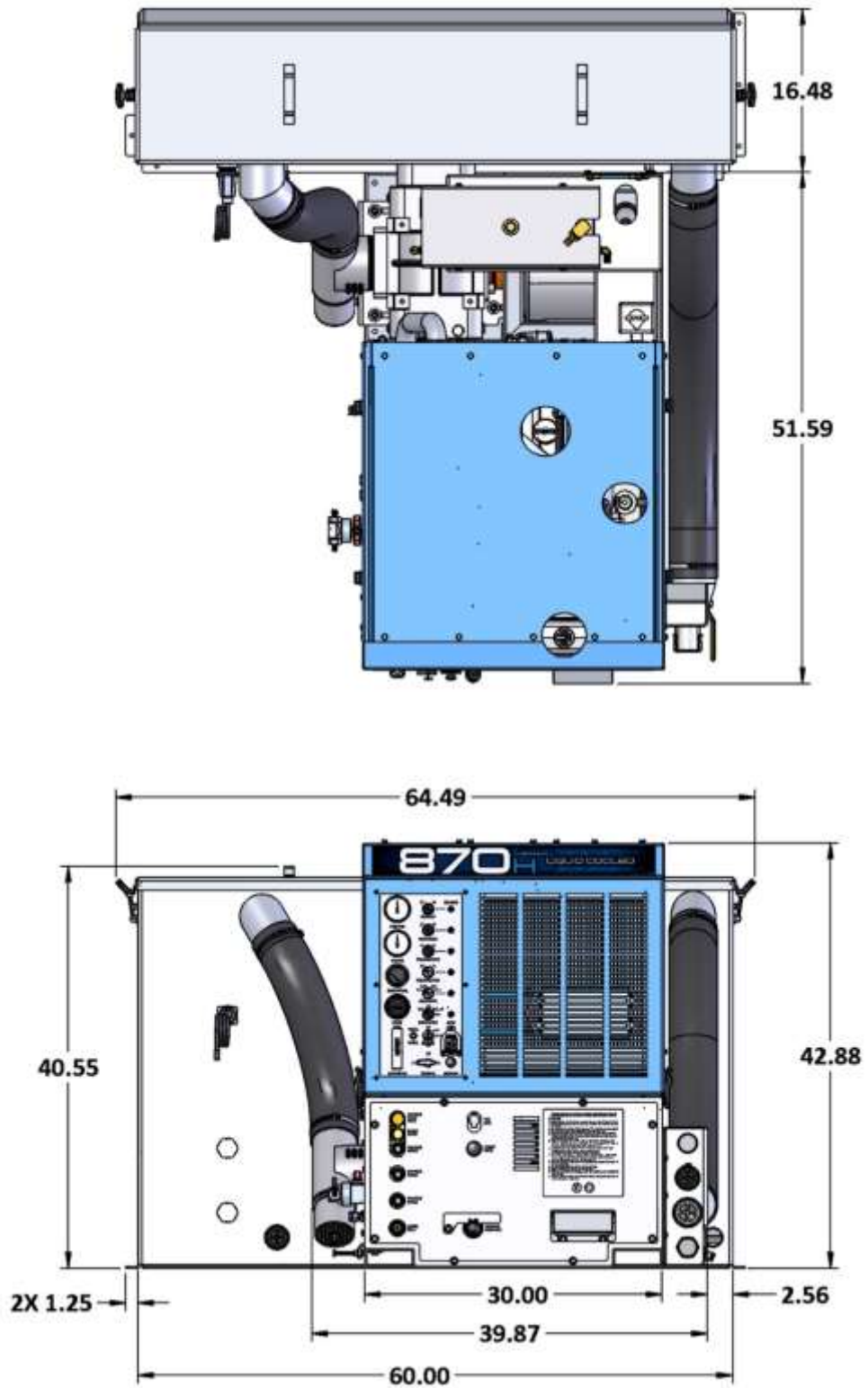

## **INSTALLATION OF FUEL LINES**



**CAUTION**  
READ THESE INSTRUCTIONS ENTIRELY BEFORE PROCEEDING.



**WARNING!**

The Vehicle fuel lines should **NOT** be spliced under **ANY** circumstances. Severe injury or fatality could result.

**DO NOT** damage the vehicle in any way during the installation. When routing fuel lines, **DO NOT** configure the hoses in any location where the hoses or vehicle could be damaged. Avoid contact with moving parts, areas of high temperature, brake lines, fuel lines, catalytic converters, exhaust pipes, mufflers or sharp objects. Excess heat from exhaust or other heat sources may cause the fuel pump to work improperly.

## **TRAILER FUEL TANK AND FUEL LINE INSTALLATION**

The following are recommendations for trailer installations:

- A. Strict compliance with all federal and state laws must be maintained.
- B. Use only fuel tanks that are manufactured specifically for gasoline, have proper vented filling caps, and outlet connections that are the same size as the inlet and return connections on the unit.
- C. **DO NOT** install fuel tanks inside any type of enclosed trailer or vehicle.



**WARNING!**

**NEVER** carry gasoline or flammable materials in an enclosed trailer or vehicle.

**NEVER** store any type of flammable material in an enclosed trailer or vehicle.

- D. Always mount fuel tanks where they will be protected from any vehicle collision.
- E. When installing fuel lines from the fuel tank to the unit, use the proper size fuel line.

**SEE SECTION SIX FOR REFERENCE GUIDES ON FUEL LINE INSTALLATION**

## **BATTERY CONNECTION**



### **EXPLOSIVE GASES, DANGEROUS GASES!**

Batteries contain sulfuric acid. To prevent acid burns, avoid contact with skin, eyes and clothing. Batteries also produce explosive hydrogen gases while charging. To prevent fire or explosion, charge batteries only in a well ventilated area. Keep sparks, open flames, as well as any other sources of ignition away from batteries at all times. Remove all jewelry prior to servicing batteries. Keep batteries out of the reach of children.

Before disconnecting the negative (-) ground cable, ensure that all switches are in the OFF position. If ON, a spark could occur at the ground connection terminal, which could cause an explosion if hydrogen gas or gasoline vapors are present. ALWAYS disconnect the negative (-) terminal first.

- A. Attach the red positive (+) battery cable from the starter solenoid on the console to the positive (+) terminal on the battery and tighten down the nut.
- B. Attach the black negative (-) battery cable from the ground on the console to the negative (-) terminal on the battery and tighten down the nut.

## **FIRE EXTINGUISHER**

Sapphire Scientific, and many government agencies, recommend that a fire extinguisher rated for A, B, and C type fires be installed into any commercial vehicle.

**CONSOLE TO WASTE TANK CONNECTIONS**

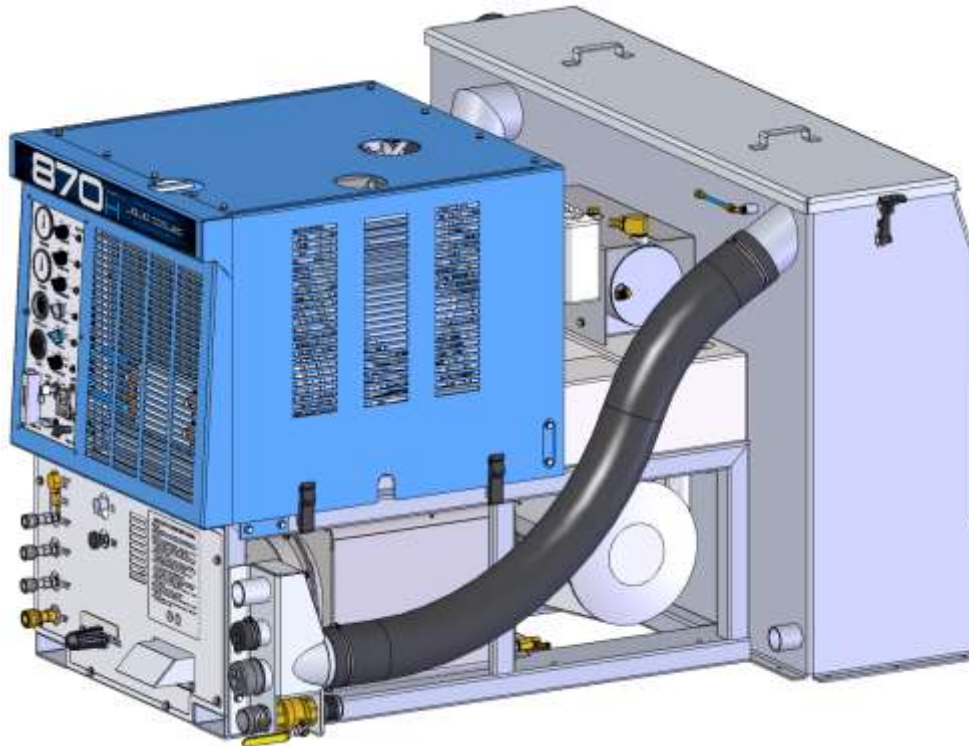
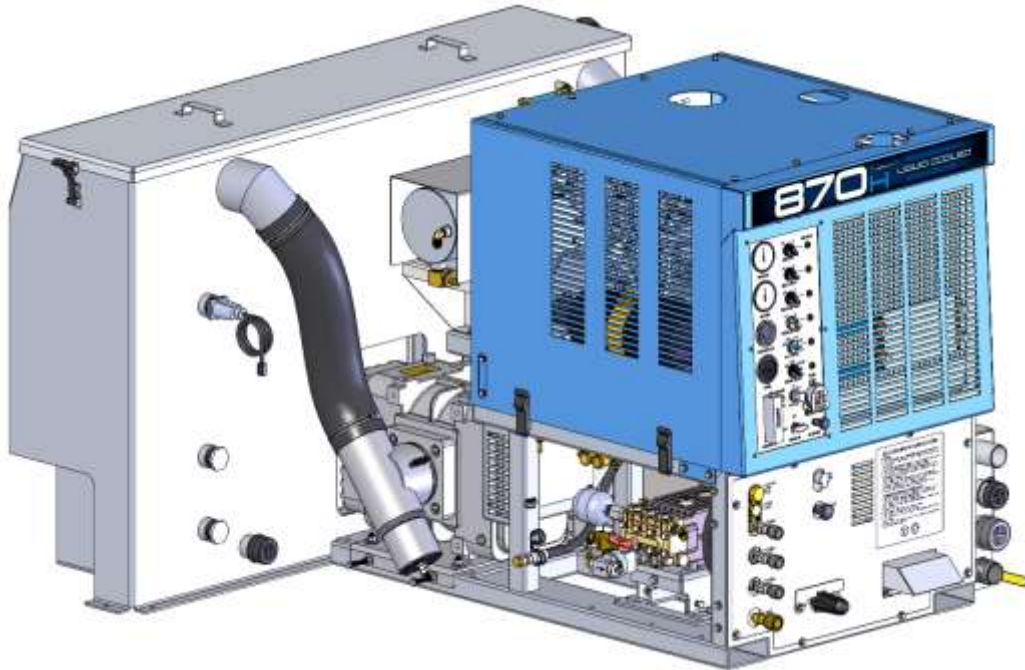



## SECTION THREE: OPERATION

### UNDERSTANDING THE SYSTEMS

WATER HEATING SYSTEM .....	22
VACUUM SYSTEM .....	24
CHEMICAL PUMPING .....	26

### OPERATION

UNDERSTANDING THE INSTRUMENT PANEL .....	28
UNDERSTANDING THE LOWER PANEL .....	30
PREPARATION .....	32
STARTING THE UNIT .....	33
PRIMING THE CHEMICAL PUMP .....	33
AUTOMATIC WASTE PUMP .....	34
OPERATING THE UNIT .....	34
SHUT-DOWN AND DAILY MAINTANENCE .....	35
AUTOMATIC SHUT DOWNS .....	36

### FREEZE PROTECTION

WINTERIZING YOUR UNIT .....	37
-----------------------------	----

## UNDERSTANDING THE SYSTEMS

**NOTE: Read and understand this section of the manual entirely before operating the unit.**

Prior to proceeding into the operations and maintenance sections of this manual it is recommended that you acquire a basic understanding of how the unit functions.

### **WATER HEATING SYSTEM**

Cold water enters the console through the water inlet connection on the lower front panel. The pressure regulator behind the inlet port regulates the incoming water pressure and filters debris. The water then flows to the pressurized water box **(1)** where it is pre-heated by passive radiant heat generated by the engine and blower exhausts.

The water then flows to the pressure pump **(2)** where it is pressurized. From there it is sent to the pressure regulator **(3)** where bypass water is recirculated into the water box **(4a)** and pressurized water is sent to the engine coolant heat exchanger **(4)** where it is heated through stainless steel finned-tube coil by the engine coolant temperature.

From the engine coolant heat exchanger, water continues to the main heat exchanger located inside the water box **(5)** where it is further heated by the engine and blower exhausts through a stainless steel finned-tube coil.

This hot water then flows to the solution outlet manifold **(6)** that contains a strainer and a check valve, which is where the chemical injection takes place.

In order to maintain an even operating water temperature, hot water that is not being used is circulated back into the system by way of the bypass manifold **(6a)**. The water enters the bypass cooler **(6b)** where temperature is dropped before coming back to the water box **(6c)**.

The hot solution mixture of water and chemicals then flows out of the solution outlet manifold to the cleaning tool **(7)**.

(SEE DIAGRAM ON FOLLOWING PAGE)

## WATER HEATING SYSTEM DIAGRAM

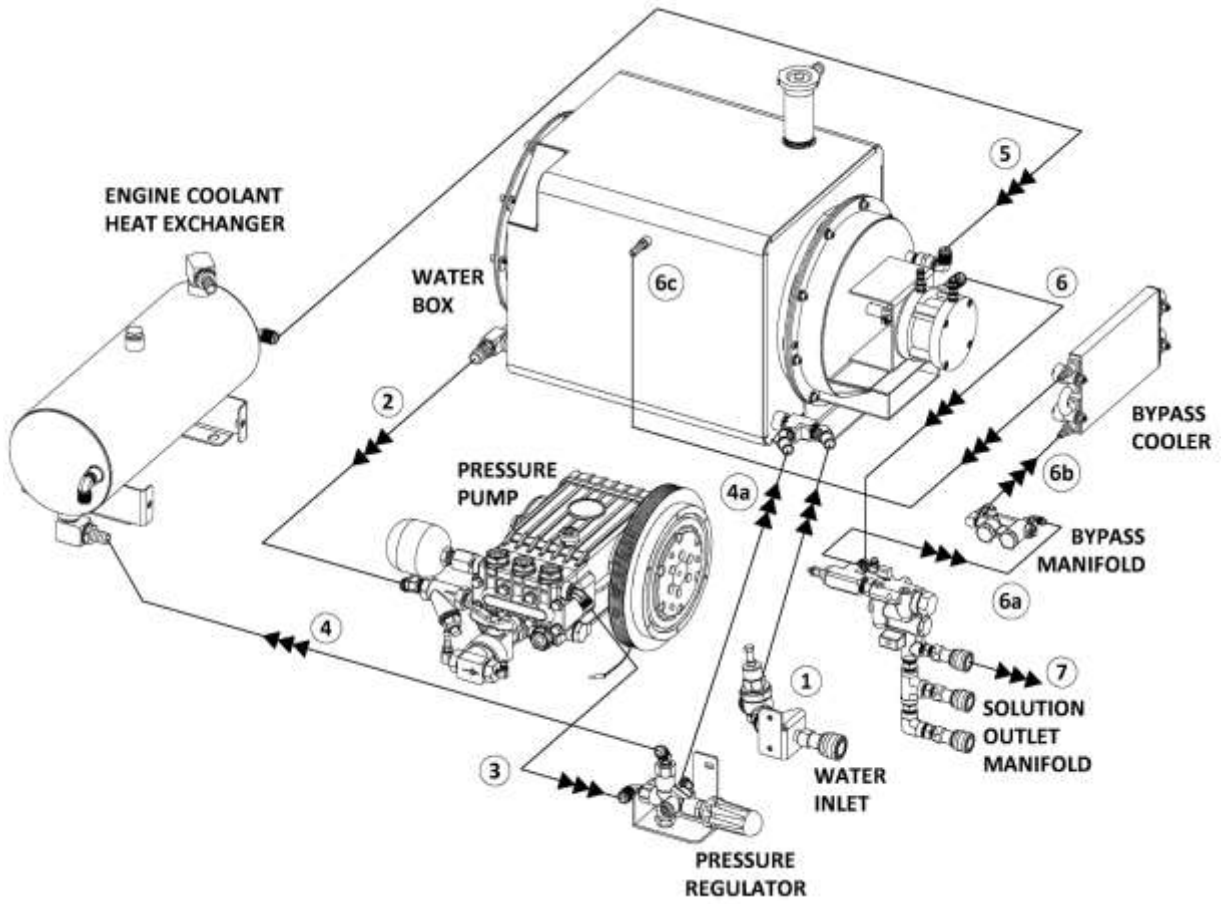

## VACUUM SYSTEM

The flow of vacuum is initiated by the vacuum pump, which draws air through the recovery tank. A mixture of air and water is drawn into the recovery tank through a vacuum inlet near the front of the machine. The air and water continue to the recovery tank to a strainer basket. Here in the recovery tank, water and air separate. Water is deposited into the recovery tank while the air exits through a 100 mesh filtration system, into the vacuum pump. A relief valve is installed for vacuum pump protection.

The air is discharged from the vacuum pump through a spiral silencer, then exiting through the exhaust pipe on the front of the unit.

A high level shut off sensor is located on the front of the recovery tank and will shut down the unit before the tank is at full capacity. This protects the vacuum pump from water damage.

**Note:** Recovery tank high level shut off will not shut the unit off due to high levels of foam.

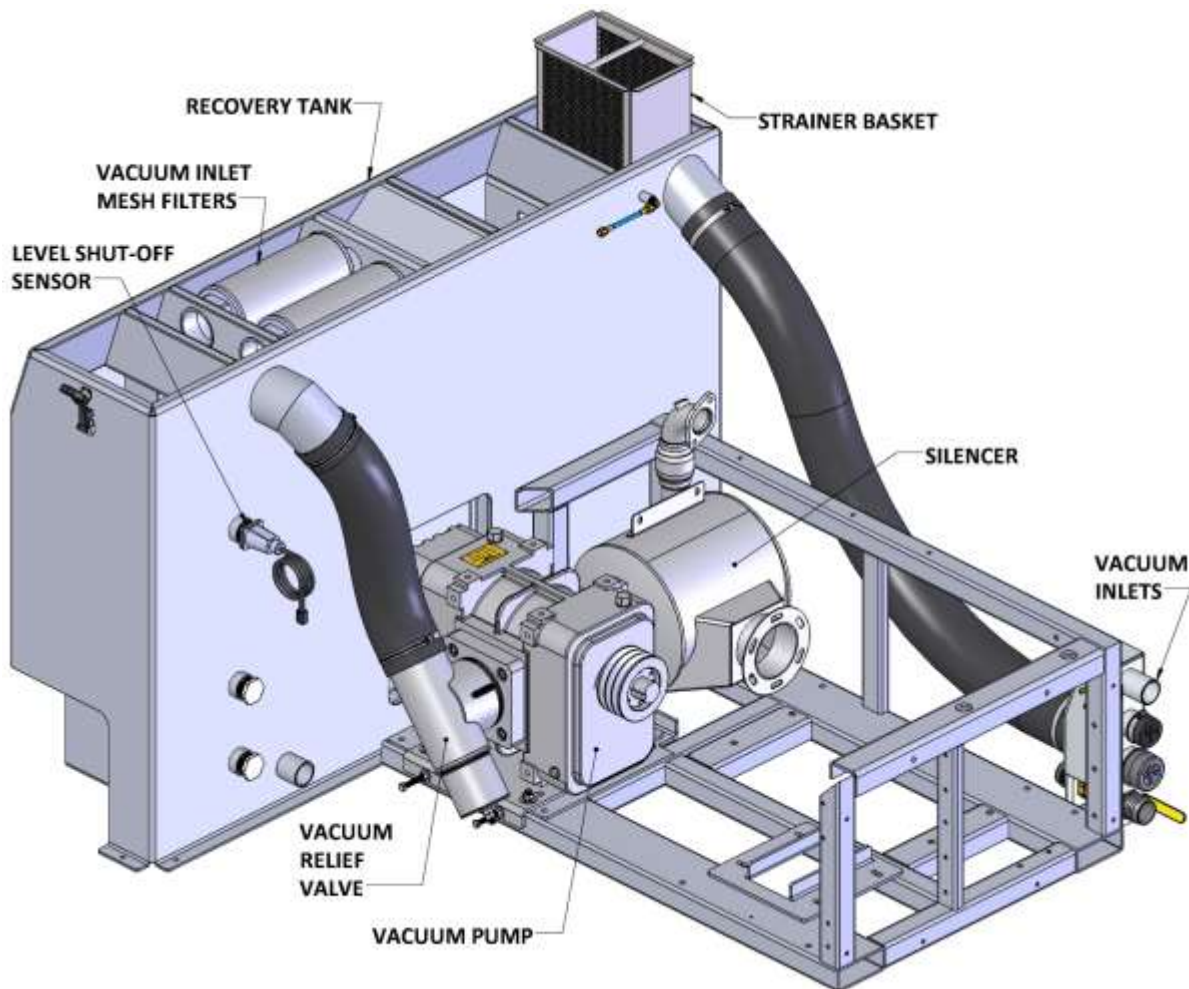

 **CAUTION**

Do not alter the vacuum speed outside the recommended range shown in this manual. Doing so can result in severe damage to the unit and voidance of warranty.

 **CAUTION**

Recovery tank level shut-off will not detect high foam levels. Foam entering the vacuum pump can cause damage to the unit. The use of a quality defoamer is recommended.

**IN ACCORDANCE WITH EPA, STATE AND LOCAL LAWS, DO NOT DISPOSE OF WASTE WATER INTO GUTTERS, STORM DRAINS, STREAMS, RESERVOIRS OR ANY NON-COMPLIANT RECEPTICLE.**

Always check local laws and regulations regarding “gray” water disposal. The penalties for non-compliance can be serious.

## **CHEMICAL PUMPING SYSTEM**

The chemicals are drawn from the chemical container through a strainer into the flow meter mounted on the control panel. The flow meter indicates the rate of chemical flow.

The chemicals then flow through the stainless steel chemical pump, the chemical is then injected into a three way selector valve located on the front panel. This valve may be used to turn the chemical flow **ON**, **OFF**, or to **PRIME** the chemical pump.

The chemicals then flow through the chemical metering valve to the solution outlet. This valve controls the rate of flow of chemical into the cleaning solution, which is indicated on the flow meter.

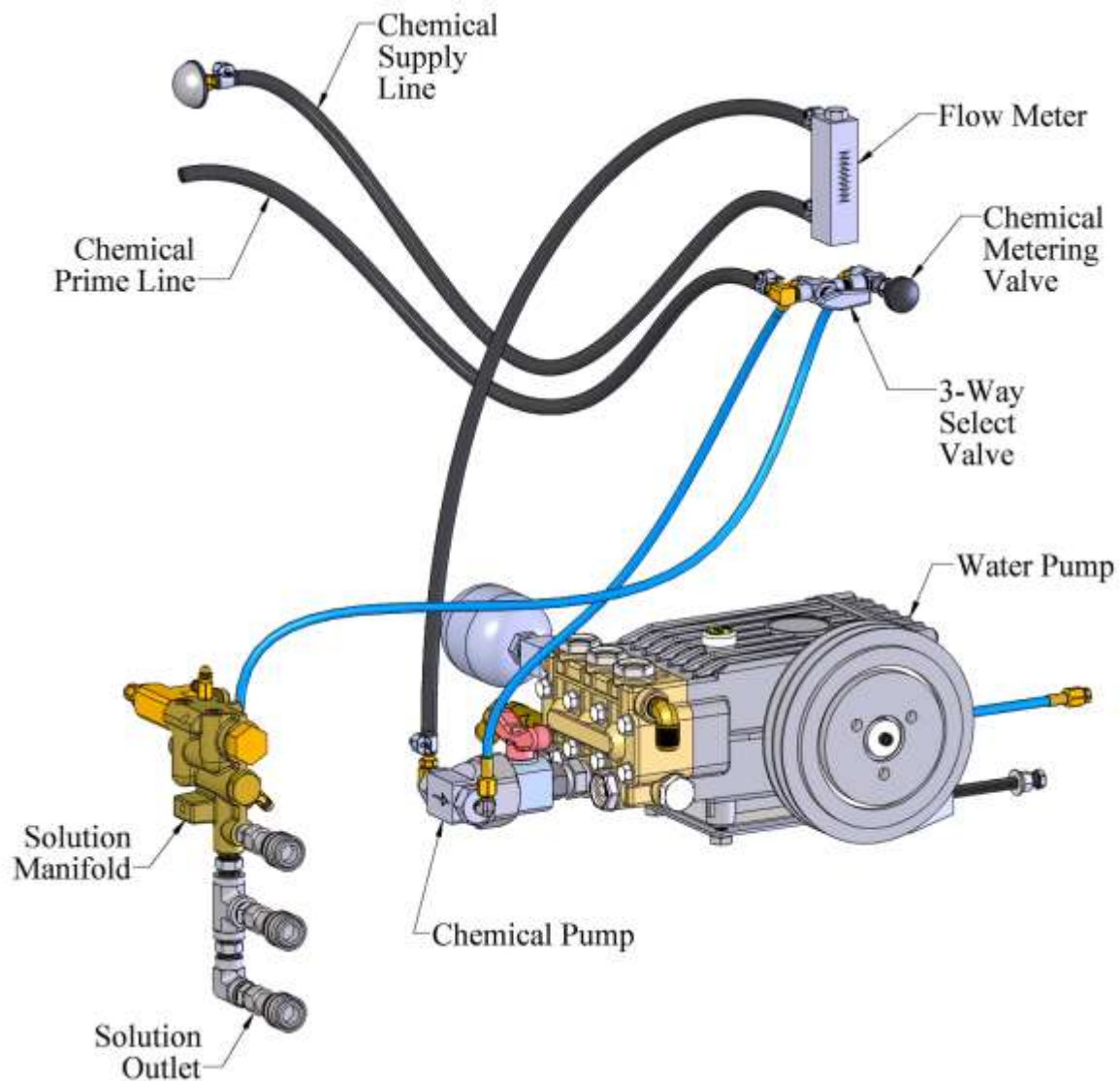

## OPERATION

This section of the operator's manual explains how to prepare, start, operate, shut down and maintain your **870H** direct-drive cleaning unit. The **870H** unit is easy to operate, however only trained operators should proceed.

 **WARNING** Operate this unit and equipment only in a well-ventilated area. Exhaust fumes contain carbon monoxide, which is an odorless and deadly poison that can cause severe injury or death. DO NOT run this unit in an enclosed area. DO NOT operate this unit where the exhaust may enter a building doorway, window, vent or any other opening.

 **CAUTION**  
Do not operate machine with covers or guards removed.

 **CAUTION**  
NEVER operate the unit with the recovery tank air filter removed, damaged or not properly installed.

## UNDERSTANDING THE INSTRUMENT PANEL

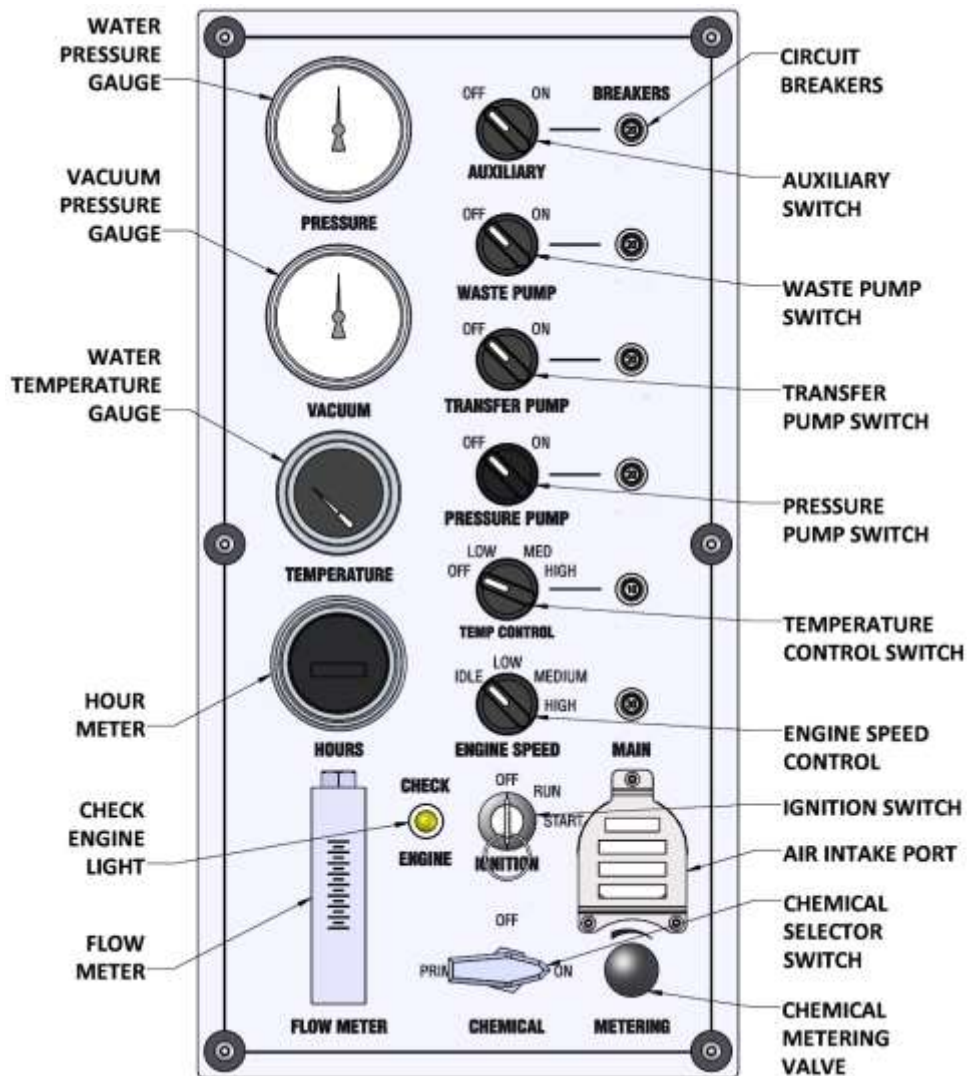

### **WATER PRESSURE GAUGE**

The water pressure gauge will display the water pressure based on how high or low it is set by the pressure regulator.

### **VACUUM PRESSURE GAUGE**

With the unit running, the vacuum gauge should read near zero with vacuum hoses disconnected from the vacuum inlets. If the gauge shows a reading, check the mesh filter and strainer basket in the recovery tank for debris. With vacuum ports sealed, and machine running at high speed, the vacuum gauge should read 11 to 13 inches of mercury (in. Hg). This is preset for the maximum safe operation.



**DO NOT** exceed 13 in. Hg vacuum pressure. This can cause damage to the vacuum pump.



## SECTION THREE – OPERATION

### **WATER TEMPERATURE GAUGE**

The temperature gauge displays the temperature of the water as it leaves the main heat exchanger, just before entering the solution manifold.

### **HOUR METER**

The hour meter records the operating time of the machine. This information is used to calculate maintenance and service intervals. See the Service And Maintenance section in this manual for more information.

### **FLOW METER**

The chemical flow meter

### **CIRCUIT BREAKERS**

Main and auxiliary circuit breakers.

### **AUXILIARY SWITCH**

The auxiliary switch is used to control an auxiliary accessory item, if added, such as a motorized hose reel. Settings are ON or OFF. Auxiliary items can be added to your system at any time.

### **WASTE PUMP SWITCH**

The pump out switch is used to turn a waste pump ON or OFF. Sapphire Scientific part number **68-158** is an optional accessory that can be added to your system at any time.



**68-158, ASSEMBLY, WASTE PUMP OUT**

### **TRANSFER PUMP SWITCH**

If you have an onboard fresh water supply, the transfer pump switch is used to turn the transfer pump ON or OFF for your water supply. This is an optional accessory that can be added to your system at any time.

### **PRESSURE PUMP SWITCH**

The pressure pump switch turns the pressure pump ON or OFF.

### TEMPERATURE CONTROL SWITCH

The temperature control switch provides multiple pre-set temperature settings of OFF, LOW, MEDIUM and HIGH. The OFF setting allows for continual heat diversion, providing no additional heat to the water through the heat exchanger. The LOW setting maintains 185° F water temperature, MEDIUM maintains 200° F water temperature, while HIGH will maintain 240° F water temperature, all at the HIGH engine speed.

### ENGINE SPEED CONTROL

The engine speed control provides multiple preset RPM speeds for engine performance.

### IGNITION SWITCH

The engine ignition switch provides ignition to start the engine when the key is inserted and turned.

### CHEMICAL SELECTOR SWITCH

The chemical selector switch allows you to start, stop or prime the chemical flow.

### CHEMICAL METERING VALVE

The chemical metering valve allows you to control the amount of chemical flow being injected into the cleaning solution.

## UNDERSTANDING THE LOWER PANEL

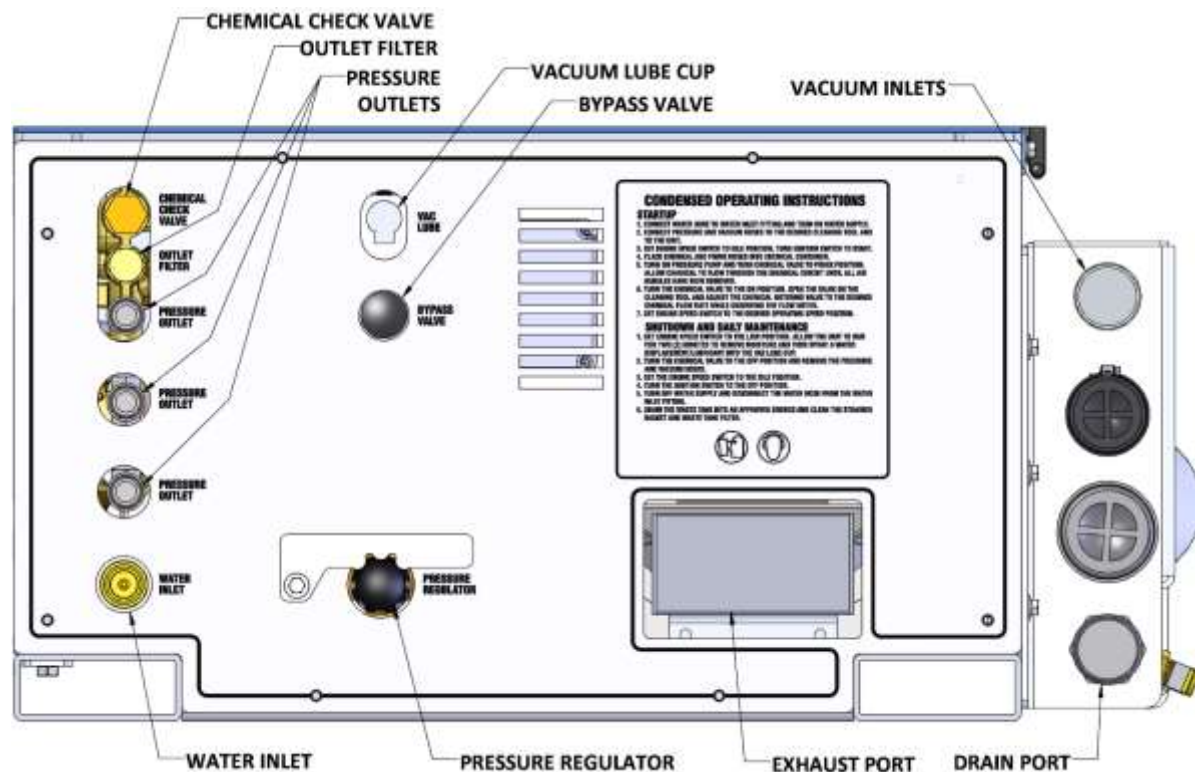

## SECTION THREE – OPERATION

### **CHEMICAL CHECK VALVE**

The chemical check valve allows the chemical injection into the water stream to form the cleaning solution. This is accessible on the front panel for maintenance and service.

### **OUTLET FILTER**

The outlet filter catches debris in the solution stream before it exits the unit for the cleaning tool.

### **PRESSURE OUTLETS**

The pressure outlet is where you connect your solution hose. The 870H has 3 outlets for 3 separate solution hoses.

### **WATER SUPPLY INLET**

The water supply inlet is where you connect your fresh water supply hose.

### **VAC LUBE CUP**

The vacuum relief valve lubrication port is used to deliver lubrication to the vacuum pump. This prevents rust from building up inside the pump.

### **VACUUM INLETS**

The vacuum inlets are where you connect your vacuum hoses. The 870H has two 2 inch and one 2-1/2 inch ports. Always cap unused ports to maintain proper vacuum levels.

### **DRAIN PORT**

The drain port allows a 2 inch hose to be connected for manually draining the recovery tank.

### **EXHAUST PORT**

The exhaust port emits hot exhaust created by the engine and vacuum pump combined.



**Operate your equipment in a well-ventilated area.**

Exhaust fumes contain carbon monoxide, which is an odorless and deadly poison that can cause severe injury or death. DO NOT run this equipment in an enclosed area. DO NOT operate this unit where the exhaust may enter a building doorway, window, vent or other opening.

## **PREPARATION**

### **ENSURE THERE IS ADEQUATE FUEL**

Check the vehicle fuel level to ensure there is adequate fuel to complete the job and transport the vehicle.

### **CHECK YOUR DRAIN VALVES**

Make sure the recovery tank and pre-filter box drains are closed.

### **CHECK FILTERS**

Inspect the vacuum inlet filter and strainer basket in the recovery tank. See the Shut Down and Daily Maintenance section below for more information.

### **ENSURE THERE IS ADEQUATE FUEL**

Check the fuel level to ensure there is adequate fuel to complete the job and transport the vehicle. This unit consumes approximately 2 US gallons of fuel per hour, depending on the speed setting.

### **REMOVE TOOLS FROM THE VEHICLE**

Remove any tools, accessories or hoses from the vehicle that you will require.

### **WATER SUPPLY CONNECTION**

1. Prior to connecting your water inlet hose to any supply faucet, flush out the faucet until the water is free of any debris. Also, flush out any debris from your water inlet hose.
2. Connect the water supply hose to the water inlet quick connector on the front of the unit. Connect the hose to the faucet.
3. Turn the water supply faucet on. Water will fill the water box

**NOTE:** Never use a waste pump outlet hose as a water inlet hose. Use only clean hoses for water supply.

### **HIGH PRESSURE HOSE**

Before starting the unit, connect the high pressure hose to the solution outlet connection at the front of the unit. Connect the cleaning tool to the opposite end of the pressure hose

## **STARTING THE UNIT**

### **STARTING THE ENGINE**



1. Turn on key switch for 2 seconds to build fuel pressure.
2. Turn the key switch to start position.
3. Turn the pressure pump switch to the **ON** position.

**NOTE:** If the unit does not build water pressure after 5 seconds, turn the pressure pump switch to the **OFF** position and check for an adequate water supply.

### **CONNECT THE VACUUM HOSE**

Connect the vacuum hose(s) to the vacuum inlet connection(s) at the front of the console. Connect the opposite end of the vacuum hose to an extraction tool. Make sure that any ports you are not using are capped.

Let the unit run for a few minutes with the vacuum inlets partially blocked off to warm up the cleaning solution.

## **PRIMING THE CHEMICAL PUMP**

**NOTE:** Sapphire Scientific recommends that the chemical pump be primed whenever the pressure pump is on. This eliminates possible pressure fluctuations and pressure pump pulsations related with running the chemical pump dry.

1. Insert the chemical prime tube and the chemical inlet tube into the chemical container.  
**NOTE:** When inserting the chemical tube into the chemical container, ensure that it stays submerged, as the chemical pump will not function if air is allowed to enter the inlet line.
2. Turn the 3-way chemical selector valve located on the control panel to the **PRIME** position. The chemical will then flow from the chemical container through the chemical prime tube into the vacuum system

**If the pump does NOT prime, then:**

3. Seal off the vacuum port. The vacuum will quickly draw chemical from the chemical container. After the flow begins, turn the chemical selector valve to **OFF** position and turn the chemical selector valve back to the **PRIME** position and continue the procedure.
4. When the chemical flows with no air bubbles, priming has been achieved. Turn the chemical selector valve from **PRIME** to **METER**. With the cleaning tool open, check the flow meter and adjust the chemical metering valve until the desired rate of chemical flow is achieved.



**WARNING**  
The chemical pump valve must be closed when operating at a pressure above 1500 PSI to avoid damage to the diaphragm.

### **AUTOMATIC WASTE PUMP**

If your unit is equipped with an optional automatic waste pump:

1. Connect one end of the ½ in. or larger garden hose to the pump-out connection and the other end to an acceptable waste disposal.
2. Turn the pump-out switch located on the front console instrument panel to the **ON** position. The waste pump will now operate automatically throughout the cleaning period.

**DO NOT** use an outlet hose that is smaller than ½ in. I.D.

**NEVER** use a waste pump hose as a water inlet hose.



**WARNING!**  
**NEVER** dispose of waste water in a storm drain, water way or on ground areas. Always dispose of waste in accordance with Local, State and Federal laws.

### **OPERATING THE UNIT**

After you have completed the previous steps, proceed with the cleaning or restoration operation. Place the engine speed control to low speed and after warm up select appropriate speed for desired cleaning or restoration. A float shut-off switch is located inside of the recovery tank. It will automatically shut down the unit if the tank reaches its full capacity. If this occurs, drain the waste tank before continuing. When doing flood extraction, the pressure pump should be in the **OFF** position.

**NOTE:** Vacuum pressure must have a minimum 7”Hg for the diverter valve to work properly. Attaching 1 length of hose should create enough vacuum pressure to achieve this.

### **CLEANING**

1. Before cleaning, ensure that the wand nozzles are functioning properly.
  - a. Hold the wand approximately one foot above the surface to be cleaned and open the wand valve. A full even spray should emit from the cleaning nozzles.
  - b. If the nozzles are not showing a full even spray pattern, adjust, clean, or replace the nozzles, if required.

## UPHOLSTERY CLEANING

Run unit on low speed. Upholstery tools have a lower flow rate and smaller orifices. Switch the temperature control to the desired temperature range. To maintain proper cleaning temperatures, make certain that the unit has been fully heated up prior to cleaning

## STAIR TOOL CLEANING

Run unit on low speed. Switch the temperature control to the desired temperature range.

## FLOOD RESTORATION/EXTRACTION



**Make certain that the pressure pump switch is in the OFF position.**

Set the throttle control to desired speed. Proceed into the extraction process.

## **SHUT DOWN AND DAILY MAINTENANCE**

1. Flush out the chemical system with fresh water to remove any chemical residue.
2. Remove as much moisture from the vacuum hoses as possible. This will prevent spilling of waste water when recoiling the hoses onto the reel.
3. Disconnect the vacuum hoses from the unit, leaving the vacuum port(s) open.
4. Switch the temperature control to the lowest setting.
5. Allow the unit to run for 2 to 3 minutes with the bypass valve open. This will cool down the unit and help to remove any excess moisture from the vacuum pump.

**NOTE: If shutting down for the day** – plug the vacuum inlet(s) and set the set the engine speed to **MEDIUM**. Spray a water displacement/lubricant (i.e. WD-40) into the vacuum lubrication cup located on the lower front panel for 5 to 10 seconds. Run the unit for 2 minutes to lubricate the vacuum pump. Unplug the vacuum inlet and return the engine speed to the **IDLE** position.

**NOTE: If you are using an onboard water supply**, re-pressurize the system before fully shutting down for the day.

6. If plugged, unplug the vacuum inlet port, relieving load and make sure the engine speed control is set in the **IDLE** position.
7. Turn the ignition switch to the OFF position to shut down the engine.

## SECTION THREE – OPERATION

8. Turn the water supply faucet off. Loosen the water supply hose at the water supply to bleed off any pressure. Unhook the water supply hose and return it to the vehicle.
9. Activate the valves on all cleaning tools to relieve pressure. Disconnect the tools and solution hoses and return them to the vehicle.
10. Make sure the recovery tank is completely drained into an approved source.

### **WARNING**

**NEVER dispose of waste water in a storm drain, water way or on ground areas. Always dispose of waste in accordance with Local, State, and Federal laws.**

11. Remove the strainer basket from the recovery tank and clean thoroughly before replacing. Microban QGC cleaner is the best product for cleaning and sanitizing the recovery tank.
12. Check the mesh vacuum inlet filter inside the recovery tank for debris. Replace if damaged.

**NOTE:** To remove the vacuum inlet filter, grip the plastic hexagon section of the filter. Gripping the filter by the screen will collapse or destroy the filter. After cleaning, grease the threads on the filter and replace the filter. Tighten the filter until hand tight and then loosen  $\frac{1}{4}$  turn. This will make the filter easier to remove when cleaning or replacement is required.

### **CAUTION**

**NEVER operate this unit with the filter removed, damaged or improperly installed.**

At the end of the work day, rinse out the recovery tank with fresh water.

Clean the unit, tools, hoses etc., as needed. Inspect **ALL** equipment and accessories for any damage, leaks, wear, etc.

## **AUTOMATIC SHUT DOWNS**

When the recovery tank is full, the engine will shut down. If this happens, make sure the PUMP OUT switch is in the OFF position and empty the recovery tank into an approved source to resume operation.



## FREEZE PROTECTION

### WINTERIZING YOUR UNIT

#### CAUTION

If the unit is exposed to freezing weather conditions, the water inside of the unit may freeze, resulting in **SERIOUS DAMAGE** to components. Water freezes at 32° F and 0° C. The following is recommended to prevent this from occurring during the cold weather season:

If possible, store the unit in a heated building when not in use.

While in operation, avoid long periods of shut-down as the unit generates heat while running. Keep the unit running just prior to leaving for the next job.

If a heated storage is not available, winterize the unit with antifreeze. It is **NOT** possible to winterize units that have auxiliary water tanks. They must be stored in a heated building.

### **WINTERIZING THE UNIT WITH ANTIFREEZE**

- A. Shut off the water supply to the unit and disconnect the water inlet hose from the console.
- B. Run the unit on low with an open-ended hose connected to one of the solution outlets to dispose of as much water as possible. Turn the unit off.
- C. Connect a winterizing hose loop (one can be purchased from Sapphire Scientific – part number 68-168) from the water inlet to any one of the pressure outlets.

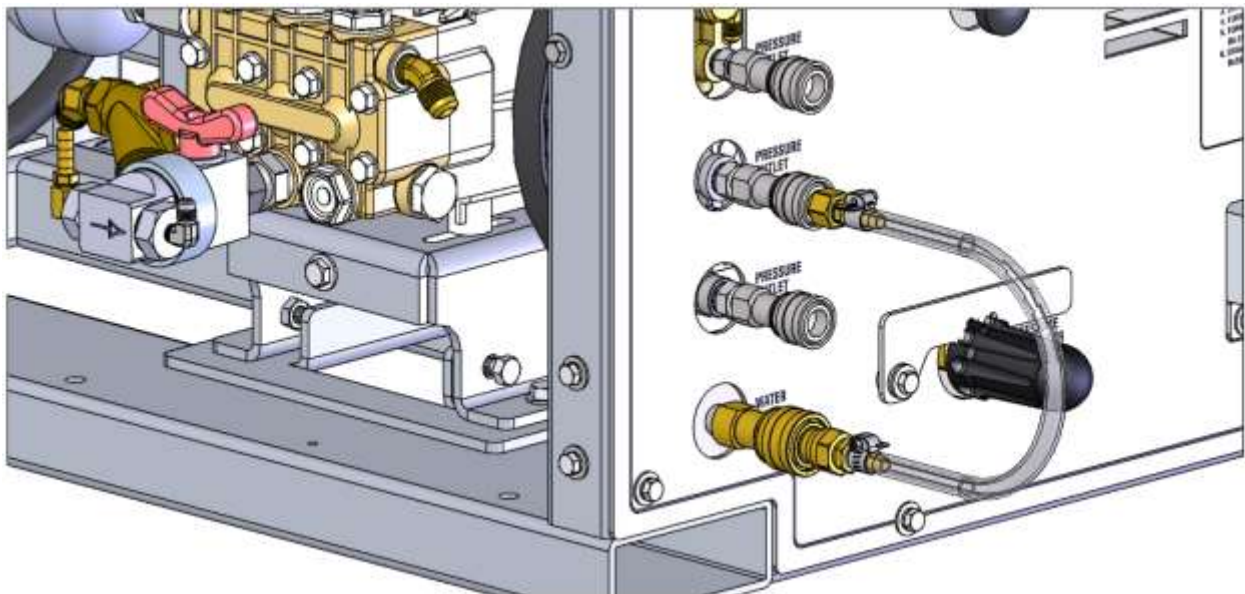

## SECTION THREE – OPERATION

- D. Fill the water box with one gallon of 100% glycol based antifreeze.
- E. Turn the pressure regulator all the way down. Start the unit on IDLE and turn the pressure pump switch to the ON position to run coolant through the system.
- F. Allow the unit to run for 3 minutes to fully circulate the antifreeze.
- G. With the unit still running, prime the chemical injection system with 100% glycol based antifreeze. Insert the chemical inlet and prime tubes into the antifreeze container. Turn the chemical selector switch to PRIME until antifreeze comes out of the prime hose. Turn the chemical selector switch to the ON position. Ensure the flow meter indicates flow.
- H. After 25 seconds, turn the chemical selector switch to the OFF position.
- I. Disconnect the winterizing hose loop and allow the unit to run for another minute to fully circulate through the bypass cooler.
- J. Turn the pressure pump switch to the OFF position and turn the ignition switch to the OFF position to turn off your unit.

### **WINTERIZING HOSES AND TOOLS WITH ANTIFREEZE**

- A. After winterizing your unit, remove the winterizing hose loop and connect all your hoses and tools to the solution outlet ports. Make sure the tool(s) can drain into an approved antifreeze container.
- B. Make sure the pressure regulator is turned all the way down. Start the unit on IDLE and turn the pressure pump to the ON position.
- C. Open a tool valve until antifreeze begins to flow from the tool. Repeat this with all tools and hoses as necessary.
- D. When completed, turn the pressure pump to the OFF position and turn the ignition switch to the OFF position to shut down the unit.
- E. Disconnect and store the hoses and tools once they have been winterized.

**Recover as much antifreeze as possible and store in an approved container. Always reuse or recycle antifreeze.**

**REMOVING ANTIFREEZE FROM THE UNIT**

- A. Connect all winterized solution hoses and tools to the unit. Start the unit in IDLE. Turn the pressure pump switch to the ON position.
- B. Open a tool valve and ensure that antifreeze goes into an approved container. Allow antifreeze to flow into the container until it has all been drained.
- C. Fill the water box with fresh water and repeat steps A and B.
- D. Connect the water inlet hose to the unit and turn the water supply on. Open all tool valves and drain the remaining antifreeze into an approved container until water runs clear and all of the antifreeze is purged from the hoses and tools.
- E. Insert the chemical prime hose into an approved container. Submerge the chemical supply hose into fresh water. Turn the chemical selector valve to PRIME until water runs clear through the prime hose. Remove the prime hose from the container.
- F. Turn the chemical selector switch to the ON position and open attached tool valves. This will allow water to flow to the other side of the system.
- G. After all the antifreeze has been removed, the unit is ready to operate.
- H. The antifreeze container will eventually become diluted with water. When the antifreeze level drops below 70% of the total mixture, properly dispose of it and start over fresh with 100% antifreeze.

## SECTION FOUR: SERVICE AND MAINTENANCE

### MAINTENANCE CHART

DAILY, WEEKLY AND MONTHLY MAINTENANCE CHARTS.....	41
---	----

### SERVICE CHART

SERVICE INTERVAL CHARTS.....	42
------------------------------	----

### MAINTENANCE

ENGINE.....	44
DRIVE BELTS, PULLEYS AND HUBS .....	45
VACUUM PUMP .....	46
PRESSURE PUMP .....	47
CHEMICAL PUMP .....	47
CHEMICAL METERING SYSTEM .....	47
CHECK VALVE STRAINER .....	47
BATTERY .....	48
RECOVERY TANK STRAINER BASKET .....	48
VACUUM INLET FILTER.....	48
VACUUM HOSES.....	49
HIGH PRESSURE SOLUTION HOSES .....	49

### GENERAL SERVICE ADJUSTMENTS

VACUUM RELIEF VALVE .....	50
WATER PUMP DRIVE BELT .....	50
SOLUTION OUTLET CHECK VALVE .....	51
CHEMICAL PUMP .....	52
PACKING NUT ADJUSTMENT – CHEMICAL METERING/SELECTOR VALVES .....	53
PRESSURE REGULATOR .....	53
WYE STRAINER .....	55
INLET PRESSURE REGULATOR.....	55

### TROUBLESHOOTING

ENGINE.....	57
VACUUM PUMP .....	58
HEAT EXCHANGER/TEMPERATURE RELATED .....	58
PRESSURE PUMP .....	59
CHEMICAL SYSTEM.....	60
WASTE PUMP (OPTIONAL ACCESSORY).....	61

## OPERATOR MAINTENANCE CHART

### DAILY MAINTENANCE

Engine	Check engine oil level. (1) Fill to proper level. Do not overfill.
Vacuum Pump	Check vacuum pump oil level. Fill to proper level. Do not overfill. (2)
Vacuum Pump	Spray WD-40 (or Equivalent) into the lubrication cup for 10 seconds.
Vacuum Inlet Filter	Inspect filter, clean and or replace. (2)
Pressure Pump	Check pressure pump oil level. (3) Fill to proper level.
Strainer Baskets	Empty and clean stainless steel baskets in the recovery tank and filter box
Recovery Tank	Rinse tank and clean.
Vacuum Hoses	Rinse with fresh water. (2)
Waste Pump (optional)	Inspect and remove any debris or sediment. (2)

### WEEKLY MAINTENANCE

Float Switches	Clean and inspect float switches in the recovery tank.
Visual Inspection	Check for leaks in the equipment.

### MONTHLY MAINTENANCE

Engine	Inspect drive belts for wear. Replace as needed.
Engine	Inspect air cleaner for damaged, dirty or loose parts.
Radiator	Check for debris in the radiator.
Battery	Check fluid level. Fill with distilled water only. Do not overfill.
Battery Terminals	Check vehicle battery terminals. Clean as needed.
Check Valve Strainer	Clean and remove any debris. (4)
Thermal Well	Lubricate diverter shaft with anti-seize.
Wiring Harness	Check wiring throughout for signs of chafing or wear.
Check fasteners	Check fastener tightness on all components. Tighten as needed.

### YEARLY MAINTENANCE

Engine	Replace air filter element.
Check Valve	Check seat for abnormal wear or debris. Replace as needed.

To maximize the operating life and performance, use only recommended oils, filters and greases.

- (1) Change engine oil and oil filter after first **50 hours** of operation.
- (2) Or as often as required.
- (3) Change pressure pump crankcase oil after first 50 hours of operation.
- (4) Inspect after **first week** of operation and remove any debris present. Inspect again after **2 to 4 weeks**.

## DEALER SERVICE CHART

### SERVICE INTERVALS – EVERY 25 HOURS

High Pressure Hoses	Inspect for wear, damage, or impending rupture. Replace if damaged.
---------------------	---

### SERVICE INTERVALS – EVERY 100 HOURS

Vacuum Relief Valve	Check and adjust vacuum relief valve up to 13" Hg if needed.
Belts	Re-tension all belts (2)
Battery	Clean battery terminals
Pressure Regulator	Lubricate o-rings. Use only o-ring lubricant part # 13-003

### SERVICE INTERVALS – EVERY 200 HOURS

Engine	Change engine and oil filter. (1)
Engine	Clean engine air filter.
Chemical Metering System	Inspect packing nut on selector and metering valve. Adjust as needed.

### SERVICE INTERVALS – EVERY 500 HOURS

Engine	Replace inline fuel filter. (3)
Pulleys and Hubs	Check pulleys and hubs for proper torque. (4)
Pressure Pump	Change crankcase oil. (5)
Chemical Pump	Change diaphragm and check valves. Inspect disk.

### SERVICE INTERVALS – EVERY 1000 HOURS

Engine	Replace air filter element.
Vacuum Pump	Drain, flush and replace oil. (6)

### SERVICE INTERVALS – EVERY 2000 HOURS

Belts	<b>Replace ALL belts (including the engine timing belt)</b>
-------	---

To maximize the operating life and performance, use only recommended oils, filters and greases.

- (1) Change engine oil and oil filter after first **50 hours** of operation, then every 200 hours.
- (2) Re-tension belts after **first 25 hours**, then every **100 hours** of operation after.
- (3) Or every 6 months, whichever comes first.
- (4) Check pulley and hub set screws after **first 50 hours** of operation, and again at **100 hours** of operation.
- (5) Change pressure pump crankcase oil after first 50 hours of operation.
- (6) Every **1000 hours** or **yearly**, whichever comes first.

## MAINTENANCE

This section of the operator’s manual contains the service and maintenance information for the 870H unit. A planned preventative maintenance program will ensure that your 870H has optimum performance, long operating life, and a minimum amount of down time.

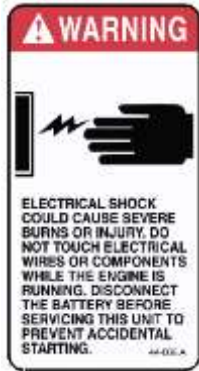

### WARNING

**DO NOT** attempt to service this unit while it is running. High speed parts as well as high temperature components may result in severe injury, severed limbs, or fatality.

**NOTE:** Refer to the hour meter as a guide for coordinating a maintenance schedule.

## **ENGINE**

Use engine oil that is API (American Petroleum Institute) Service Grade Certified, class SG or above. **Do not use additives.**

An SAE viscosity grade is used to specify the viscosity of engine oil. SAE 10W-30 specifies multiple viscosity engine oil. When choosing engine oil, consider the range of temperatures the unit will be operated in before the next oil change. Select engine oil that is best suited to your area’s particular ambient temperature range and variation. Sapphire Scientific recommends using synthetic SAE 10W-30 engine oil.

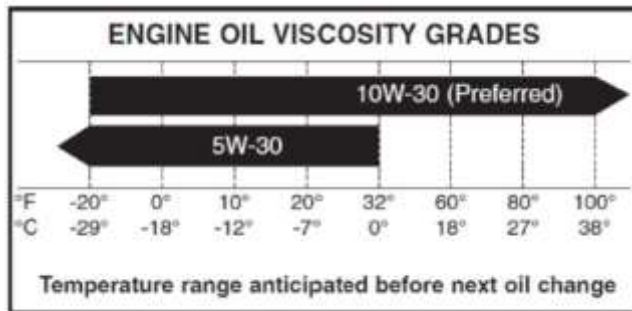

*Temperature/Engine Oil Viscosity*

**NOTE:** Using lower service class oil or extending oil change intervals longer than recommended can cause engine damage.

Engine oil capacity	3.3 L 3.48 U.S. qts
---------------------	------------------------

Tightening torque	Oil Drain Plug	40 – 45 Nm 400 – 450 Kg.cm 30 – 33 lb.ft
	Oil Filter	12 – 16 Nm 120 – 160 Kg.cm 9 – 12 lb.ft

**Check engine oil daily.** Ensure that the proper oil level is maintained. **NEVER** overfill.

**NOTE:** Use only OEM oil filters. Use of any other type of oil filter will void engine warranty.

**NOTE:** Additional engine service information can be obtained from the provided Hyundai Operation and Maintenance manual. If service or repair is required, contact an authorized Hyundai Service Center. They will require the serial number of the engine.



## **DRIVE BELTS, PULLEYS AND HUBS**

Check pulley set screws and hub screws after the first **25 hours** of operation and again at **100 hours**. Re-torque these screws with a torque wrench. Follow the torque values on the following table. Check pulley set screws and hub screws every **500 hours** thereafter.

**NOTE:** Ensure belts are properly tensioned after checking the torque values. Use Gates EPDM belts.



**Ensure that when you re-torque the screws, you use a clockwise pattern and continue until the proper torque is achieved.**

<b>TORQUE VALUES</b>		
<b>Component</b>	<b>Inch/lbs</b>	<b>Foot/lbs</b>
Vacuum Pump Hub #38-032	180	15

## **VACUUM PUMP**

**Lubrication:** Sapphire Scientific *requires* that you use only AEON PD-XD Synthetic vacuum pump Lubricant in both sides of the vacuum pump for all operating temperatures. AEON PD-XD is formulated specifically for positive displacement vacuum pump service to provide maximum vacuum pump protection at any temperature.

**NOTE:** AEON PD-XD (Part # 13-004) is the only oil that Sapphire Scientific puts in the vacuum pump at the factory. Adding petroleum oil to synthetic oil is **NOT** recommended.

Check the oil level **daily** on both sides to ensure they are at the proper level. Too little oil will damage and ruin the bearings and gears. Too much oil will result in overheating.

**NOTE:** Two drains are on your vacuum pump. Ensure that **BOTH** sides of the vacuum pump are filled to their proper level when servicing.

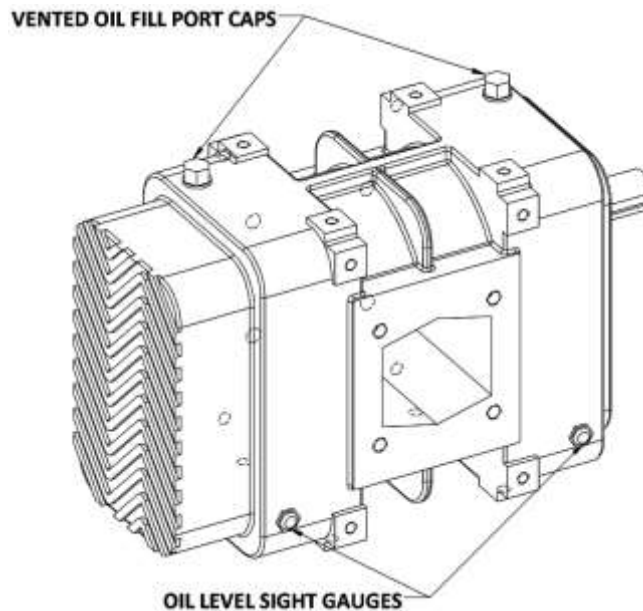

A lubrication cup has been provided at the front of the console, to prevent rust from building up inside of the vacuum pump.

Plug the vacuum ports and spray a water displacement/lubricant into the vacuum lubrication cup for 5 to 10 seconds. This procedure should be done at the end of **every working day**.

Drain, flush and replace the oil every **1000 hours or yearly**, whichever comes first.

## **PRESSURE PUMP**

Check the crankcase oil level daily to ensure the proper level. If the level has dropped, check for the source of leakage and repair.

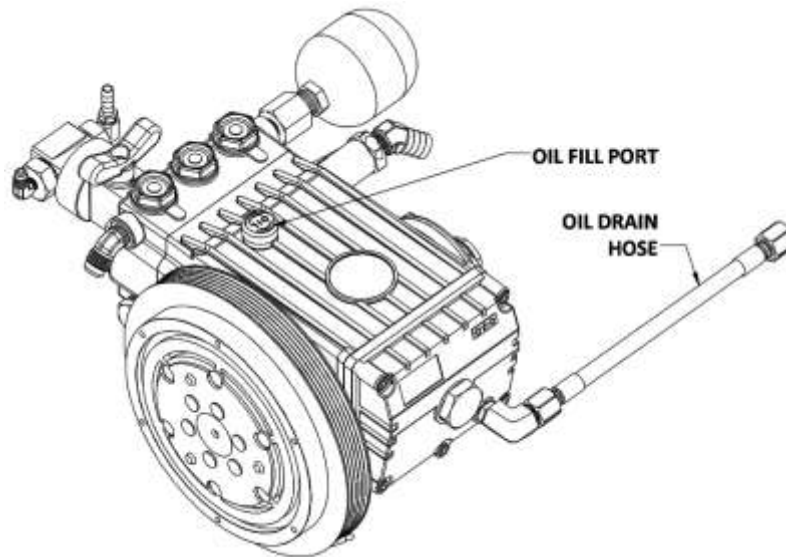

Change the crankcase oil after the first 50 hours of operation with General Pump Oil (Sapphire Scientific part number 13-030). Change the crankcase oil every 500 hours thereafter. Oil capacity is 40.6 oz.

## **CHEMICAL PUMP**

The chemical pump should be rebuilt every 500 hours. This involves changing the diaphragm, check valves, and inspecting the disk. DO NOT attempt to reuse o-rings after the check valves have been removed. Replace all o-rings when servicing check valves.

## **CHEMICAL METERING SYSTEM**

Check and inspect the packing nut on the chemical selector and metering valves every 200 hours. Keeping the valve packing's properly adjusted will prevent leaks and add to the overall life of the valves.

## **CHECK VALVE STRAINER (OUTLET)**

Unscrew the screen and inspect the strainer after the first week of operation. Remove any debris present. Inspect again after 2 and 4 weeks. Thereafter, inspect the strainer and screen at least monthly. If a frequent build-up of debris is noticed, inspect and clean more frequently.

## **BATTERY**



**Explosive gases, Dangerous acid!**

**Batteries contain sulfuric acid. To prevent acid burns, avoid contact with skin, eyes and clothing. Batteries also produce explosive hydrogen gases while charging. To prevent fire or explosion, charge batteries only in a well ventilated area. Keep sparks, open flames, as well as any other sources of ignition away from batteries at all times. Remove all jewelry prior to servicing batteries. Keep batteries out of the reach of children.**

Before disconnecting the negative (-) ground cable, ensure that all switches are in the OFF position. If ON a spark could occur at the ground connection terminal, which could cause an explosion if hydrogen gas or gasoline vapors are present. ALWAYS disconnect the negative (-) terminal first.

- If you do not have a maintenance free sealed battery, check the fluid level in the battery at least once a week. If low, fill to the recommended level ONLY with distilled water. DO NOT overfill the battery. Early failure or poor performance will result due to loss of electrolyte.
- Keep cables, terminals and external surfaces of the battery clean and dry. A buildup of corrosive acid or grime on the external surfaces could cause the battery to self-discharge.
- Battery terminals should be cleaned every 100 hours to prevent corrosion buildup. Wash the cables, terminals and external surfaces with a mild baking soda and water solution. Rinse thoroughly with fresh water. DO NOT allow baking soda to enter the battery cells, as this will destroy the electrolyte, resulting in battery failure.

## **RECOVERY TANK STRAINER BASKET**

The recovery tank strainer should be emptied and cleaned on a **daily** basis.

## **VACUUM INLET FILTER**

The vacuum inlet filter in the recovery tank should be inspected and cleaned **daily**.



When removing the vacuum inlet filter, grip the plastic hexagon section of the filter. Grasping filter by the screen will damage or destroy the filter. Applying grease to the threads will allow easier removal of filter when cleaning or replacement is required.

## **VACUUM HOSES**

To ensure maximum hose life, Sapphire Scientific recommends that you wash out the hoses with fresh water **daily**.

## **HIGH PRESSURE SOLUTION HOSES**

Inspect your high-pressure solution hoses for wear after the first 100 hours. Thereafter, inspect every 25 hours. If the hoses show any signs of damage or impending rupture, replace the hoses.



**NEVER attempt to repair high-pressure solution hoses. Repairing high-pressure solution hoses may result in severe burns and serious injury.**

**All high-pressure solution hoses must be rated for 3000 PSI at 250 deg. F. Thermoplastic hoses do not meet this requirement and should not be used. Severe burns and injury may result if the hoses do not meet these requirements.**

## GENERAL SERVICE ADJUSTMENTS

### **WARNING**

**DO NOT attempt to service this unit while it is running. High speed parts as well as high temperature components may result in severe injury, severed limbs, or fatality.**

### **VACUUM RELIEF VALVE**

With the unit running at high speed, block off the airflow at the vacuum inlet port and read the vacuum gauge. If adjustment is required, shut the unit down and adjust the locking nut tension on the vacuum relief valve. Re-start the unit and read the vacuum gauge. Repeat this process until the vacuum relief valve opens at 13" Hg. Always ensure the lock nut is retightened and the cotter pin is replaced.

### **WARNING**

**To reduce the risk of injury: NEVER obstruct the vacuum port with your hand or other body part. Keep hair, loose clothing and all body parts away from vacuum port openings while unit is in operation.**

### **WATER PUMP DRIVE BELT**

To tighten the water pump belt:

1. Loosen the four bolts, which hold the water pump base to the frame.
2. Adjust the position of the belt tensioning adjusting bolt until the proper belt tension is achieved (1/2" deflection in the center of the belts, half way between the pulleys). Do not over-tighten; damage to pump may occur.
3. While checking the alignment, tighten the nuts that hold the water pump to the base.

### **CAUTION**

**Over tightening of belts may cause damage to pump components and engine crankshaft, causing them to fail.**

**SOLUTION OUTLET CHECK VALVE**

Inspect the check valve whenever performing service on the chemical pump or if flow problems are occurring in the chemical system.

1. Shut down Unit.
2. Remove the check valve, ensuring that the small o-ring on the seat comes out with it
3. Next, remove the seat using a 5/16 in. Allen wrench
4. Check the Teflon seat for wear or debris. Clean and replace the seat if necessary.
5. Inspect the poppet and the spring for wear or damage. Clean and replace as necessary.

**NOTE:** New o-rings must be installed anytime the check valve is removed.

6. Re-assemble the check valve. Thread the seat by hand until snug. Then tighten with a 5/16 in Allen wrench. **DO NOT** over-tighten.

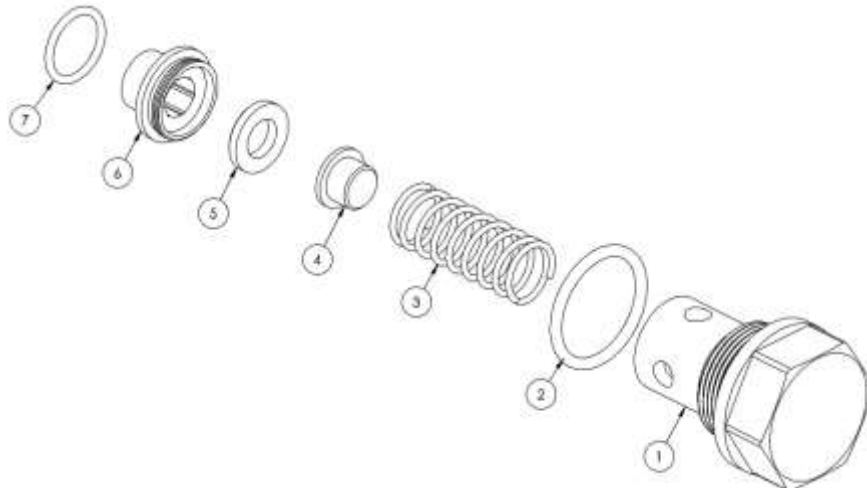

1	7	41-008	ORING, .5 ID X .625 OD
1	6	27-011	SEAT, CHECK VALVE
1	5	27-004	INSERT, SEAT CHECK VALVE
1	4	27-010	POPPET, CHECK VALVE
1	3	15-007	SPRING, CHECK VALVE
1	2	41-007	ORING, .875 ID X 1.0625 OD
1	1	66-282	CAP, CHECK VALVE
QTY	ITEM	PART NO.	DESCRIPTION

**NOTE:** Improper seating of the check valve seat, poppet, damaged spring or o-rings will result in poor performance of the chemical system.

7. Lubricate the new o-rings with o-ring lubricant (Sapphire Scientific part # 13-003) and re-install.

## CHEMICAL PUMP

The 870H features a stainless steel chemical pump and metering system. The chemical pump requires only the replacement of the diaphragm plastic disc and check valves. To replace the diaphragm, unscrew the cover from the body. When replacing the diaphragm, lube the outer edges of the diaphragm with o-ring lubricant (Sapphire Scientific part #13-003) and reassemble.

To replace the check valves, remove the check valve caps, replace the check valves and reassemble using new o-rings. **DO NOT** attempt to reuse o-rings after the check valves have been removed.

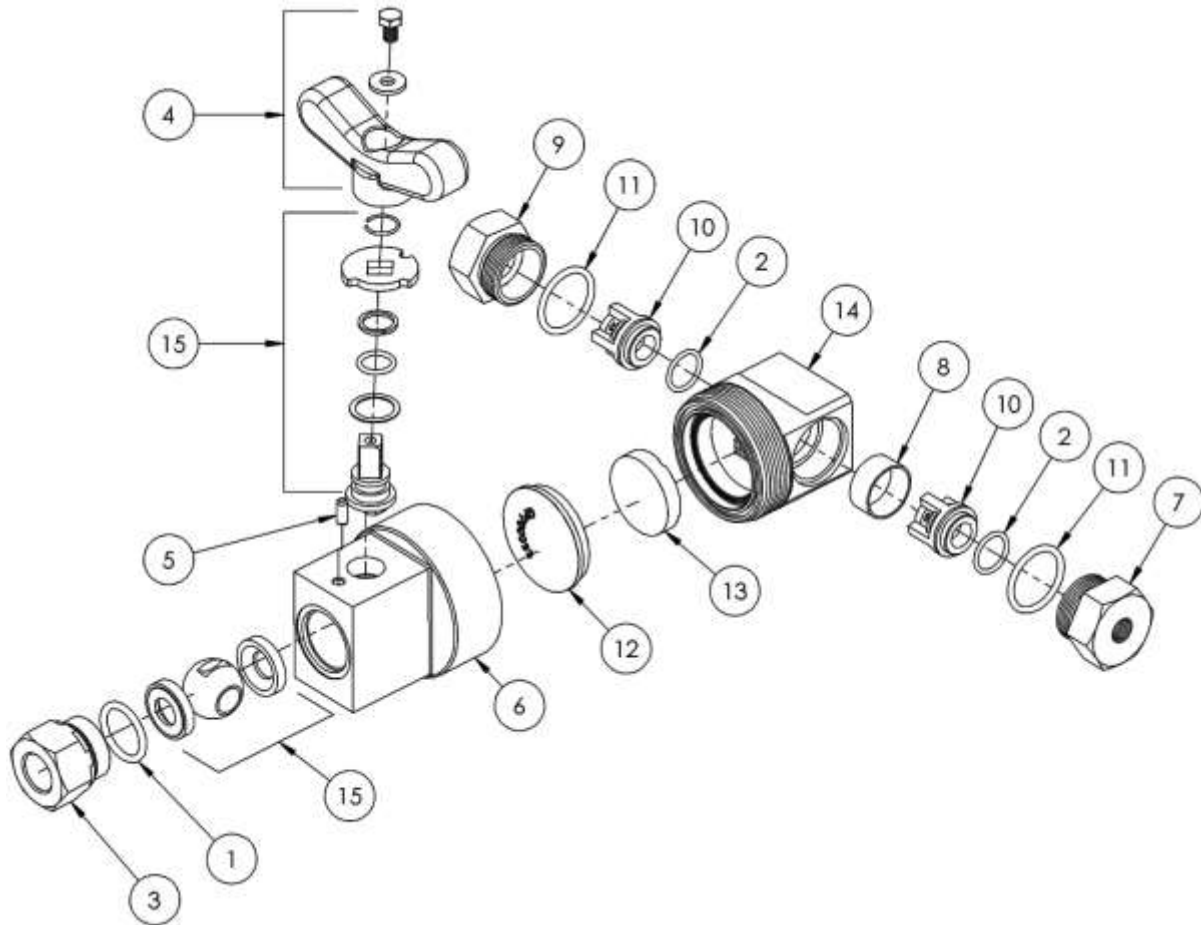

1	14	36-350	BODY, PULSE PUMP, GP PULSE PUMP-1
1	13	36-351	PLASTIC DISC, GP PULSE PUMP-1
1	12	36-352	RUBBER DIAPHRAM, GP PULSE PUMP-1
2	11	36-354	O-RING, 70 DURO, GP PULSE PUMP
2	10	36-355	VALVE CAP 303SST, GP PULSE PUMP-2
1	9	36-356	ASSY, VALVE KIT, GP CHEMICAL PULSE PUMP-1
1	8	36-357	SPACER RING, 303 SST, GP PULSE PUMP-1
1	7	36-358	VALVE CAP, 303 SST, GP PULSE PUMP-1
1	6	36-385	TOP COVER INLET W-VALVE, GP PULSE PUMP-1
1	5	36-387	PIN, ROTATION STOP, GENERAL PUMP W-VALVE-1
1	4	36-388	HANDLE, GENERAL PUMP W-VALVE
1	3	36-389	FITTING, BALL VALVE HOUSING, GENERAL PUMP W-VALVE
2	2	36-390	O-RING, .612 X .103, GP PULSE PUMP
1	1	36-391	O-RING, .757 X .103, GP PULSE PUMP
QTY	ITEM	PART NO.	DESCRIPTION



## **PACKING NUT ADJUSTMENT CHEMICAL METERING/SELECTOR VALVES**

Inspect the packing nut for proper tension on the chemical metering and chemical selector valves every 200 hours. When turning the knob, there should be some resistance. If not, slightly tighten the packing nut. DO NOT over tighten. Keeping the packing properly adjusted will eliminate possible leaks and will add to the overall life of the valves.

### **23-027, CHEMICAL SELECTOR VALVE**

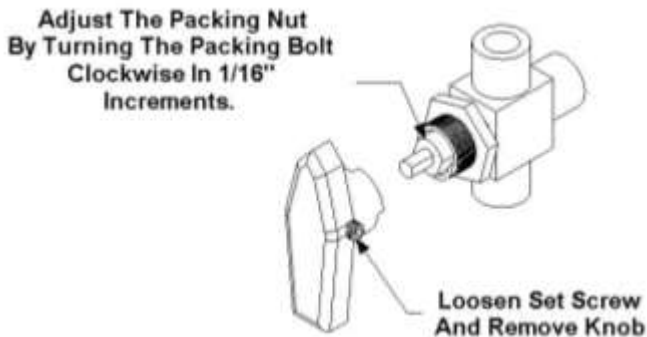

### **23-028, CHEMICAL METERING VALVE**

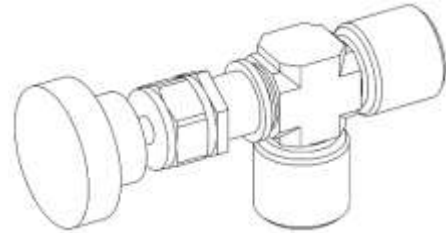

## **PRESSURE REGULATOR**

The pressure regulator holds water pressure at a preset point and bypasses the excess water back to the water box.

### **To adjust:**

1. With the unit running, close the cleaning tool valve. Check the pressure gauge. Open the tool valve. Set the pressure regulator so that the pressure gauge reads 400 - 2500 PSI with the tool valve closed. With the tool valve open, there should be a normal drop in pressure. If the drop is greater than 100 PSI, it may be necessary to lubricate the pressure regulator o-rings.
2. To adjust the pressure regulator, turn the adjusting knob (while observing the pressure gauge on the control panel) until you reach the desired pressure.



**CLOSED POSITION**



**OPEN POSITION**

**⚠ WARNING**

**DO NOT** loosen the adjusting body (cap) all the way (counterclockwise) or remove it while the unit is running.

We recommend that you lubricate the pressure regulator o-rings every 100 hours or whenever required. If you do not, the stem may become seized due to inadequate lubrication. If this occurs:

1. Shutdown the unit. Relieve all pressure from the water system.
2. Remove the cap from the pressure regulator and remove the stem with long nose pliers.
3. Clean and lubricate stem.
4. Reassemble pressure regulator.

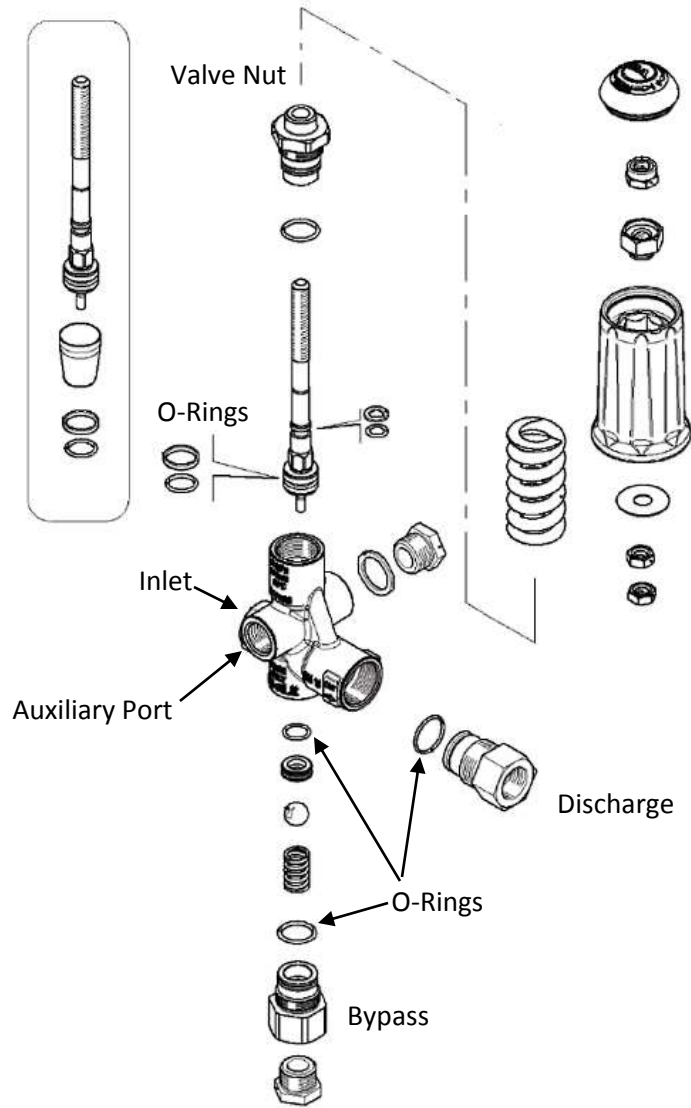

## **WYE STRAINER**

Water heading to the pressure pump from the thermal well passes through a wye strainer stainless steel mesh screen. The wye strainer captures incoming debris and will restrict water flow when clogged. Inspect and clean at least once a month or as needed. Hard water deposits can build and reduce water flow.

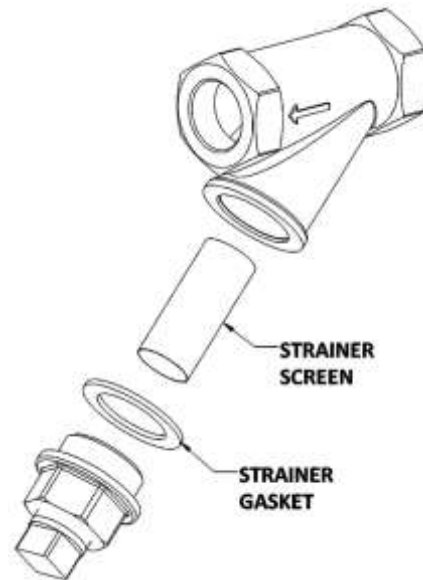

## **INLET PRESSURE REGULATOR**

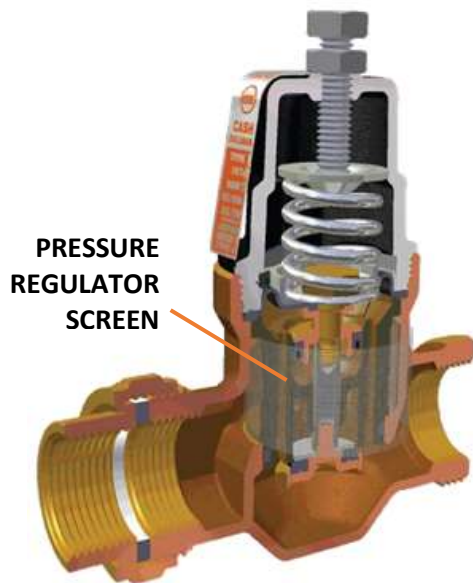

Incoming water immediately passes through a stainless steel mesh screen located inside the inlet pressure regulator. Inspect and clean at least once a month. Hard water deposits can build and reduce water flow.

The inlet pressure regulator comes pre-set at the factory.

If the pressure needs to be reset, connect an incoming water supply line, loosen the locking nut and adjust the bolt on the regulator until the water pressure overrides the reservoir pressure cap and begins to flow from the overflow tube. Loosen the bolt approximately a quarter turn until the water overflow stops. This should be the proper setting.

## TROUBLESHOOTING

This section of the operator's manual describes how to look for and repair malfunctions, which may occur. Accurate troubleshooting is based on a thorough and complete understanding of the **ENGINE**, **VACCUM**, **SAFETY** and **WIRING** systems featured in this unit.

If there are malfunctions occurring on this unit which you do not understand, refer back to the **OPERATION** section of this manual and review **SYSTEM**.

**ENGINE TROUBLESHOOTING****ENGINE WILL NOT START (STARTER DOES NOT TURN OVER)**

<b>PROBABLE CAUSE</b>	<b>SOLUTION</b>
Main circuit breaker on the control panel has been tripped.	After inspecting the unit to determine the cause of the tripped breaker, press the reset button.
Loose or corroded battery connections.	Clean, tighten or replace the battery terminals.
Dead battery.	Recharge or replace battery
Defective starter motor.	Test the starter motor. Replace if necessary.
Vacuum pump seized.	Refer to the vacuum pump manufacturer service and repair manual.

**STARTER TURNS OVER BUT ENGINE WILL NOT START**

<b>PROBABLE CAUSE</b>	<b>SOLUTION</b>
Recovery tank is full.	Empty the recovery tank.
Defective fuel pump.	Replace the fuel pump.
Loose or broken wires leading to the recovery tank float switch.	Repair or replace any broken electrical connections.
Defective float switch in the recovery tank.	Check switch for proper operation. Replace if necessary.
Oil pressure switch (located on engine), fuel shut-off solenoid (located on engine).	Test these components. If any are defective, replace. Consult the Hyundai Engine Operation and Maintenance Manual.

**ENGINE STOPS RUNNING DURING NORMAL OPERATION**

<b>PROBABLE CAUSE</b>	<b>SOLUTION</b>
Engine is out of gasoline.	Check the fuel tank.
Recovery tank is full.	Empty recovery tank.
Main circuit breaker on the control panel has been tripped.	After inspecting the unit to determine the cause of the tripped breaker, press the reset button.
Defective fuel pump.	Replace fuel pump.
Defective float switch inside recovery tank.	Check switch for proper operation. Replace if necessary.
Oil pressure switch on engine has shut down due to insufficient oil pressure.	Refer to the Hyundai Engine Operation and Maintenance Manual. <b>DO NOT</b> restart the engine until the cause is determined and corrected.
No ignition in the engine or the engine is malfunctioning.	Refer to the Hyundai Engine Operation and Maintenance Manual.

**SEE BACK OF MANUAL FOR ENGINE DIAGNOSTIC CODES**

**VACUUM PUMP TROUBLESHOOTING****LOSS OF VACUUM** (while cleaning, engine RPM is normal but vacuum is lower than expected)

<b>PROBABLE CAUSE</b>	<b>SOLUTION</b>
Vacuum gauge is giving an improper reading.	Examine the tubing between the vacuum relief valve and the vacuum gauge and remove any blockage.
Vacuum hose(s) is damaged, causing a suction leak.	Inspect hose(s), repair or replace.
Recovery tank gaskets not sealing properly, not positioned properly.	Inspect the gasket. Repair seal or replace Re-position lid(s).
Plugged vacuum hose or vacuum plumbing between vacuum inlet and strainer basket.	Unplug vacuum hose or inlet plumbing.
Recovery tank filter or strainer basket is plugged.	Clean or replace filter. Clean strainer basket.
Loose vacuum pump drive belts.	Tighten the drive belts.
Recovery tank drain valve is damaged or left open, causing a vacuum leak.	Drain the recovery tank. Close drain valve, if open. Replace valve if defective.
Vacuum relief valve requires adjustment or has a vacuum leak due to damaged diaphragm.	Re-adjust the vacuum relief valve. If the vacuum does not increase, remove and inspect the relief valve diaphragm. If damaged, replace.
Vacuum pump is worn out.	Replace the vacuum pump.

**EXCESSIVE VACUUM** (while cleaning, engine RPM is normal but vacuum is higher than expected)

<b>PROBABLE CAUSE</b>	<b>SOLUTION</b>
Vacuum relief valve requires adjustment.	Readjust vacuum relief valve to 13" Hg.

**HEAT EXCHANGER/TEMPERATURE RELATED TROUBLESHOOTING****EXCESSIVE HEATING**

<b>PROBABLE CAUSE</b>	<b>SOLUTION</b>
Flow restriction caused by hard water scaling.	Descale unit, repair or replace damaged plumbing components as necessary. Install a water softener.
Not enough water flowing during normal operation.	Check jet size of tool.

**LOSS OF TEMPERATURE**

<b>PROBABLE CAUSE</b>	<b>SOLUTION</b>
No vacuum hose is connected.	Connect vacuum hose to vacuum inlet port.
Temperature relief valve on water box is stuck open.	Clean temperature relief valve and test. Replace if necessary.
Engine RPM is low.	Reset engine RPM
Defective temperature gauge.	Test gauge and sensor. Replace failed component.
Temperature balance orifice missing.	Replace orifice.

**HEAT EXCHANGER LEAKING**

<b>PROBABLE CAUSE</b>	<b>SOLUTION</b>
Water is dripping from the exhaust port due to condensation build-up.	NOTE: The heat exchanger will produce water condensation discharge at times during normal operation. Do not confuse this with a leak.
Heat exchanger is damaged from frozen water.	Inspect heat exchanger for leaks. Visually inspect for damage. Pressure check after removing the unit (maximum test pressure – 1500 PSI).

**PRESSURE PUMP TROUBLESHOOTING****LOSS OF SOLUTION PRESSURE (CLEANING TOOL OPEN, SOLUTION GAUGE READS LOW)**

<b>PROBABLE CAUSE</b>	<b>SOLUTION</b>
Water supply is turned off or the float valve is stuck.	Turn the water supply on or up. Check for kinks in the water supply hose. Examine the float or replace.
Solution pump inlet supply line is plugged or drawing air.	Examine the water inlet filter inside the water box. Remove accumulated debris and replace if required. Check for suction leaks and loose clamps or fittings. Tighten any loose fittings or clamps. Replace any ruptured hose(s).
Pressure regulator o-rings are dry. See instructions on regulator.	Lubricate o-rings, using o-ring lubricant.
Pressure regulator has worn o-rings. See instructions on regulator.	Check o-rings. If necessary, replace.
Pressure regulator is dirty, stuck open, or improperly adjusted. See instructions on regulator.	Clean or repair regulator. Adjust to working pressure. Lubricate o-rings, using o-ring lubricant.
Low pump volume. (Measure the amount of water being returned to the water box from the pressure regulator. It should fill a gallon container about every 17.6 seconds).	Examine the check valves, plunger cups, and cylinder head on the water pump. Repair, whenever required (refer to the water pump service manual).
Defective water pressure gauge.	Replace gauge.
Orifice (spray nozzle) in the cleaning tool is worn, defective or wrong size.	Replace Nozzle or change nozzle size.
Debris clogging water lines or water inlet disconnect.	Clean or replace as needed.
Belts loose or broken.	Re-tension or replace as needed.
Loss of pump prime.	Manually prime water pump.
Temperature Balance Orifice missing.	Replace Orifice.

**LOSS OF SOLUTION VOLUME AT TOOL (PRESSURE GAUGE READS NORMAL)**

<b>PROBABLE CAUSE</b>	<b>SOLUTION</b>
Plugged orifice and/or screen in the cleaning tool.	Unplug or replace orifice and/or screen.
Internal block between the pressure regulator manifold and the outlet manifold, or the solution screen is clogged.	Inspect all lines, remove accumulated debris which is blocking flow. Replace any defective hoses. Remove, inspect, and clean the solution screen. De-scale unit and install a water softener, if necessary.
Outlet check valve is plugged.	Examine the check valve, remove any debris.
Defective quick-connect on one or more of the high pressure hoses.	Replace defective quick-connect(s) on high pressure hoses(s).
Cleaning tool valve is malfunctioning.	Repair or replace valve.
Hose inner lining is constricted.	Remove restriction or replace hose.
Air leak in chemical supply line, priming valve or metering valve.	Check for air leaks. Replace faulty parts.

**CHEMICAL SYSTEM TROUBLESHOOTING****CHEMICAL FLOW METER INDICATES FLOW WITH TOOL VALVE CLOSED**

<b>PROBABLE CAUSE</b>	<b>SOLUTION</b>
External leak in chemical piping.	Tighten or replace fittings. Re-apply thread sealant where required.
Outlet check valve is full of debris or damaged, not allowing it to close properly.	Close the chemical valve on the instrument panel. If the flow meter does not indicate flow, remove debris or replace check valve, if necessary.
Chemical pump diaphragm is ruptured.	Close the chemical valve on the instrument panel. If the flow meter still indicates flow, replace the chemical pump diaphragm.
Internal leak in chemical valve causing continual flow through prime tube returning to container.	Tighten valve packing nut (see "General Service Adjustments"). Replace valve, if necessary.

**SOLUTION PUMP DOES NOT ENGAGE**

<b>PROBABLE CAUSE</b>	<b>SOLUTION</b>
Solution pump circuit breaker has been tripped.	Check the solution pump circuit breaker on the control panel. Press the circuit breaker reset button.
Defective electrical connection in the console wiring or defective switch.	Examine switch, electrical connections, and wiring. Repair any defective connections. If there is power going to the switch but not going out, replace the defective switch.
Solution pump has not been activated.	Turn solution pump switch to on.
Defective solution pump clutch. NOTE: The clutch may be manually engaged by inserting two ¼-20 x ½ bolts. Line up the holes on the clutch and insert the bolts. To disengage the pump, remove the bolts.	If there is power in the switch, but not power at the clutch, replace the defective wire. If there is power at the clutch, replace the defective switch.
Loose or broken solution pump belts.	Tighten or replace belts.



**LOSS OF CHEMICAL (CLEANING TOOL OPEN, NO CHEMICAL)**

<b>PROBABLE CAUSE</b>	<b>SOLUTION</b>
Chemical pump is improperly primed.	Refer to chemical pump priming instructions.
The strainer at the inlet end of the chemical inlet line is clogged.	Unclog the strainer. If damaged, replace.
Suction leak in the inlet line leading into the chemical pump.	Inspect inlet lines and flow meter for air leaks or damage.
Chemical pump check valve(s) is clogged.	Remove any debris from the chemical check valve(s). Replace chemical check valve(s) or seals, if necessary.
Chemical prime/on-off valve or chemical metering valve is defective.	Replace valve(s).
Chemical pump diaphragm is ruptured.	Disassemble the chemical pump and replace the damaged diaphragm.
Defective cylinder in the water pump.	Measure the pump volume. If the pump volume is less than normal, refer to “Loss of Solution Volume” in this section.

**WASTE PUMP (IF INSTALLED) TROUBLESHOOTING****WASTE PUMP NOT OPERATING NORMALLY**

<b>PROBABLE CAUSE</b>	<b>SOLUTION</b>
Defective waste pump float switch.	Replace float switch.
Broken diaphragm(s).	Replace diaphragm(s).
Weak battery.	Charge or replace battery if needed. Check charging station.
Pump-out circuit breaker on control panel has been tripped.	After inspecting waste pump to determine the cause of the tripped circuit breaker, press the reset button.
Inspect check valve for debris or damage.	Clean or replace if necessary.

## SECTION FIVE: PARTS AND ACCESSORIES

### ILLUSTRATED PARTS LISTING

CONSOLE ASSEMBLY .....	63
FRAME AND ENCLOSURES .....	64
INSTRUMENT PANEL .....	68
TERMINAL BLOCK .....	70
TEMPERATURE CONTROL MODULE .....	71
PRESSURE REGULATOR LATCH .....	72
ENGINE .....	73
INLINE THERMOSTAT .....	75
HYUNDAI HOSES AND CONNECTOR TUBES .....	76
RADIATOR .....	77
VACUUM PUMP .....	79
VACUUM RELIEF VALVE .....	81
PRESSURE PUMP .....	82
THERMAL WELL .....	84
COOLANT HEAT EXCHANGER .....	86
EXHAUST, CATALYST AND SILENCER .....	87
BYPASS COOLER .....	88
CRANK VENT ADAPTER .....	89
SOLUTION MANIFOLD .....	90
QD BRACKET .....	92
PRESSURE REGULATOR .....	93
OIL CUP AND BYPASS .....	94
RECOVERY TANK .....	95
DECALS .....	96

**70-870H, CONSOLE, 870H (FIG. 1 OF 2)**

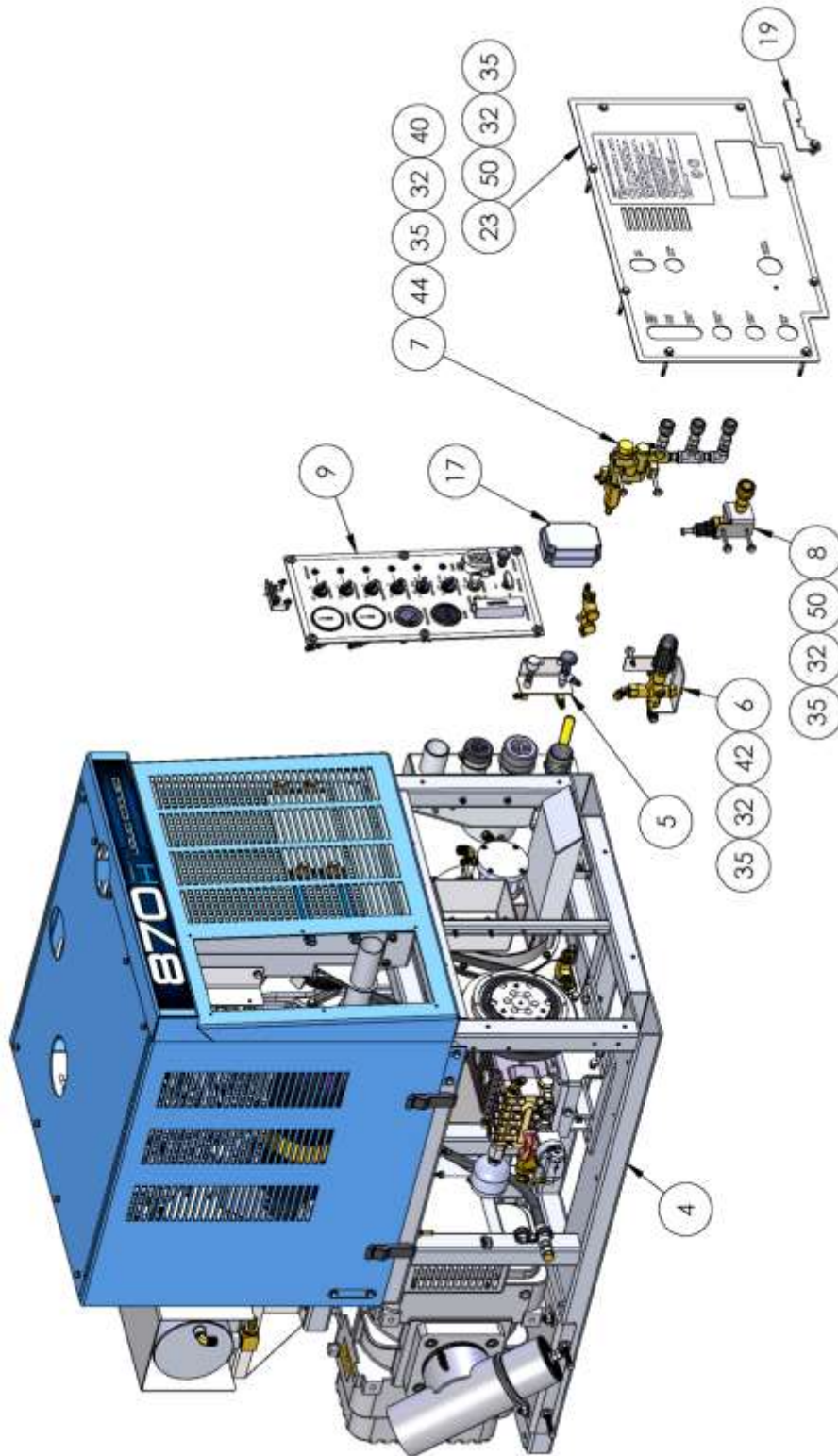

**70-870H, CONSOLE, 870H (FIG. 2 OF 2)**

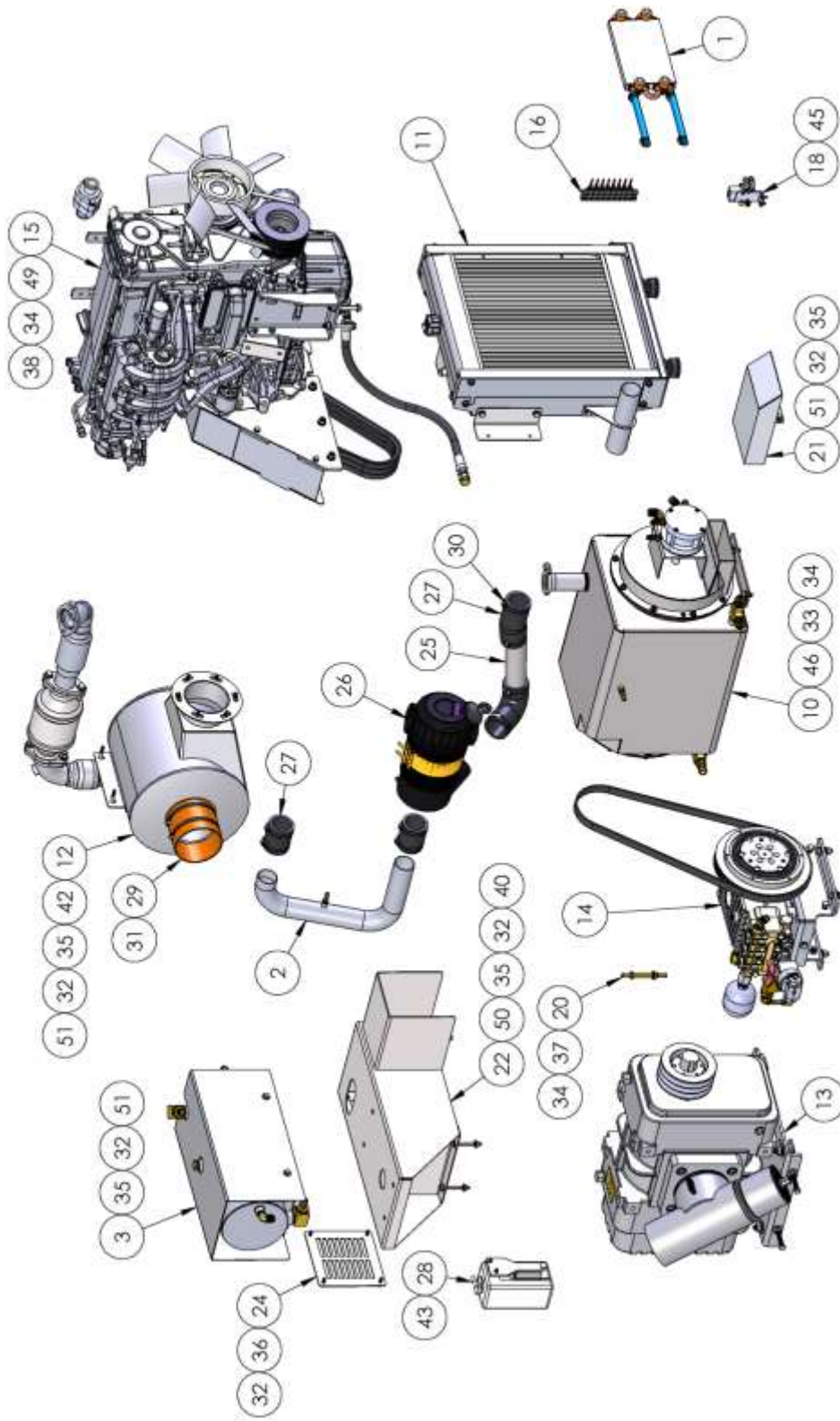

**70-870H, CONSOLE, 870H – BOM TABLE**

2	52	10-003	BOLT, 1/4-20 X 3 1/2 HH ZP
17	51	10-025	SCREW, MACH 1/4-20 X 3/4 HXHD GRD5
12	50	10-028	SCREW, MACH 1/4-20 X 2-3/4 HXHD
4	49	10-030	SCREW, MACH 3/8-16 X 3 HXHD
5	48	10-036	SCREW, MACH 5/16-18 X 1-1/4 HXHD
4	47	10-042	SCREW, MACH, .25-20 X 1.25 HXHD ZINC
4	46	10-070	BOLT - .375-16 X .75 HH ZP
2	45	10-150	SCREW - 10-32 X .500 PHP ZP
2	44	10-160	BOLT, 1/4-20 X 4 1/2 HH ZP
2	43	10-165	SCREW, MACH 1/4-20 X .50 FHSCS SS
4	42	10-170	SCREW, MACH, 3/8-16 X 2-3/4 HH G5
2	41	10-392	SCREW, M12-1.75 x 30MM FHCS G10.9 ZP
7	40	11-004	NUT, 1/4-20 ZINC
5	39	11-006	NUT, 3/8-16 ZINC
4	38	11-019	NUT,3/8-16 NYLOK
1	37	11-088	NUT, 7/16-20 THIN NYLOK ZPS
7	36	12-011	WASHER, FLAT #12 SAE
35	35	12-012	WASHER, FLAT 1/4 USS
23	34	12-013	WASHER, FLAT 3/8 SAE
9	33	12-014	LKWSR, 3/8 ZINC
42	32	12-015	LKWSR, 1/4 ZINC
2	31	14-008	CLAMP, HOSE #72
8	30	14-010	CLAMP, HOSE #32
1	29	16-110	HOSE, 4.5 ID X 3 FT SILICONE 550F
1	28	36-040	BOTTLE, O/F KUBOTA#1906972090
3	27	36-401	HOSE, RADIATOR 1.00 ID NAPA 8205
1	26	36-423	ASSY, AIR CLEANER
8 IN	25	55-041	TBG, 2.00 OD X .049 WALL 304 SS
1	24	58-892	PLATE, HEAT EXCH MOUNT COVER
1	23	58-894	PANEL, LOWER FRONT
1	22	61-1373	WELDMENT, HEAT EXCH MOUNT
1	21	61-137B	WELDMENT, EXHAUST EXTENSION
1	20	66-360	FITTING, 5/16 FUEL LINE MANIFOLD
1	19	69-324	ASSY, PRESSURE REGULATOR LATCH
1	18	69-508	ASSY, DIVERTER LOCKOUT 870
1	17	69-634	ASSY, TEMP CONTROL MODULE
1	16	69-649	ASSY, TERMINAL BLOCK 8 CIRCUIT
1	15	69-753	ASSY, ENGINE
1	14	69-762	ASSY, PRESSURE PUMP
1	13	69-764	ASSY, ZG100 EURUS BLOWER 870H
1	12	69-766	ASSY, EXHAUST, CAT AND SILENCER
1	11	69-767	ASSY, RADIATOR
1	10	69-772	ASSY, HEAT EXCHANGER
1	9	69-774	ASSY, INSTRUMENT PANEL
1	8	69-775	ASSY,QD BRACKET
1	7	69-789	ASSY, MANIFOLD BLOCK & BYPASS
1	6	69-790	ASSY, PRESSURE REGULATOR
1	5	69-792	ASSY, OIL CUP AND BYPASS VALVE
1	4	69-800	ASSY, FRAME AND ENCLOSURES
1	3	69-815	ASSY, COOLANT HEAT EXCHANGER
1	2	69-818	ASSY, CRANK VENT ADAPTER
1	1	69-822	ASSY, BYPASS COOLER
QTY	ITEM	PART NO.	DESCRIPTION

**69-800, ASSEMBLY, FRAME AND ENCLOSURES**

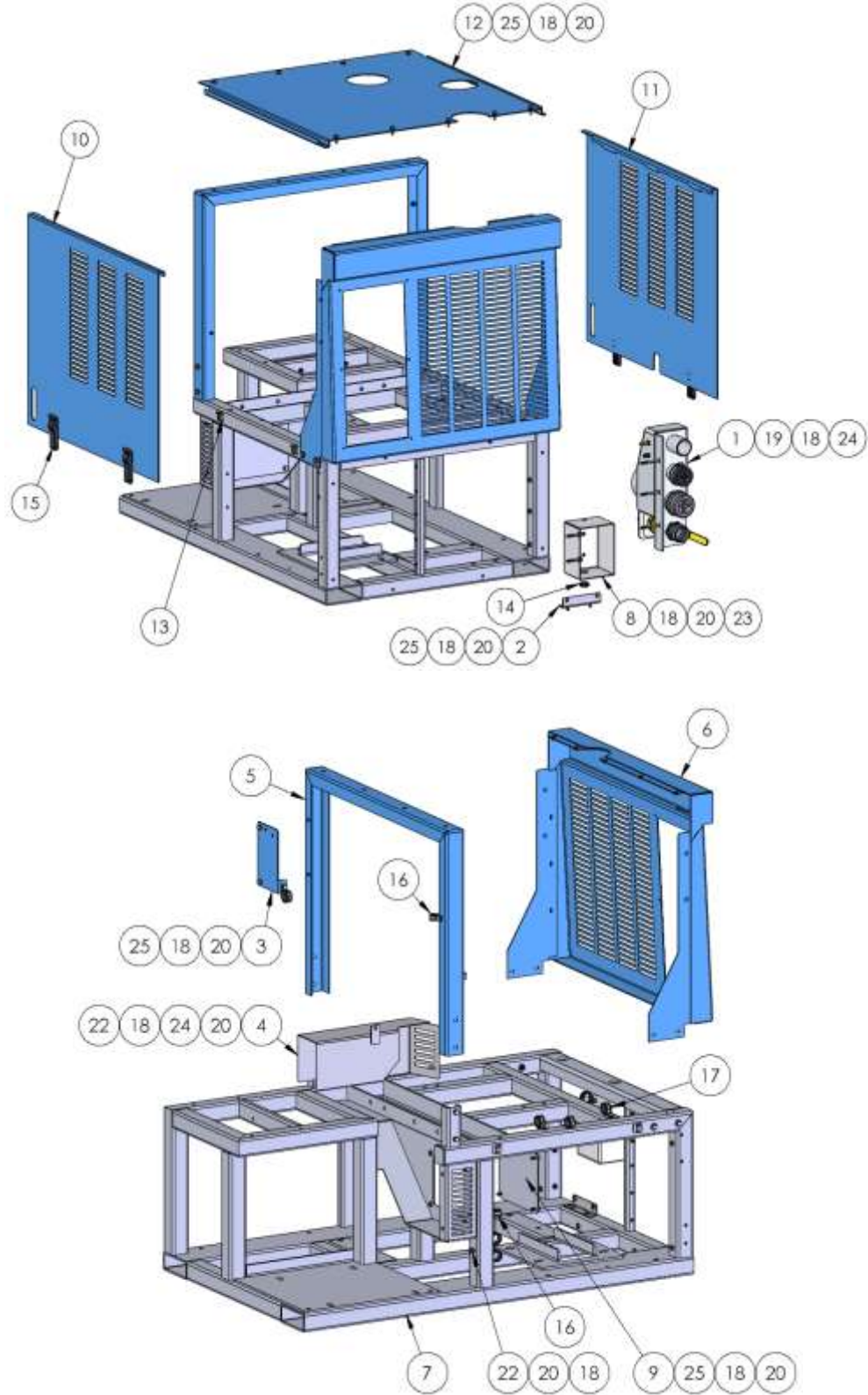

**69-800, ASSEMBLY, FRAME AND ENCLOSURES – BOM TABLE**

26	25	10-025	SCREW, MACH 1/4-20 X 3/4 HXHD GRD5
12	24	10-028	SCREW, MACH 1/4-20 X 2-3/4 HXHD
2	23	10-170	SCREW, MACH, 3/8-16 X 2-3/4 HH G5
5	22	11-004	NUT, 1/4-20 ZINC
2	21	11-000	NUT, INSERT 1/4-20 PRESS CADMIUM
37	20	12-011	WASHER, FLAT #12 SAE
8	19	12-012	WASHER, FLAT 1/4 USS
40	18	12-015	LKWSR, 1/4 ZINC
9	17	14-003	CLAMP,WIRE CUSHION 1.00 ID X 1/4 BOLT
2	16	14-005	CLAMP,WIRE CUSHION 5/8 ID X 1/4 BOLT
4	15	40-034	LATCH, DRAW SS CONCEALED MOUNT
1	14	41-096	GROMMET, 1-1/8 OD X 5/8 ID X 1/8 PANEL
4	13	58-699	PLATE, LATCH SPACER
1	12	58-868	PANEL, TOP
1	11	58-869	PANEL, RIGHT SIDE
1	10	58-870	PANEL, LEFT SIDE
1	9	58-871	COVER, PULLEY ACCESS
1	8	61-1129	WELDMENT, TEMP CONTROL BOX
1	7	61-1282	WELDMENT, FRAME
1	6	61-1293	WELDMENT, BEZEL FRAME
1	5	61-1303	WELDMENT, REAR BRACE
1	4	61-1307	WELDMENT, EXHAUST HEAT SHIELD
1	3	61-1376	WELDMENT, OVERFLOW MOUNTING
1	2	61-1379	WELDMENT, EXHAUST EXT MOUNT
1	1	69-323	ASSY, VACUUM BRACKET
QTY	ITEM	PART NO.	DESCRIPTION

**69-774, ASSEMBLY, INSTRUMENT PANEL**

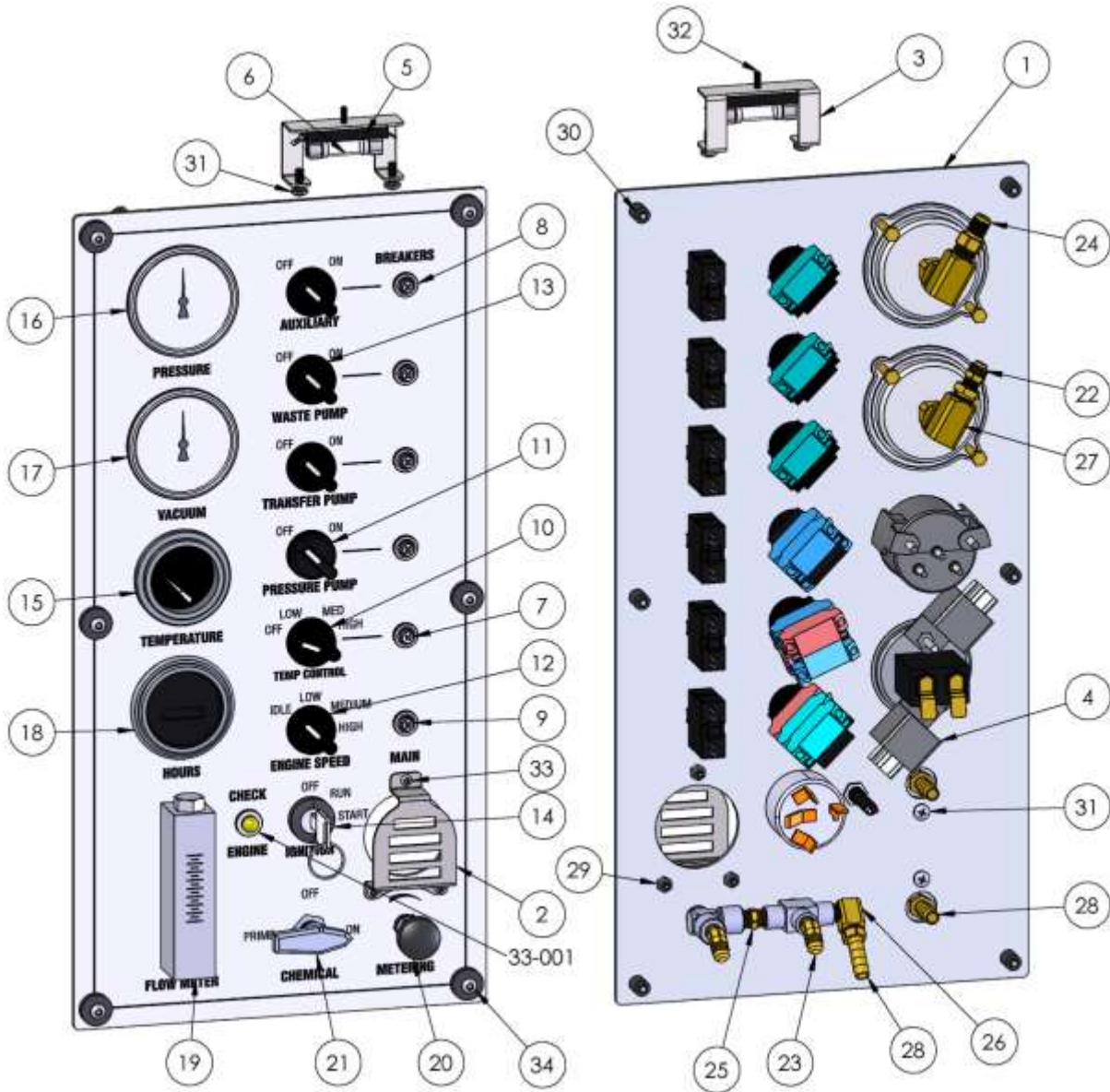



**69-774, ASSEMBLY, INSTRUMENT PANEL – BOM TABLE**

6	34	10-016	SCREW, MACHINE 10-32 X 1 SOCHD SS
3	33	10-113	SCREW, MACH 6-32 X 1/2 BHSCS SS
1	32	10-149	SCREW, 6-32 X 1-2 PHP ZP
4	31	10-150	SCREW - 10-32 X .500 PHP ZP
6	30	11-002	NUT, WELL G 10-32
3	29	11-021	NUT, 6-32 NYLOK
3	28	21-007	FTTG, BRB 1/8 P X 5/16 H BR
2	27	21-037	ELL, 1/4 IN. BRASS
1	26	21-038	ELL, STREET 1/8 IN BRASS
1	25	21-045	NIP, 1/8 IN HEX BRASS
1	24	21-050	CONN, 1/4 NPT X 1/4 JIC BRASS
2	23	21-055	ELL, 1-8 P X 1/4 T 45 DEG BRASS
1	22	21-433	CONN, 1/4 P X 1/4 POLY
1	21	23-027	VALVE, 3-WAY BALL 1/8 FP SS
1	20	23-028	VLV, MET 1/8 FP (CHEM) RT ANG SS
1	19	26-003	FLOWMETER, 1/8 FP
1	18	26-033	HOURMETER, HOBBS CHROME BEZEL
1	17	26-044	GAUGE, VACUUM 2.5 IN 0-30 IN/HG
1	16	26-046	GAUGE, PRESSURE 2.5 IN 0-5000 PSI
1	15	26-049	GAUGE, WTR TEMP CHROME 280 DEG.
1	14	29-007	SWITCH, STARTER & KEY 3 POSITION
3	13	29-016	SWITCH, ROTARY NON-ILLUMINATED
1	12	29-058	SWITCH, 870 THROTTLE CONTROL
1	11	29-063	SWITCH, ROTARY, 3 NO
1	10	29-072	SWITCH, ROTARY, 4POS 2NO 2NC
1	9	30-007	BREAKER, 30 AMP
4	8	30-008	BREAKER, 20 AMP
1	7	30-134	BREAKER, 10 AMP
1	6	33-002	LIGHT, FESTOON LED 12V
1	5	33-003	HOLDER, FESTOON LIGHT
2	4	34-010	RELAY, ENG.SHTDWN12V20/30AMP
1	3	58-502	FORMING, BEZEL LIGHT BRACKET
1	2	58-898	PANEL, AIR INLET GUARD
1	1	66-540	PANEL, INSTRUMENT 870H SCREENED
QTY	ITEM	PART NO.	DESCRIPTION

**69-649, ASSEMBLY, TERMINAL BLOCK**

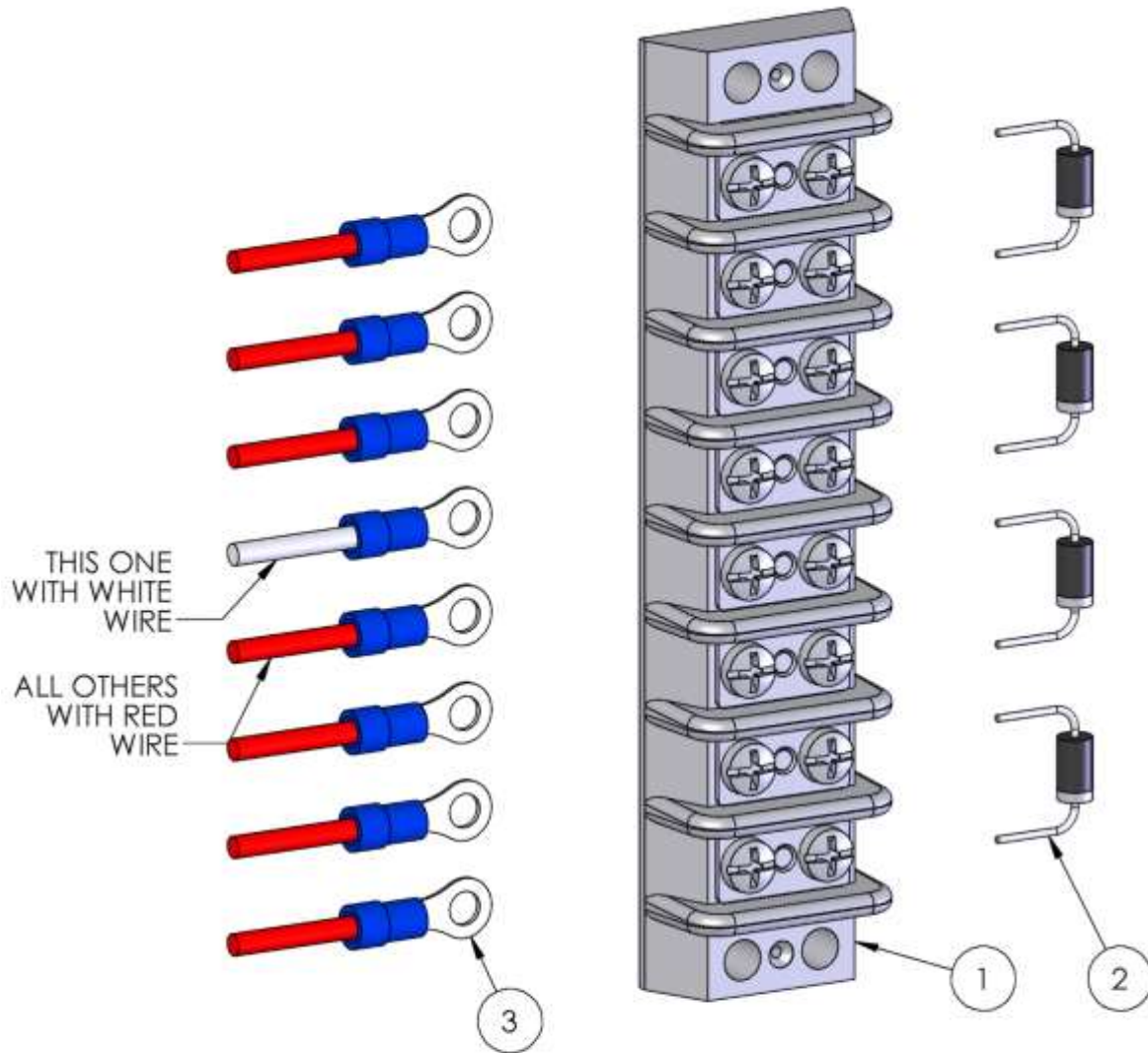

QTY	ITEM	PART NO.	DESCRIPTION
8	3	31-030	TERM, RING 14-16 GA. #10 BLUE
4	2	30-107	DIODE, TVS18.8VWM 30.6 VC AXIAL
1	1	30-019	BLOCK, TERMINAL 8 POSITION

**69-634, TEMPERATURE CONTROL MODULE**

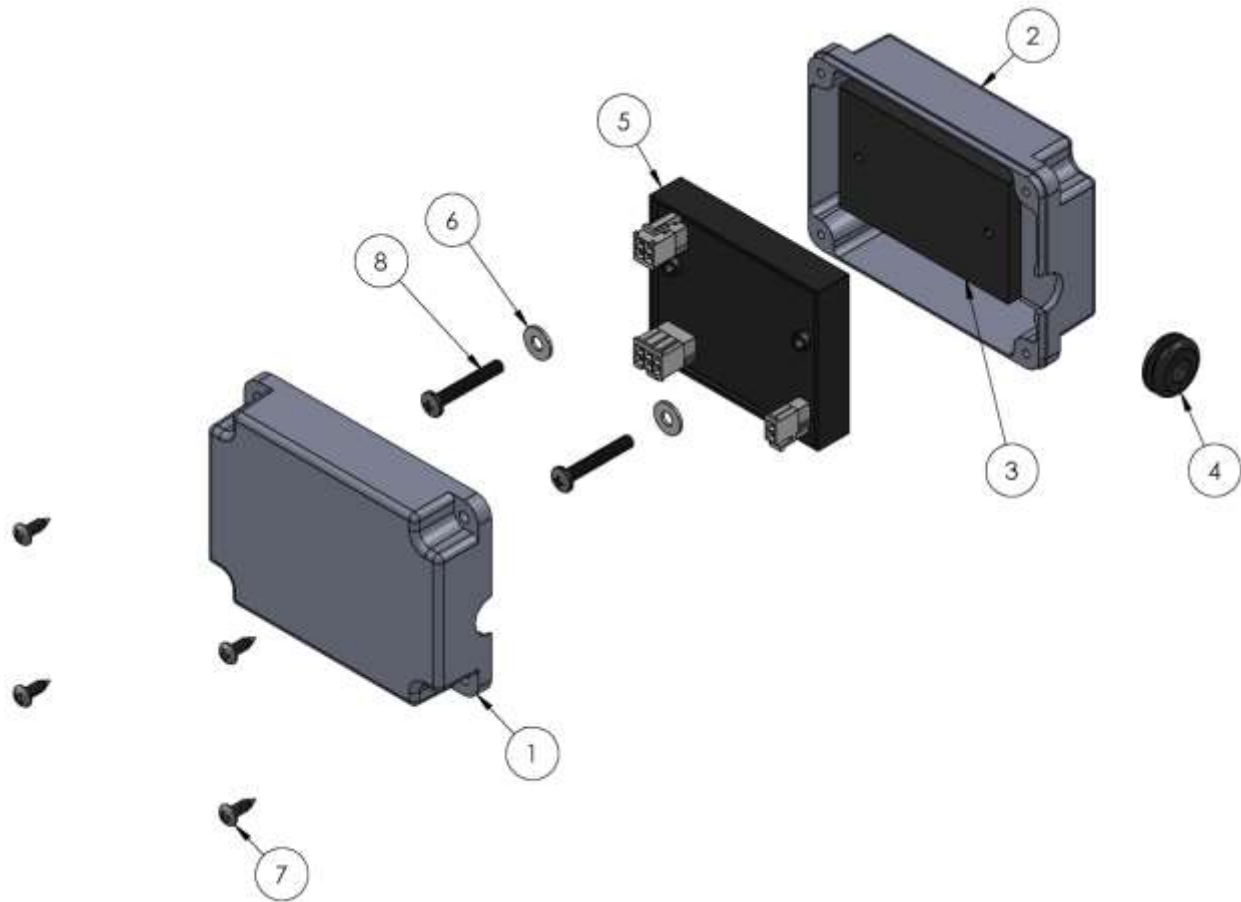

2	8	10-252	SCREW, MACH 10-32 X 1-1/4 PPH ZP
4	7	10-310	SCREW, SHEET METAL #8-15 X 1/2 PPH ZP
2	6	12-091	WASHER, FLAT #10 SAE ZP
1	5	34-045	MODULE, TEMP CONTROL
1	4	41-070	GROMMET, 7/8" OD X 3/8" ID X 1/8" PANEL
1	3	41-164	PAD, THERMAL MODULE ISOLATION
1	2	51-086	MOLDING, TEMP CNTL BOX BOTTOM
1	1	51-087	MOLDING, TEMP CNTL BOX LID
QTY	ITEM	PART NO.	DESCRIPTION

**69-324, ASSEMBLY, PRESSURE REGULATOR LATCH**

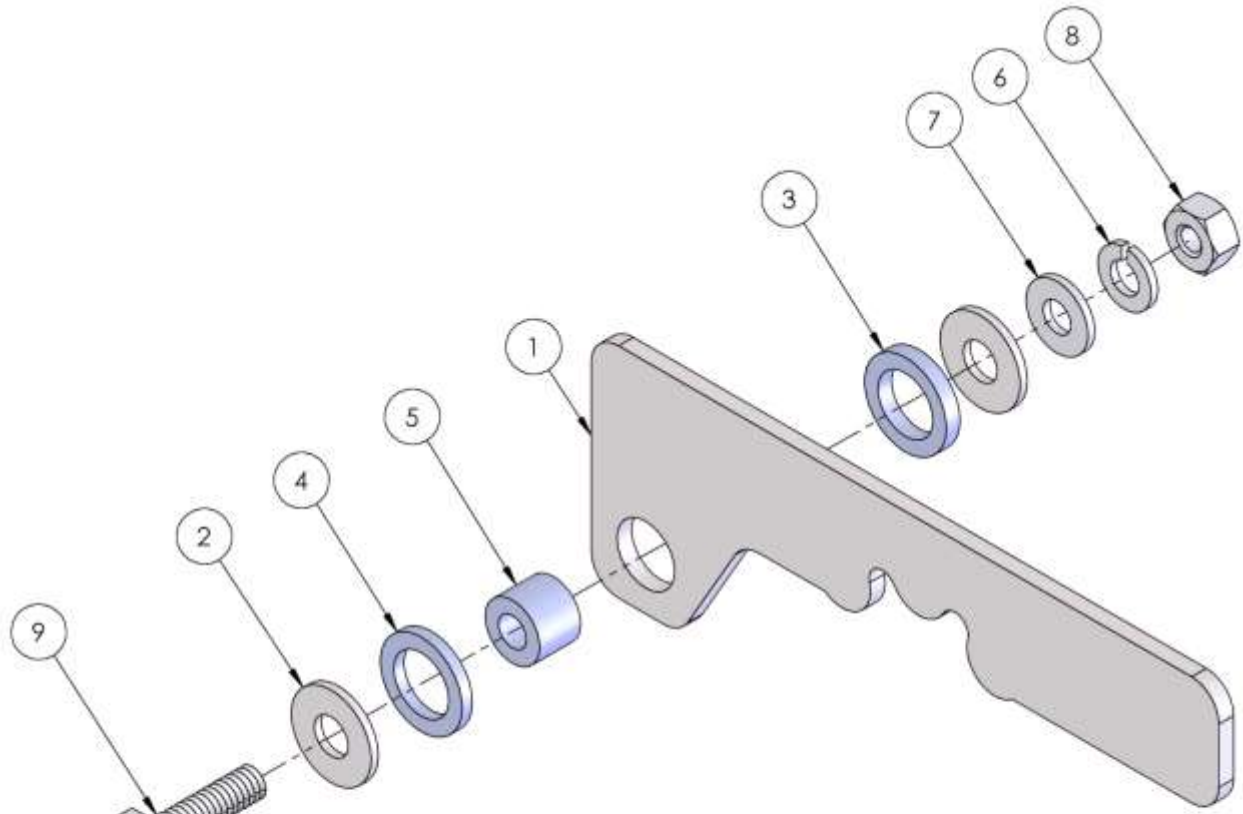

1	9	10-026	SCREW, MACH 1/4-20 X 1 HXHD
1	8	11-004	NUT, 1/4-20 ZINC
1	7	12-011	WASHER, FLAT #12 SAE
1	6	12-015	WKWSR, 1/4 ZINC
1	5	12-051	SPACER, 1/2 OD X 3/8 L X #14 HOLE NYLON
1	4	12-052	WASHER, FLT .505 ID X .75 OD X .093 THK NYLON
1	3	12-053	WASHER, FLT .505 ID X .75 OD X .125 THK NYLON
2	2	12-054	WASHER, FLT 1/4 X .734 OD ZINC
1	1	58-710	LEVER, REGULATOR STOP
QTY	ITEM	PART NO.	DESCRIPTION

**69-753, ASSEMBLY, ENGINE**

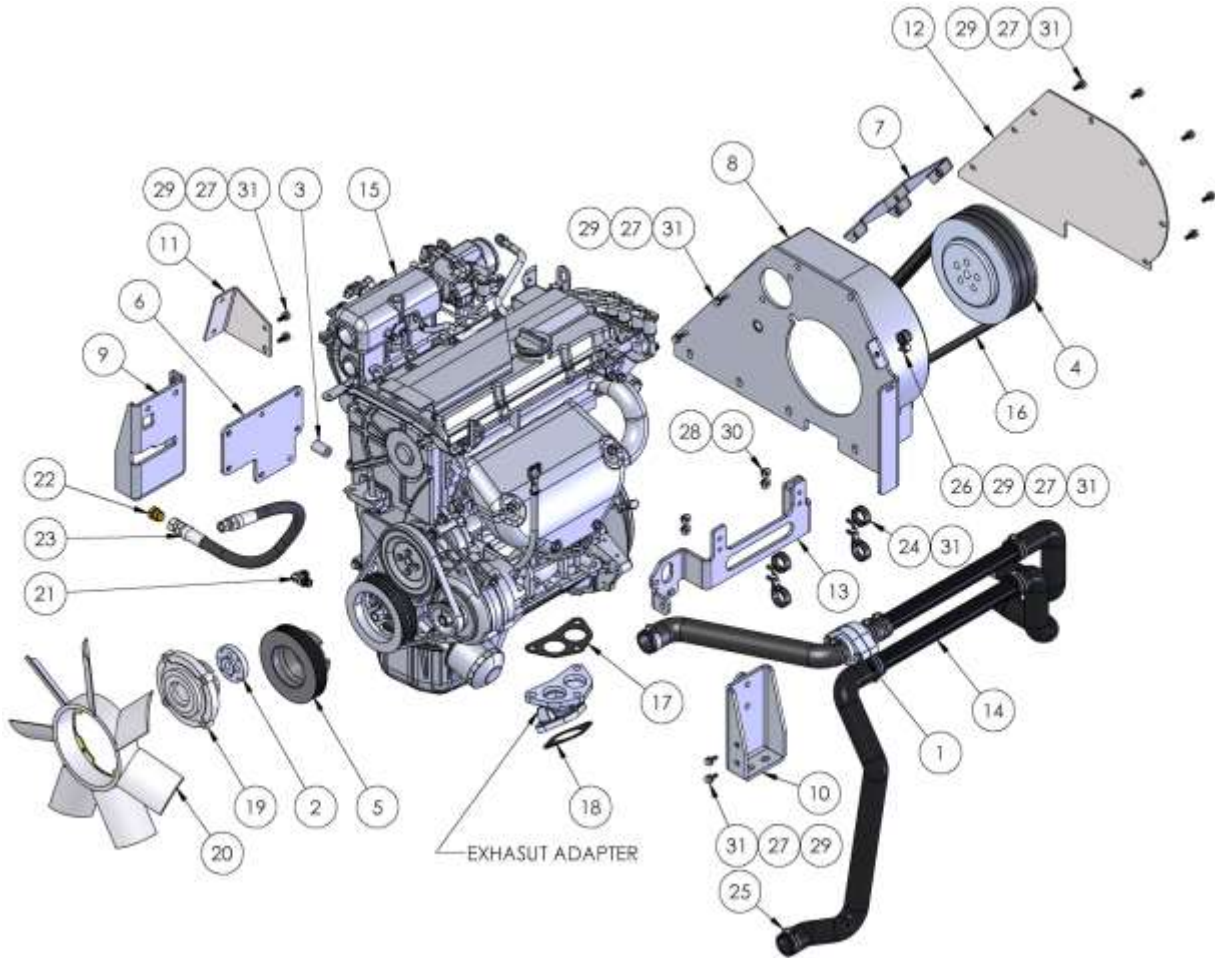

**69-753, ASSEMBLY, ENGINE – BOM TABLE**

18	31	10-032	SCREW, MACH 1/4-20 X 3/4 HXHD
4	30	11-013	NUT, 1/4-20 NYLOK SS
14	29	12-011	WASHER, FLAT #12 SAE
4	28	12-012	WASHER, FLAT 1/4 USS
14	27	12-015	LKWSR, 1/4 ZINC
1	26	14-005	CLAMP,WIRE CUSHION 5/8 ID X 1/4 BOLT
10	25	14-006	CLAMP, HOSE #20 SS
4	24	14-022	CLAMP, 1-1/4 ID VINYL COVERED
1	23	18-344	HOSE ASSY, .50 ID X 06 FJX X 08 FJX X 26L
1	22	21-027	PLUG, 1/2 T BR
1	21	21-575	ADAPTER, 06 MJIC X 14MM ORB 90 DEG
1	20	35-046	FAN, 15 IN 7 BLADE NISSAN
1	19	35-047	CLUTCH, FAN NAPA 274310
1	18	36-520	GASKET, EXHAUST 1.6L HYUNDAI
1	17	36-532	GASKET, EXHAUST 1.6L 3 BOLT
3	16	37-107	BELT, 5VX510 GATES EPDM
1	15	45-058	ENGINE, HYUNDAI 1.6L
1	14	48-109	KIT, HYUNDAI 1.6 HOSE AND TUBE
1	13	58-862	BRACKET, RAD SUPP ENG
1	12	58-873	PLATE, BELT GUARD COVER
1	11	58-875	PANEL, AIR CLEANER MOUNT
1	10	61-1279	WELDMENT, MOTOR MOUNT RS
1	9	61-1280	WELDMENT, ENGINE MOUNT LS
1	8	61-1281	WELDMENT, ENGINE MOUNT REAR
1	7	61-1312	WELDMENT, INSPECTION COVER
1	6	61-1317	WELDMENT, ECU MOUNT
1	5	66-531	PULLEY, ENGINE FRONT
1	4	66-532	PULLEY, ENGINE REAR 3G 5V
1	3	66-537	SPACER, ECU MOUNT
1	2	66-561	ADAPTER, VISCOUS FAN
1	1	69-819	ASSY, INLINE THERMOSTAT
QTY	ITEM	PART NO.	DESCRIPTION

**69-819, ASSEMBLY, INLINE THERMOSTAT**

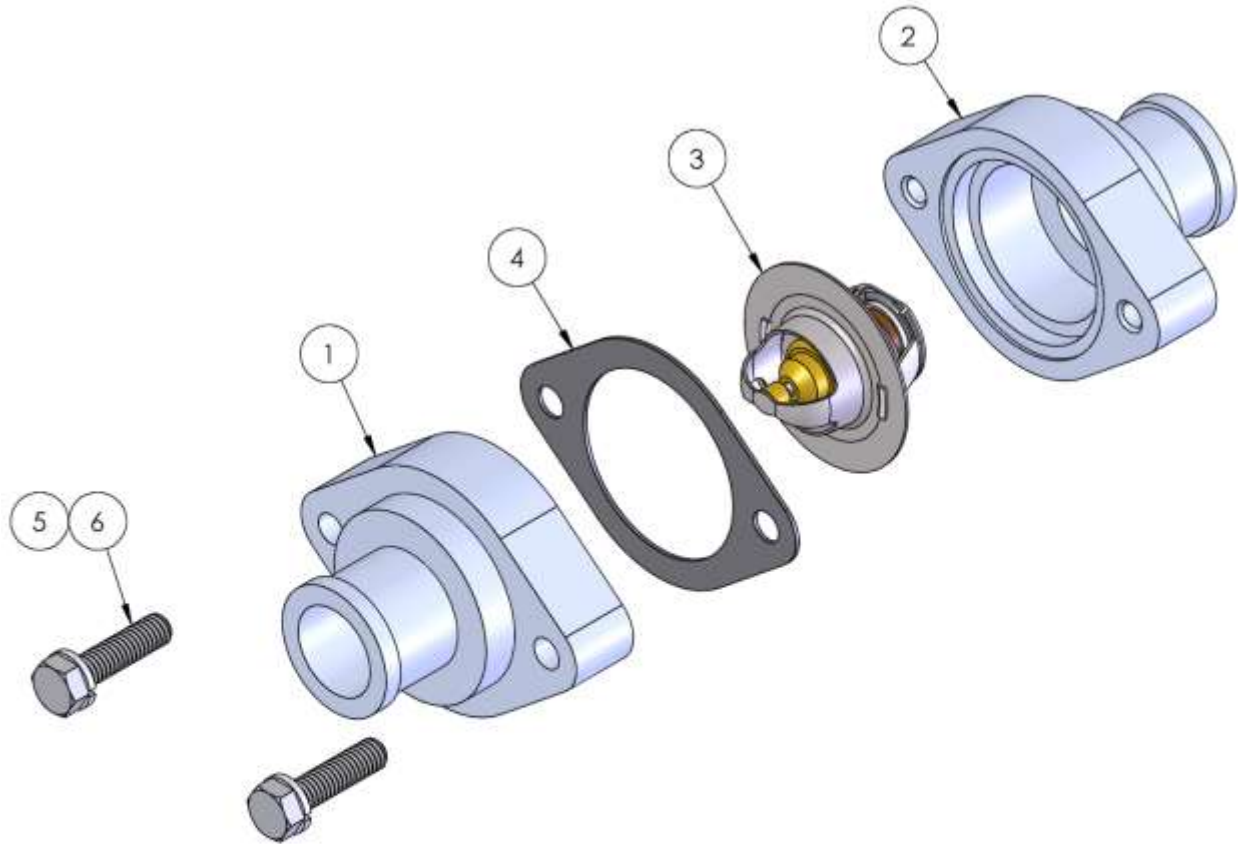

2	6	10-023	SCREW, MACH 5/16-18 X 1-1/4 HXHD SS
2	5	12-016	LKWSR, 5/16 ZINC
1	4	36-109	GASKET, THERMOSTAT NISSAN
1	3	36-127	THERMOSTAT, NISSAN 195 DEG
1	2	66-559	THERMOSTAT HSG, BOT HALF
1	1	66-560	THERMOSTAT HSG, TOP HALF
QTY	ITEM	PART NO.	DESCRIPTION

**48-109, KIT, HYUNDAI HOSES AND CONNECTOR TUBES**



1	5	68900362	HOSE, 20R4, 32 ID HYUNDAI 1.6L FRONT BOTTOM
1	4	68900361	HOSE, 20R4, 32 ID, HYUNDAI 1.6L TOP FRONT
1	3	68900360	HOSE, 20R4, DIA 32, HYUNDAI 1.6 LOWER REAR
1	2	68900359	HOSE, 20R4, DIA 32, HYUNDAI 1.6 TOP REAR
2	1	62410120	CONNECTOR, STRAIGHT 410.0 X 32.00 DIA
QTY	ITEM	PART NO.	DESCRIPTION



**69-767, ASSEMBLY, RADIATOR**

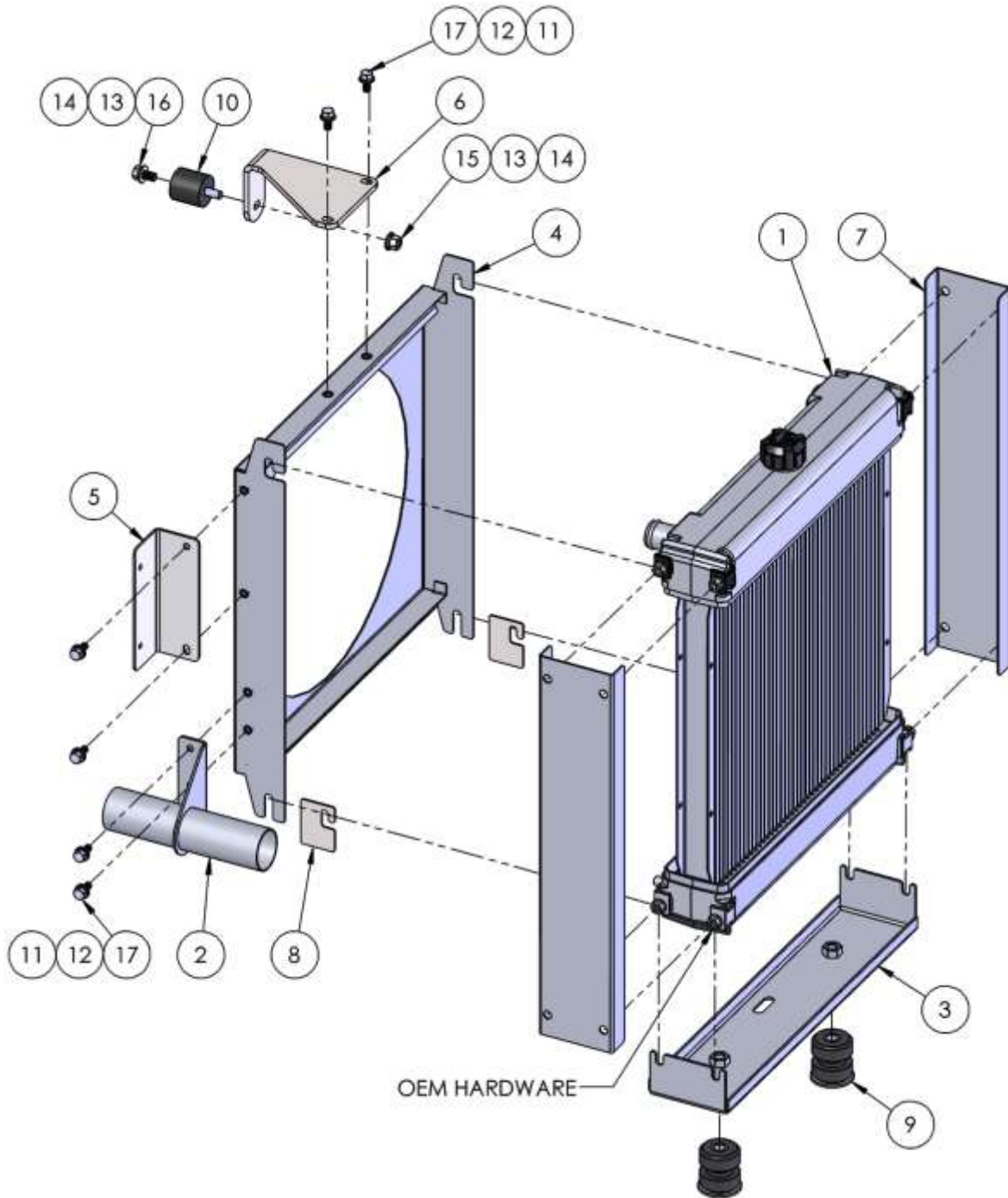

**69-767, ASSEMBLY, RADIATOR - BOM TABLE**

6	17	10-034	BOLT, 5/16-18 X 3/4 HH ZP
1	16	10-070	BOLT - .375-16 X .75 HH ZP
1	15	11-006	NUT, 3/8-16 ZINC
2	14	12-013	WASHER, FLAT 3/8 SAE
2	13	12-014	LKWSR, 3/8 ZINC
6	12	12-016	LKWSR, 5/16 ZINC
6	11	12-017	WASHER, FLAT 5/16 SAE ZINC
1	10	41-110	ISOLATOR, 1.5 OD X 1.5 TALL 50 DURO
2	9	41-195	ISOLATOR, RADIATOR MOUNT
2	8	58-857	PLATE, RADIATOR SHIM
2	7	58-858	PANEL, RADIATOR MOUNT SIDE
1	6	58-861	PANEL, RAD SUPPORT BRACKET
1	5	58-872	BRACKET, FUSE BLOCK
1	4	61-1296	WELDMENT, RAD FAN SHROUD
1	3	61-1300	WELDMENT, RADIATOR MOUNT
1	2	61-1306	WELDMENT, INLET AIR BRACKET
1	1	63-235	RADIATOR, 870H
QTY	ITEM	PART NO.	DESCRIPTION

**69-764, ASSEMBLY, VACUUM PUMP**

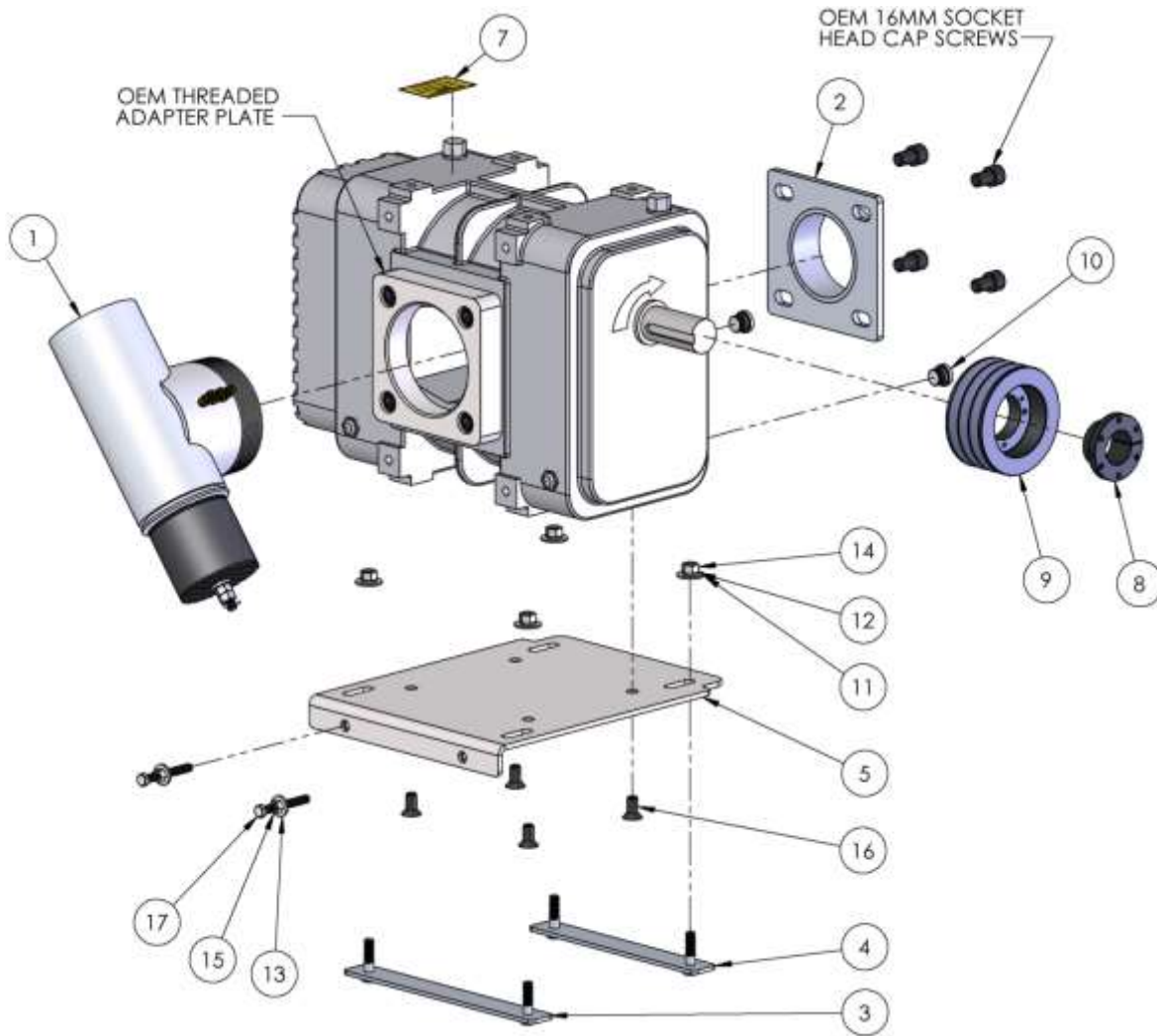

SECTION FIVE – PARTS AND ACCESSORIES

**69-764, ASSEMBLY, VACUUM PUMP – BOM TABLE**

2	17	10-057	BOLT, TAP 3/8-16 X 3 GR 5
4	16	10-262	SCREW, 1/2-13 X 1.00 FHSCS BO
2	15	11-006	NUT, 3/8-16 ZINC
4	14	11-012	NUT, 7/16-14 ZP
2	13	12-013	WASHER, FLAT 3/8 SAE
4	12	12-020	LKWSR, 7/16 ZINC
4	11	12-021	WASHER, FLAT, 7/16 ZINC
2	10	21-520	PLUG, HEX M20-1.5 STEEL
1	9	38-116	PULLEY, 5V5.5 SDS 3G
1	8	38-106	HUB, SDS 42MM
1	7	44-141	PLATE, SERIAL EURUS BLOWER
1	6	46-076	VACUUM PUMP, EURUS ZG-100 MOD
1	5	61-1319	WELDMENT, ZG100 ADAPTER PLATE
1	4	61-753	WELDMENT, BLOWER BOLT BAR
1	3	61-752	WELDMENT, BLOWER BOLT BAR
1	2	61-972	WELDMENT, BLOWER OUTLET
1	1	69-356	ASSY, VAC BREAK
QTY	ITEM	PART NO.	DESCRIPTION

**69-356, ASSEMBLY, VACUUM RELIEF VALVE**

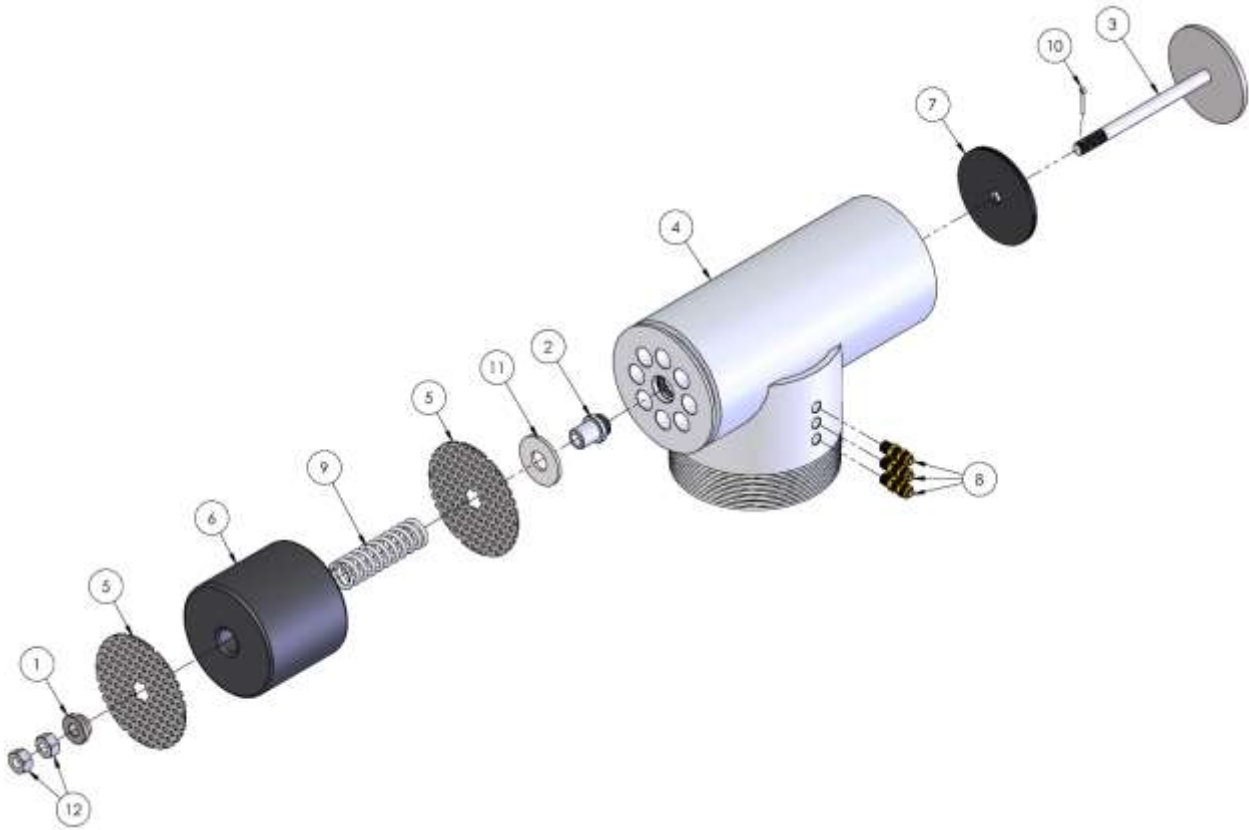

2	12	11-012	NUT, 7/16-14 ZP
1	11	12-040	WASHER, FLAT .625 USS
1	10	14-032	PIN, COTTER 7/64 X 3/4 SS
1	9	15-033	SPRING, VAC RELIEF VALVE
3	8	21-028	CONN, 1/8 P X 1/4 POLY
1	7	41-113	DIAPHRAGM, VAC RELIEF
1	6	50-019	FOAM, VAC BREAK
2	5	60-1865	WASHER, VAC BRAKE SILENCER
1	4	61-763	WELDMENT, VAC BREAK
1	3	61-768	WELDMENT, VAC RELIEF STEM
1	2	66-431	PILOT, VAC BRAKE SHAFT
1	1	66-502	BUSHING, LARGE SPRING RETAINER
QTY	ITEM	PART NO.	DESCRIPTION

**69-762, ASSEMBLY, PRESSURE PUMP**

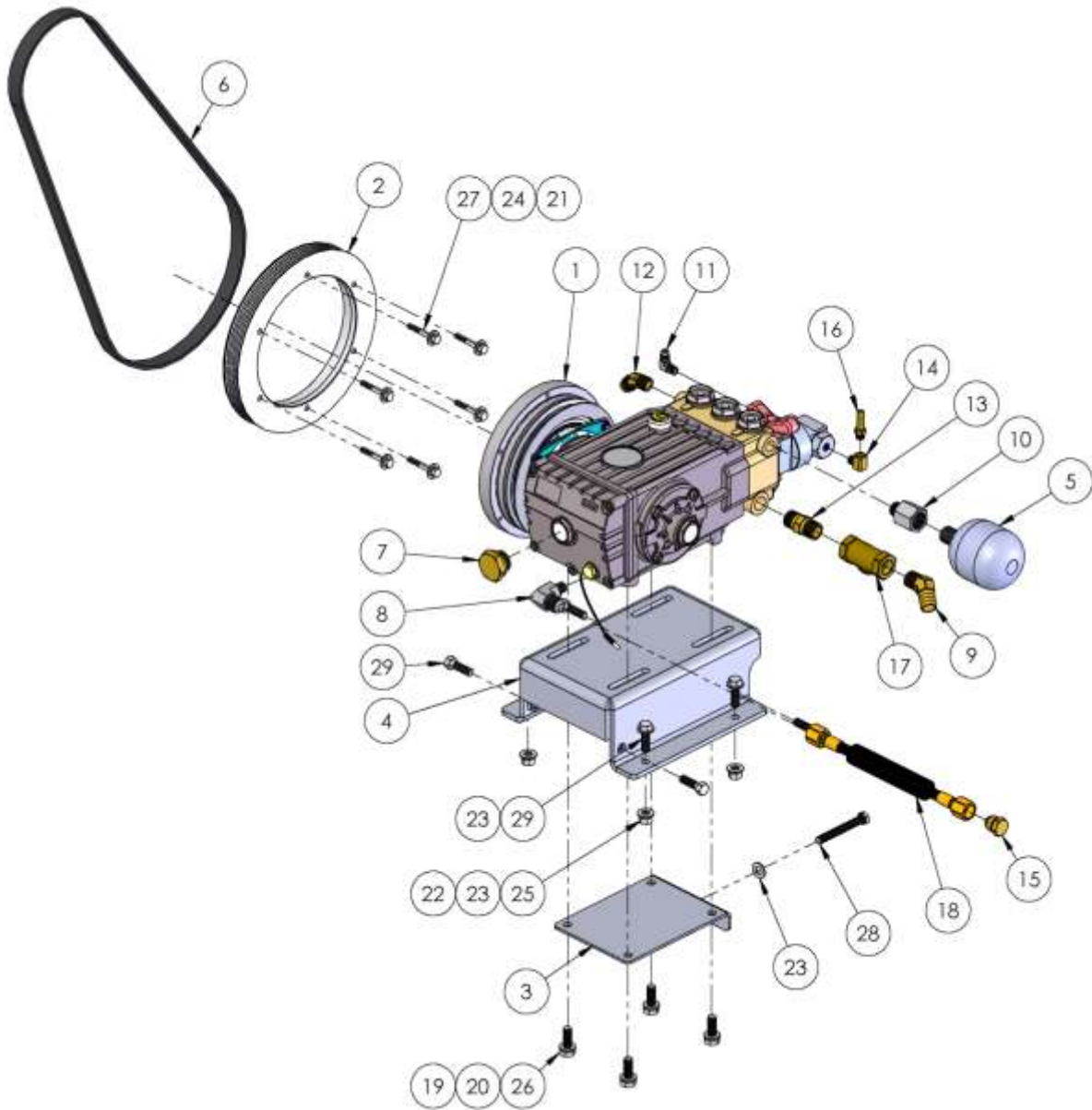

**69-762, ASSEMBLY, PRESSURE PUMP – BOM TABLE**

8	29	10-004	SCREW, MACH 3/8-16 X 1-1/4 HEXHD
1	28	10-057	BOLT, TAP 3/8-16 X 3 GR 5
6	27	10-170	SCREW, MACH, 3/8-16 X 2-3/4 HH G5
4	26	10-208	SCREW, M10-1.5 X 30MM HCS Z GR8.8
4	25	11-006	NUT, 3/8-16 ZINC
6	24	12-012	WASHER, FLAT 1/4 USS
9	23	12-013	WASHER, FLAT 3/8 SAE
4	22	12-014	LKWSR, 3/8 ZINC
6	21	12-015	LKWSR, 1/4 ZINC
4	20	12-024	LKWSR, 10MM ZINC
4	19	12-025	WASHER, FLAT M10
1	18	18-214-05	HOSE, 7/16 ID X 08 FJIC X 08 FJIC W / SS & SLEEVE
1	17	20-056	STRAINER, 1/2 WYE BRASS
1	16	21-007	FTTG, BRB 1/8 P X 5/16 H BR
1	15	21-027	PLUG, 1/2 T BR
1	14	21-038	ELL, STREET 1/8 IN BRASS
1	13	21-047	NIP, 1/2 IN HEX BRASS
1	12	21-059	ELL, 3/8 NPT X 1/2 JIC 45 DEG BRASS
1	11	21-066	ELL, 1/8 NPT X 1/4 JIC SS
1	10	21-424	ADAPTER, REDUCING 1/2 FNPT X 3/8 MNPT
1	9	21-431	ELL, 1/2P X 3/4H 45 DEG BRASS
1	8	21-444	ELL, 1/4 BSPP X 1/2 JIC STEEL
1	7	36-501	PLUG, GP OIL LEVEL
1	6	37-110	BELT, K060563 GATES MICRO-V
1	5	46-045	ACCUMULATOR, CAT 6028
1	4	61-1301	WELDMENT, PUMP BRACKET
1	3	61-733	WELDMENT, PUMP BOLT PLATE
1	2	66-345	PULLEY, PRESSURE PUMP
1	1	68-184	ASSY, PRESSURE PUMP
QTY	ITEM	PART NO.	DESCRIPTION

**69-772, ASSY, THERMAL WELL**

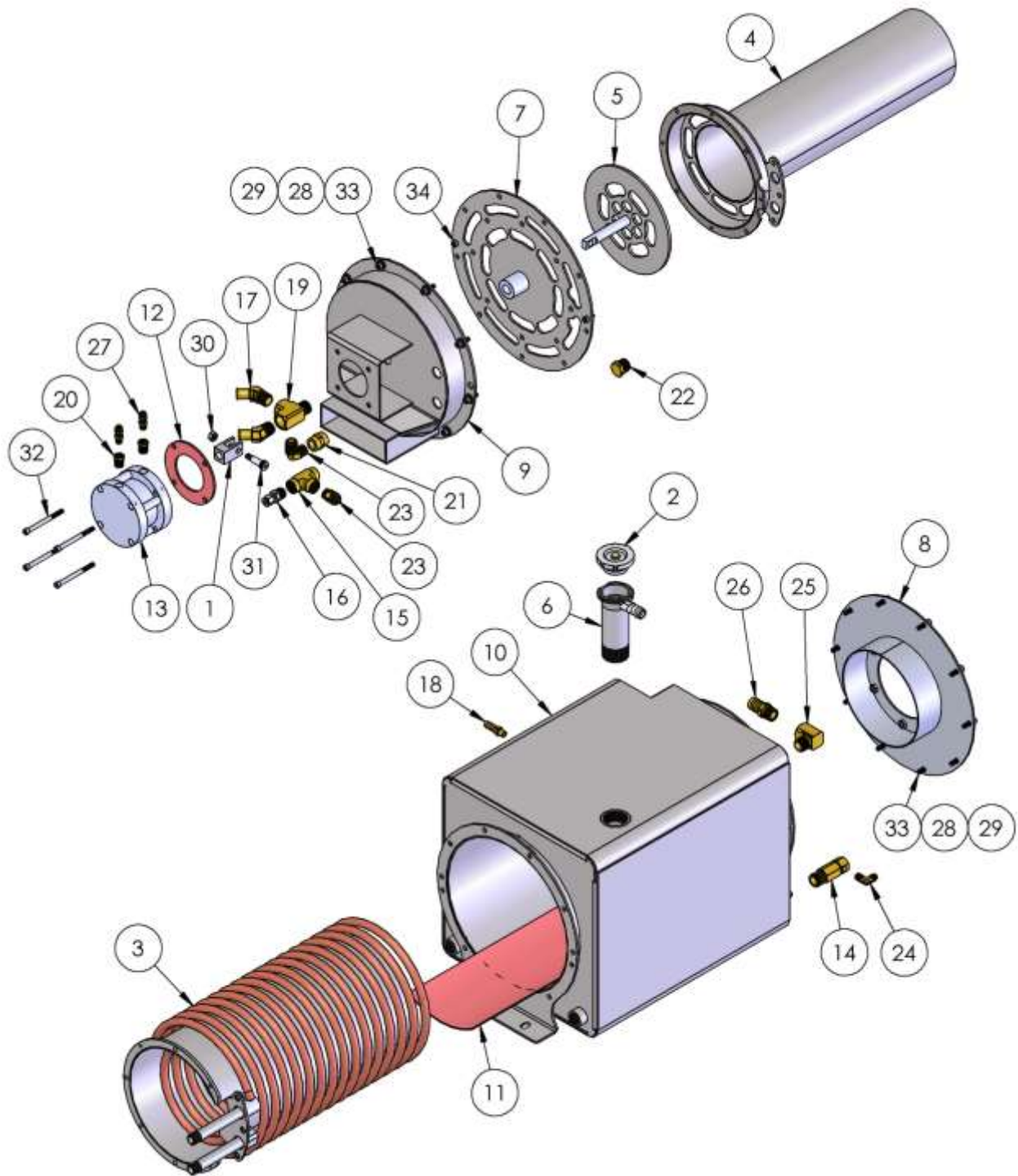



**69-772, ASSY, THERMAL WELL (BOM TABLE)**

2	34	10-007	SCREW, MACH 1/4-20 X 1/2 SOCHD SS
19	33	10-021	SCREW, MACH 1/4-20 X 3/4 SOCHD SS
4	32	10-143	BOLT, 1/4-20 X 3 SHCS ZP
1	31	10-234	BOLT, 3/8 X 7/8 SHOULDER 5/16-18 THD
1	30	11-090	NUT, 5/16-18 TOPLOCK GRC Z
19	29	12-002	WASHER, FLAT 1/4 SS ANC
19	28	12-003	LKWSR, 1/4 IN SS
2	27	21-028	CONN, 1/8 P X 1/4 POLY
1	26	21-032	FTTG, BRB 1/2 P X 3/4 H BRASS
1	25	21-034	ELL, STREET 1/2 BRASS
1	24	21-054	ELL, 1-8P X 1-4 T BRASS
2	23	21-061	ELL, 3/8 P X 1/2 T BRASS
1	22	21-065	PLUG, 1/2 NTP SOLID BRASS HXHD
1	21	21-073	COUPLING, 3/8 NPT BRASS
2	20	21-076	BUSHING, 1/4 M X 1/8 F BRASS
1	19	21-111	TEE, STREET 1/2 NPT BRASS
1	18	21-170	FTTG, BARB 1/8 MNPT X 3/8 H BRASS
2	17	21-324	ELL, 1/2P X 5/8H 45 DEG BRASS
1	16	21-500	FTTG, 3/8 NPT X 1/4 COMPRESSION SS
1	15	21-501	TEE, 3/8 NPT HI PRESSURE BRASS
1	14	23-033	VALVE, 165 DEG THERMAL CAT 7145
1	13	23-067	CYLINDER, AIR, BIMBA FO-701.5-CMTV
1	12	41-069	GASKET, DIVERTER CYLINDER
1	11	41-092	GASKET, 5-13/16 X 17 X .062 SILICONE SHT W/PSA
1	10	61-1302	WELDMENT, THERMAL WELL
1	9	61-1356	WELDMENT, DIVERTER COVER
1	8	61-1372	WELDMENT, INLET ADAPTER
1	7	61-1375	WELDMENT, DIVERTER HOUSING PLATE
1	6	61-1377	WELDMENT, FILLER NECK
1	5	61-530	WELDMENT, DIVERTER PLATE
1	4	61-531	WELDMENT, DIVERTER CHAMBER
1	3	61-532	WELDMENT, FINNED TUBE COIL
1	2	63-182	CAP, RADIATOR 23LB
1	1	66-211	.875 SQ CLEVIS WITH 5E-11 THREAD
QTY	ITEM	PART NO.	DESCRIPTION

**69-815, ASSEMBLY, COOLANT HEAT EXCHANGER**

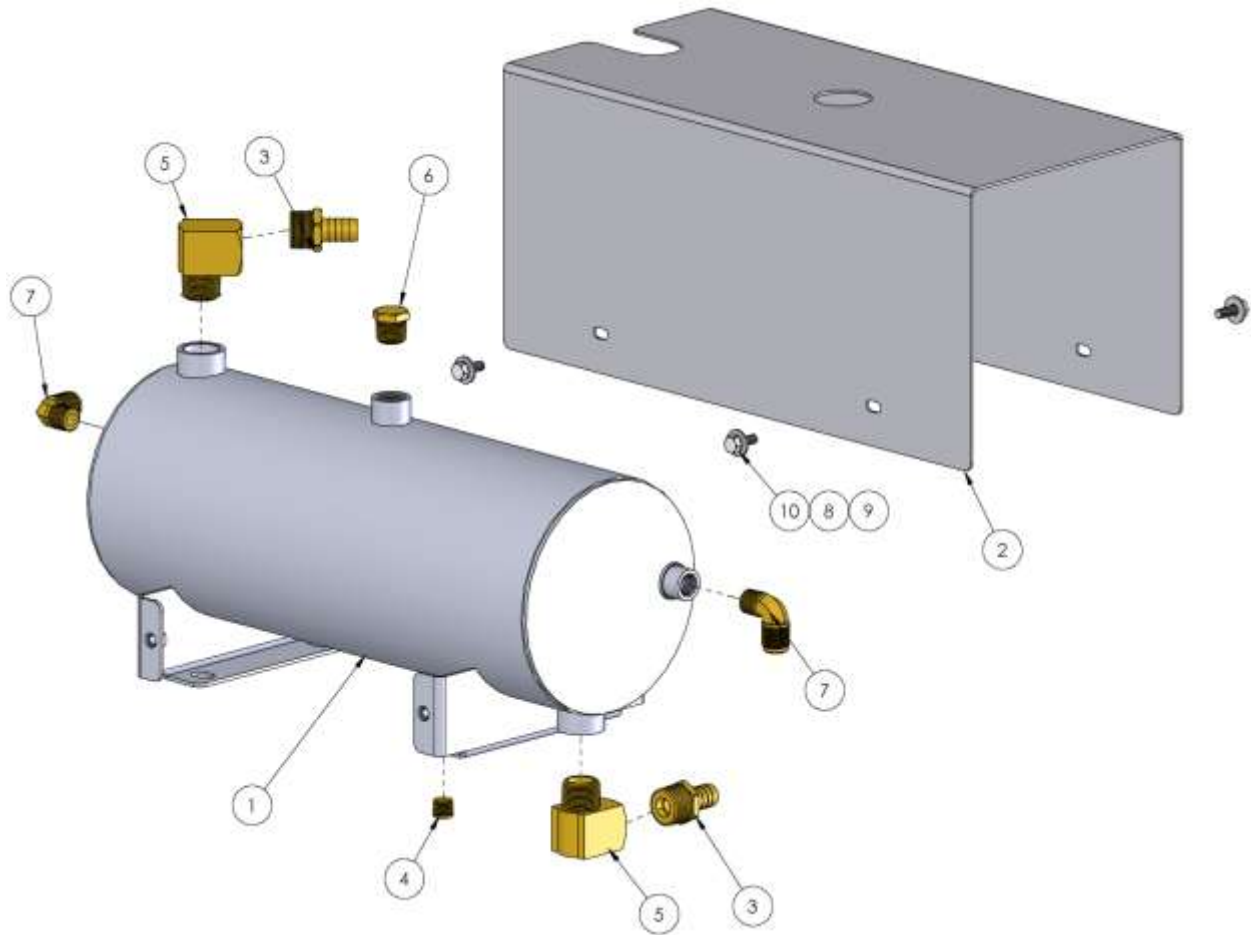

4	10	10-020	SCREW, MACH 1/4-20 X 3/4 HXHD SS
4	9	12-012	WASHER, FLAT 1/4 USS
4	8	12-015	LKWSR, 1/4 ZINC
2	7	21-061	ELL, 3/8 P X 1/2 T BRASS
1	6	21-065	PLUG, 1/2 NTP SOLID BRASS HXHD
2	5	21-585	ELBOW, STREET 3/4 NPT BRASS
1	4	21-264	PLUG, 1/4 NPT BRASS
2	3	21-408	FTG, BARB 3/4 P X 5/8 H BRASS
1	2	60-2933	PANEL, HEAT EXCHANGER COVER
1	1	61-1371	WELDMENT, COOLANT HEAT EXCH
QTY	ITEM	PART NO.	DESCRIPTION

**69-766, ASSEMBLY, EXHAUST, CATALYST AND SILENCER**

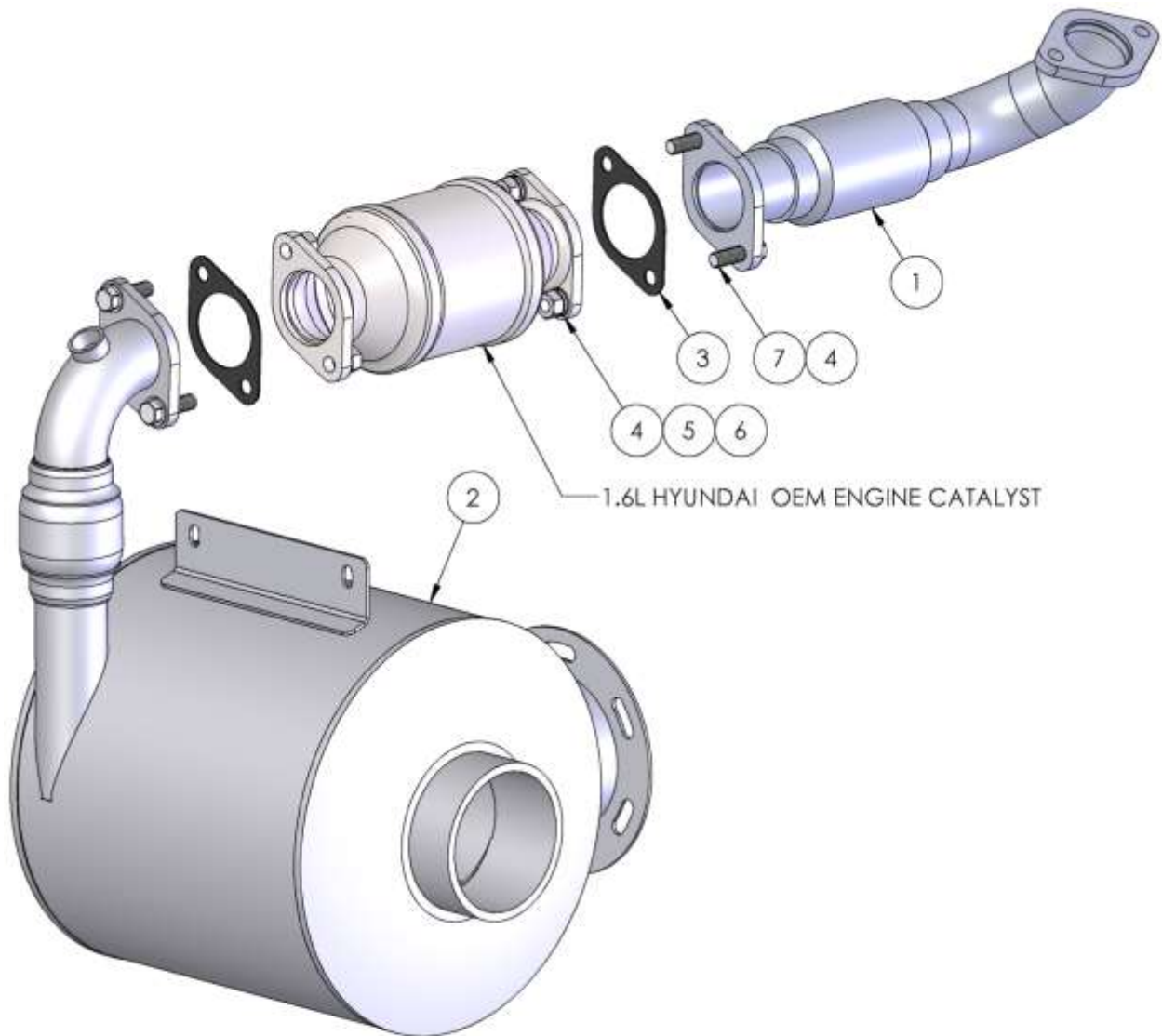

4	7	10-039	SCREW, MACH 7/16-14 X 1-1/2 HXHD
4	6	11-012	NUT, 7/16-14 ZP
4	5	12-020	LKWSR, 7/16 ZINC
8	4	12-013	WASHER, FLAT 3/8 SAE
2	3	36-520	GASKET, EXHAUST 1.6L HYUNDAI
1	2	61-1291	WELDMENT, SILENCER
1	1	61-1292	WELDMENT, EXHAUST TUBE ENGINE
QTY	ITEM	PART NO.	DESCRIPTION

**69-822, ASSEMBLY, BYPASS COOLER**

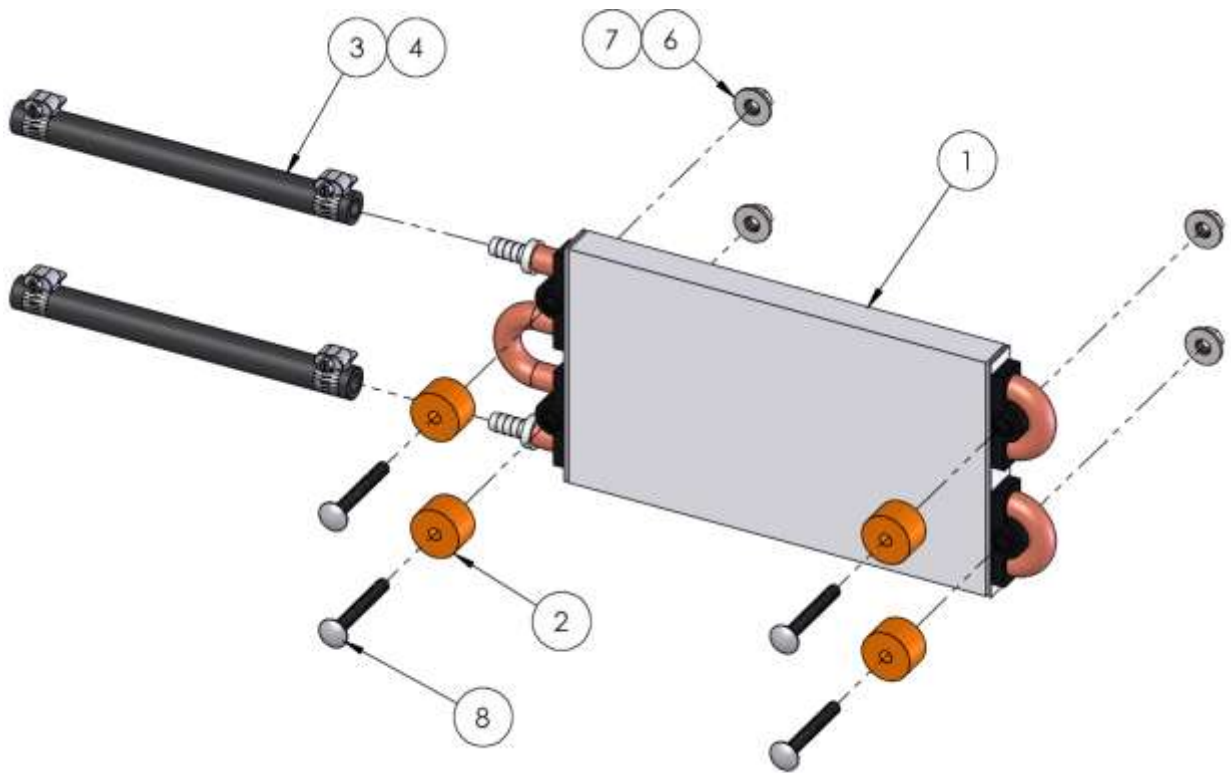

4	8	10-384	SCREW, CARRIAGE 1/4-20 X 2 ZP
4	7	11-004	NUT, 1/4-20 ZINC
4	6	12-012	WASHER, FLAT 1/4 USS
4	5	12-015	LKWSR, 1/4 ZINC
4	4	14-007	CLAMP, HOSE #4
4 FT	3	16-033	HOSE, 3/8 IN 300PSI INSTA GRIP
0.5	2	41-144	ISOLATOR, 1.00 OD X .25 ID X 6 LG SILCONE
1	1	63-242	COOLER, FINNED TUBE
QTY	ITEM	PART NO.	DESCRIPTION

**69-818, ASSEMBLY, CRANK VENT ADAPTER**

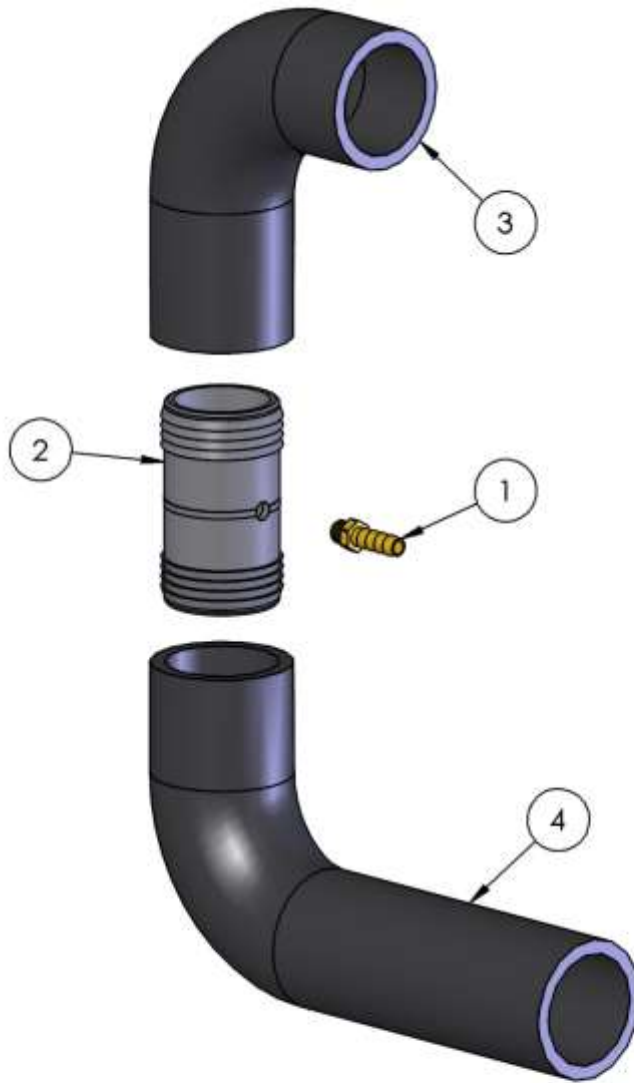

1	4	36-401	HOSE, RADIATOR 1.00 ID NAPA 8205
1	3	36-401	HOSE, RADIATOR 1.00 ID NAPA 8205
1	2	21-003	FTTG, BRB 2 IN H BS PVC
1	1	21-007	FTTG, BRB 1/8 P X 5/16 H BR
QTY	ITEM	PART NO.	DESCRIPTION

**69-789, ASSEMBLY, MANIFOLD BLOCK AND BYPASS**

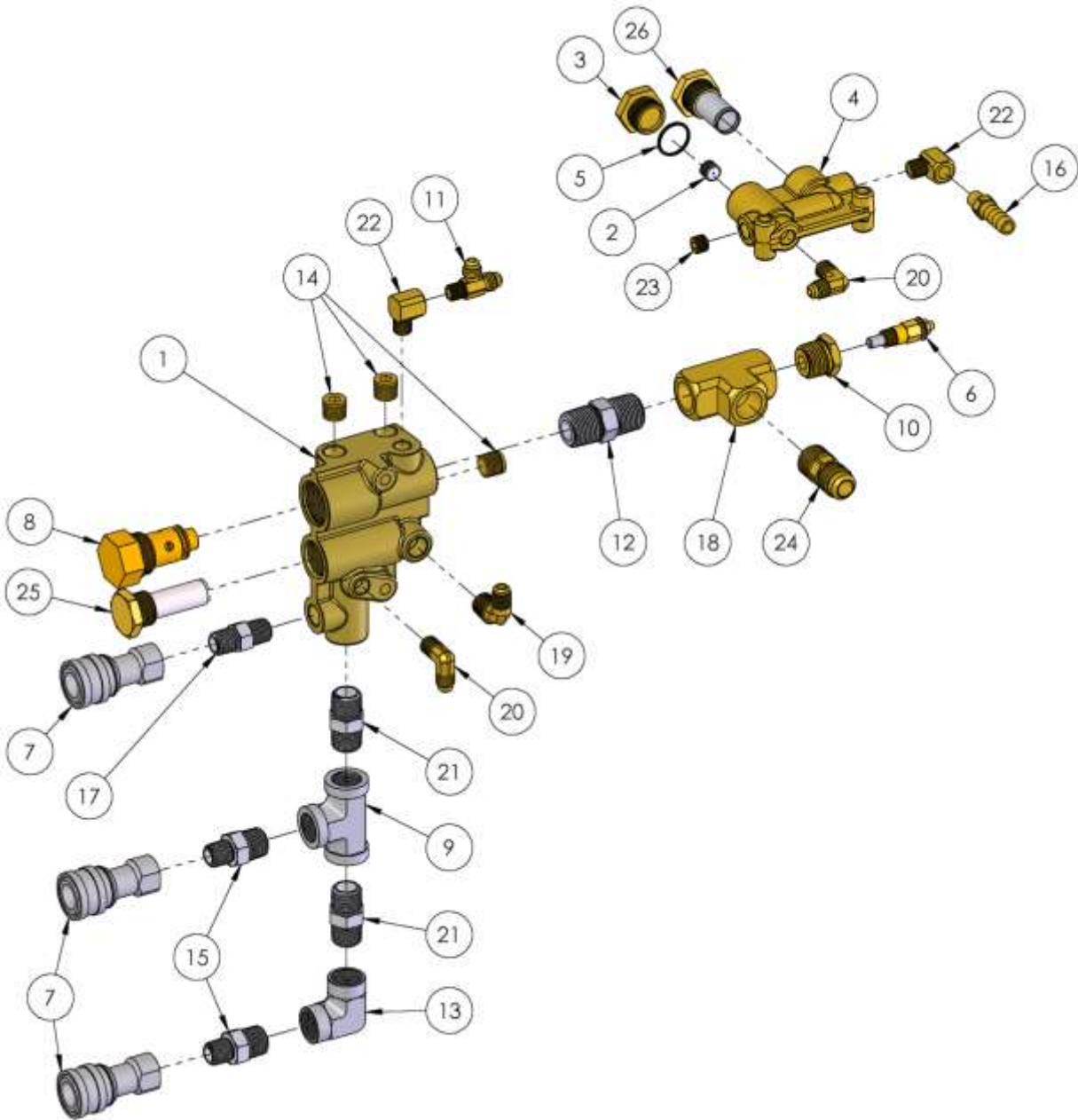

**69-789, ASSEMBLY, MANIFOLD BLOCK AND BYPASS – BOM TABLE**

1	26	20-015	SCREEN, BYPASS MANIFOLD
1	25	20-018	SCREEN, CHECK VALVE MANIFOLD
1	24	21-012	CONN, 1/2 NPT X 1/2 T BRASS
1	23	21-029	PLUG, 1/8 NPT SOCKET HD BRASS
2	22	21-038	ELL, STREET 1/8 IN BRASS
2	21	21-053	NIPPLE, HEX 3-8 NPT SS
2	20	21-054	ELL, 1-8P X 1-4 T BRASS
1	19	21-064	ELL, 1/4 P X 1/4 T BRASS
1	18	21-110	TEE, 1/2 NPT BRASS
1	17	21-128	NIPPLE, HEX 1/4 NTP SS
1	16	21-170	FTTG, BARB 1/8 MNPT X 3/8 H BRASS
2	15	21-231	NIPPLE, 1/4 X 3/8 SS NPT
3	14	21-264	PLUG, 1/4 NPT BRASS
1	13	21-294	ELL, 3/8 NPT SS
1	12	21-295	NIP, HEX 1/2 NPT SS
1	11	21-336	TEE, RUN 1/8 NPT X 1/4 JIC X 1/4 JIC BRASS
1	10	21-373	BUSHING, 1/2 NPT X 1/8 FNPT BRASS
1	9	21-412	TEE, 3-8 NTP SS
1	8	23-063	CHECK VALVE MANIFOLD
3	7	25-013	DSC, 1/4 X 1/4 FP STAINLESS
1	6	34-000	SENER, TEMP, 140-320 DEGREE
1	5	41-003	ORING, .676 ID .816 OD
1	4	66-011	MANIFOLD, BYPASS
1	3	66-017	CAP, CHECK VALVE
1	2	66-020	ORFICE, BYPASS MANIFOLD, .037 GREEN
1	1	66-205	MANIFOLD BLOCK
QTY	ITEM	PART NO.	DESCRIPTION

**69-775, ASSEMBLY, QD BRACKET**

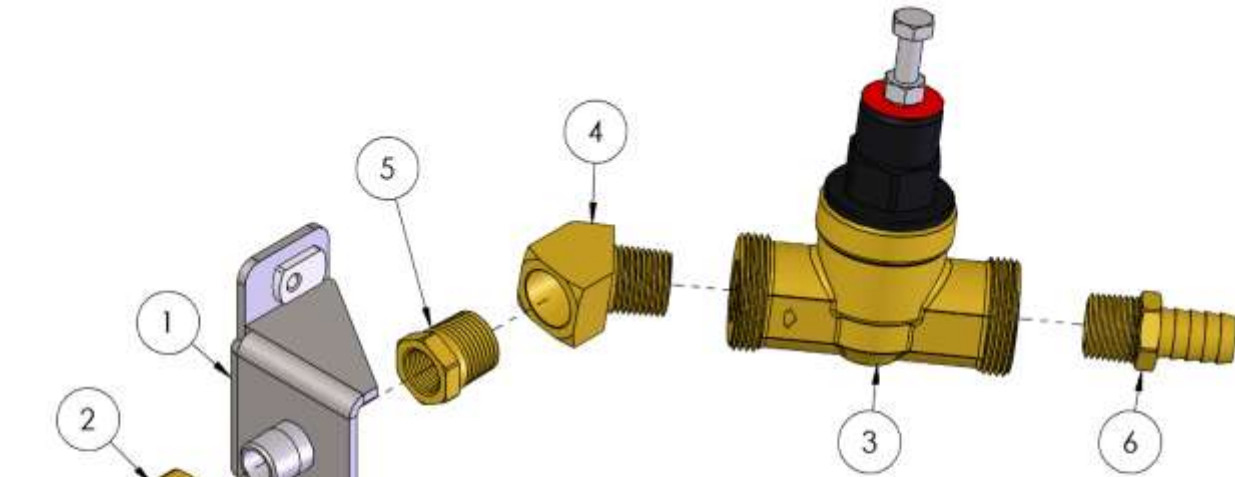

1	6	21-109	FTTG, 1/2 NPT X 5/8 BARB BRASS
1	5	21-371	BUSHING, 1/2 NPT X 3/8 NPT HEX BRASS
1	4	21-044	ELL 1/2 NPT, 45 DEG BRASS
1	3	23-085	REGULATOR, PRESSURE EB-45 1/2 NTP PRESET
1	2	25-005	QUICK COUPLING, 3/8 F X 3/8 FNPT BRASS
1	1	61-507	WELDMENT, BRACKET QD MOUNTING
QTY	ITEM	PART NO.	DESCRIPTION



**69-790, ASSEMBLY, PRESSURE REGULATOR**

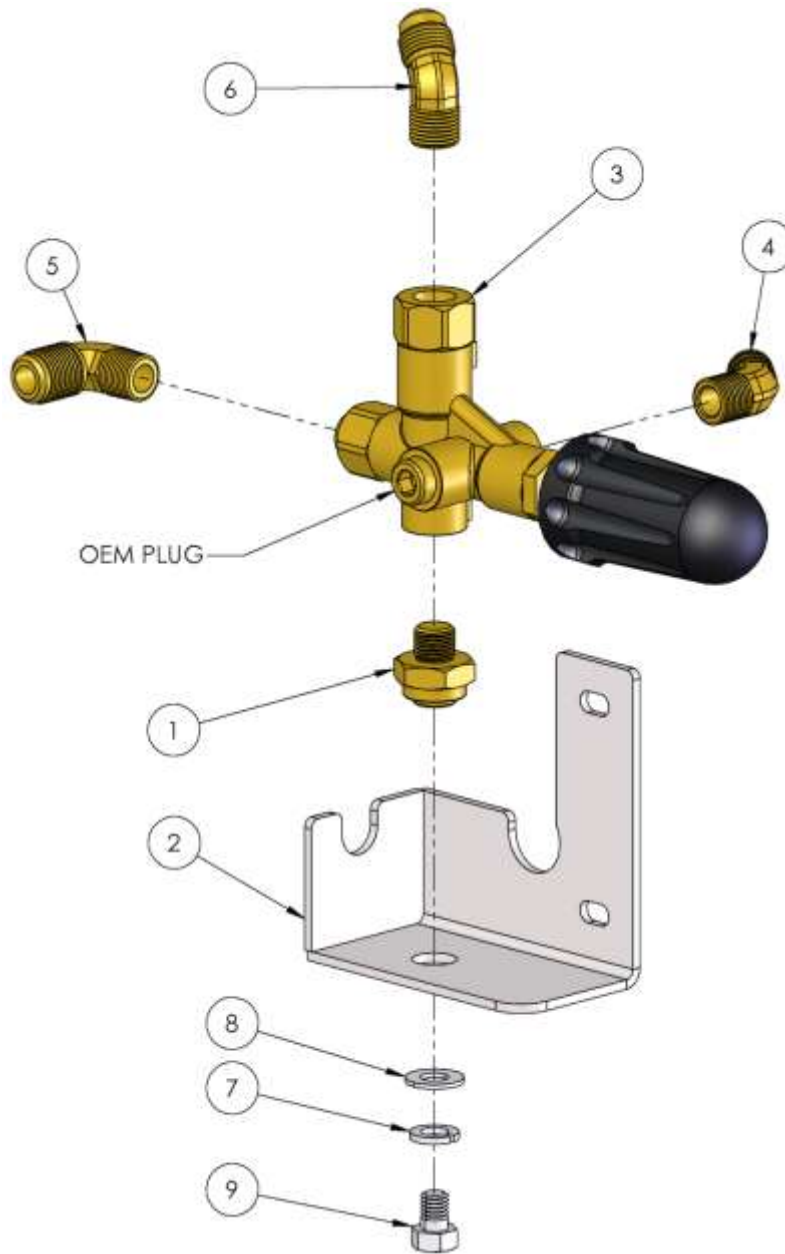

1	9	10-157	SCREW, MACH 3/8-16 X 1/2 HH ZP
1	8	12-013	WASHER, FLAT 3/8 SAE
1	7	12-014	LKWSR, 3/8 ZINC
1	6	21-059	ELL, 3/8 NPT X 1/2 JIC 45 DEG BRASS
1	5	21-061	ELL, 3/8 P X 1/2 T BRASS
1	4	21-413	FTTG, BARB 45 DEG 3-8P X 5-8H
1	3	23-107	REG, PRESSURE PULSAR4
1	2	61-1108	WELDMNT, REGULATOR BRACKET
1	1	66-340	FITTING, 3/8 NPT M X 3/8-16 F STANDOFF
QTY	ITEM	PART NO.	DESCRIPTION

**69-792, ASSEMBLY, OIL CUP AND BYPASS VALVE**

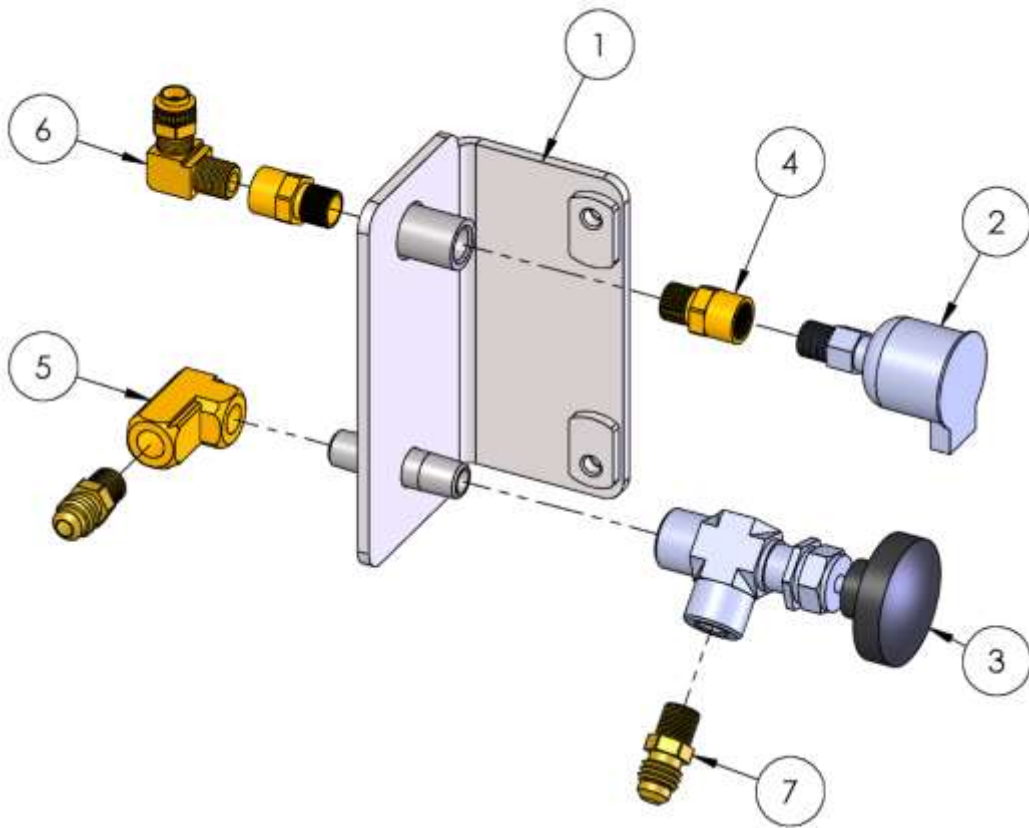

2	7	21-001	CONN, 1/8 P X 1/4 T BR
1	6	21-011	ELL, 1/8 NPT X 1/4 POLY BRASS
1	5	21-090	ELL, 1/8 FNPT X 1/8 FNPT BRASS
2	4	21-333	COUPLING, 1/8 FNPT X 1/8 MNPT BRASS
1	3	23-118	VALVE, METERING 1/8FP RT ANGLE SS
1	2	28-000	CUP, OILFILL, 1/8 NPT
1	1	61-1381	WELDMENT, OIL & BYPASS BRKT
QTY	ITEM	PART NO.	DESCRIPTION

**69-402, ASSEMBLY, 870H RECOVERY TANK**

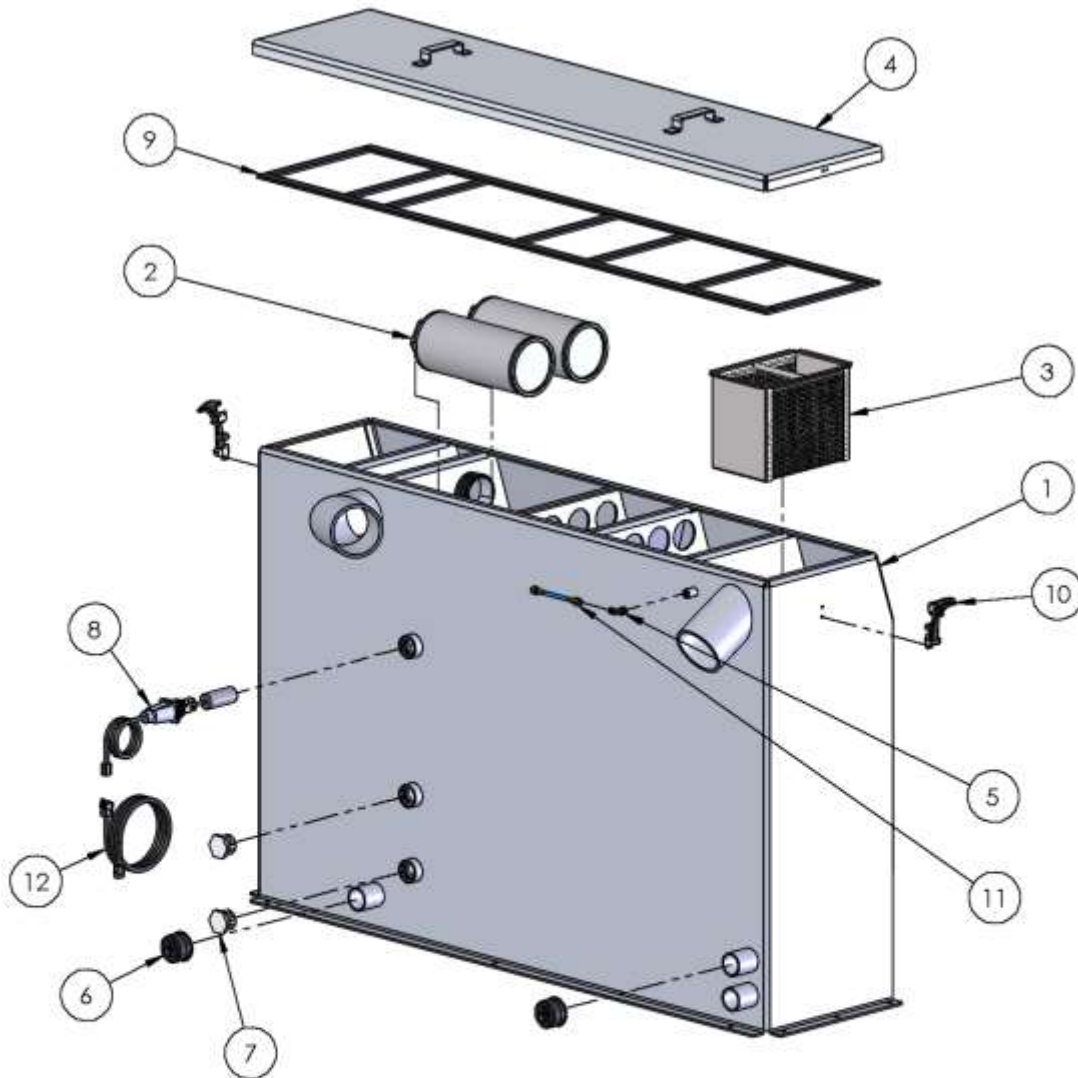

1	12	47-095	HARNES, LEVEL SENSOR EXTENSION
1	11	18-215-16	HOSE ASSEMBLY, 3-16 ID X 38 OL
2	10	40-003	LATCH, PRE-FILTER BOX
199 IN	9	41-018	GASKET, SPONGE 1 IN X 45 FT
1	8	69-000	FLOAT SWITCH
2	7	21-097	PLUG, 1-1/4 IN PVC
2	6	19-009	CAP, 2 IN RUBBER
1	5	21-064	ELL, 1/4 P X 1/4 T BRASS
1	4	61-672	WELDMENT, LID LARGE RECOVERY TANK
1	3	61-002	WELDMENT, STRAINER BASKET
2	2	20-021	STRAINER, FILTER 3" 100 MESH
1	1	61-794	WELDMENT, 4500 RECOVERY TANK
QTY	ITEM	PART NO.	DESCRIPTION

**DECALS**



**ELECTRICAL SHOCK  
COULD CAUSE SEVERE  
BURNS OR INJURY. DO  
NOT TOUCH ELECTRICAL  
WIRES OR COMPONENTS  
WHILE THE ENGINE IS  
RUNNING. DISCONNECT  
THE BATTERY BEFORE  
SERVICING THIS UNIT TO  
PREVENT ACCIDENTAL  
STARTING.**

44-066 A

44-066, WARNING,  
ELECTRICAL SHOCK



**READ THE OPERATOR'S MANUAL  
BEFORE INSTALLING OR  
STARTING THIS UNIT. FAILURE TO  
ADHERE TO INSTRUCTIONS CAN  
RESULT IN SEVERE PERSONAL  
INJURY OR COULD BE FATAL.  
REPLACEMENT  
MANUALS CAN BE PURCHASED  
FROM:  
Sapphire Scientific  
2804 Liberator  
Prescott, AZ 86301**

44-067 A

44-067, WARNING,  
READ MANUAL



**ROTATING MACHINERY  
CAN CAUSE INJURY OR  
COULD BE FATAL.  
KEEP ALL GUARDS  
AND SAFETY DEVICES  
IN PLACE.**

44-085 A

44-085, WARNING,  
ROTATING MACHINERY



44-084, CAUTION, HOT  
SURFACE

**ROTATING  
MACHINERY.  
WATER UNDER  
PRESSURE AT HIGH  
TEMPERATURE.  
IMPROPER  
MODIFICATION OF  
EQUIPMENT CAN  
CAUSE SEVERE  
PERSONAL INJURY  
OR COULD BE  
FATAL.**

44-082, DANGER, ROTATING MACHINERY



**DO NOT MODIFY  
UNIT WITHOUT  
WRITTEN  
PERMISSION  
FROM  
MANUFACTURER**

44-082 A

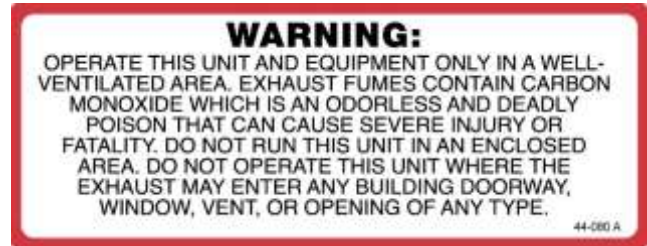

**WARNING:**  
OPERATE THIS UNIT AND EQUIPMENT ONLY IN A WELL-  
VENTILATED AREA. EXHAUST FUMES CONTAIN CARBON  
MONOXIDE WHICH IS AN ODORLESS AND DEADLY  
POISON THAT CAN CAUSE SEVERE INJURY OR  
FATALITY. DO NOT RUN THIS UNIT IN AN ENCLOSED  
AREA. DO NOT OPERATE THIS UNIT WHERE THE  
EXHAUST MAY ENTER ANY BUILDING DOORWAY,  
WINDOW, VENT, OR OPENING OF ANY TYPE.

44-080 A

44-080, WARNING, VENTILATED AREA



44-127, DECAL, PRODUCT 870H



44-187, DECAL, CO DANGER



44-277, DECAL MOMENTARY PUMP OVERRIDE

## SECTION SIX: REFERENCE GUIDES

<b>WATER FLOW DIAGRAM.....</b>	<b>98</b>
<b>CHEMICAL FLOW DIAGRAM.....</b>	<b>99</b>
<b>WIRING DIAGRAM.....</b>	<b>100</b>
<b>FUEL LINE INSTALLATION</b>	
1992 – 2002 FORD .....	101
CHEVY / GMC FULL-SIZE VAN.....	102
2003 CHEVY / GMC FULL-SIZE VAN.....	103
1997 – 2002 DODGE FULL-SIZE VAN .....	104
FUEL LINE BULKHEAD INSTALLATION .....	105
FUEL PUMP ASSEMBLY INSTALLATION .....	106
FUEL SUPPLY AND RETURN LINE INSTALLATION .....	107
<b>ENGINE DIAGNOSTIC CODES .....</b>	<b>108</b>

## WATER FLOW DIAGRAM

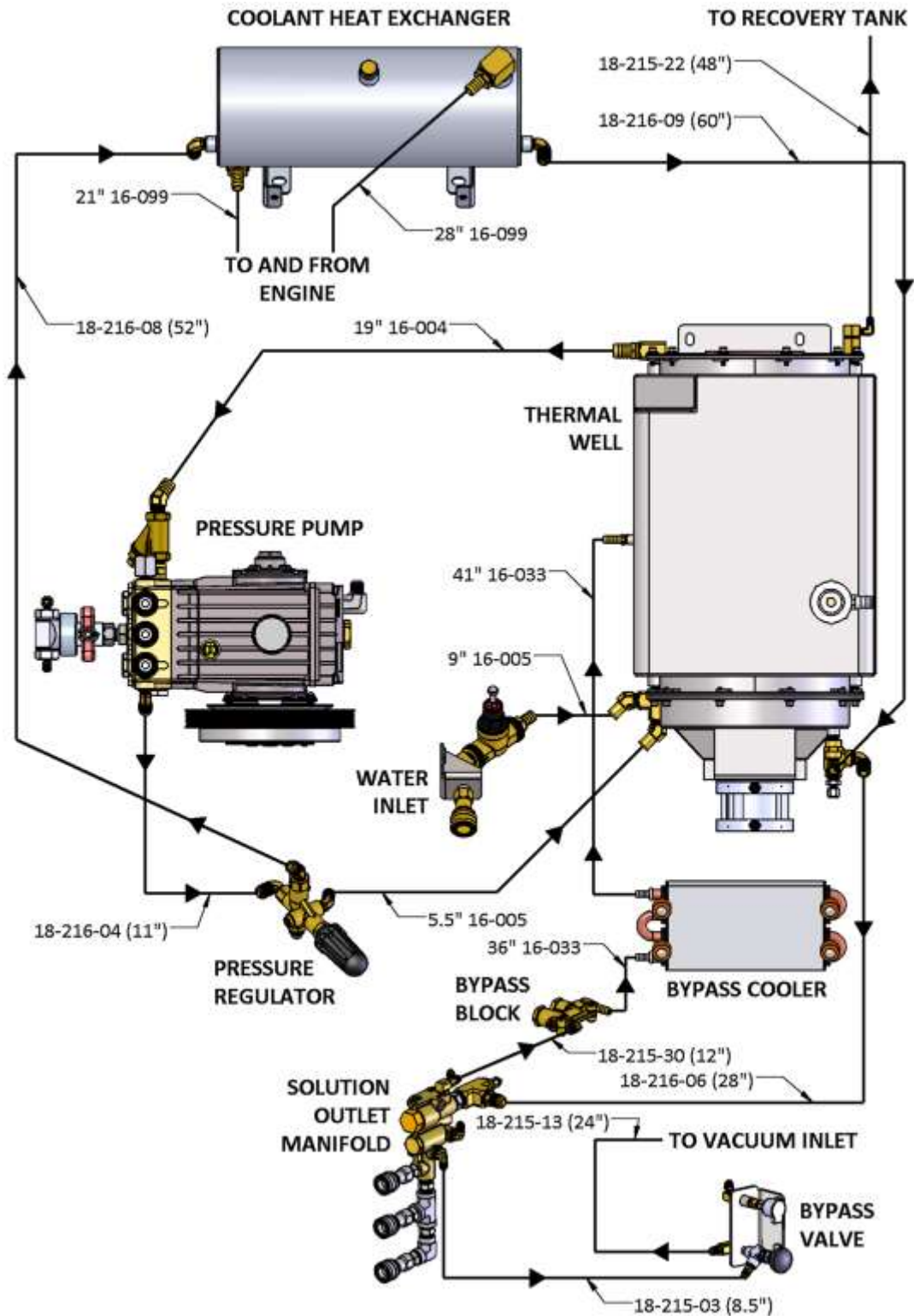

## CHEMICAL FLOW DIAGRAM

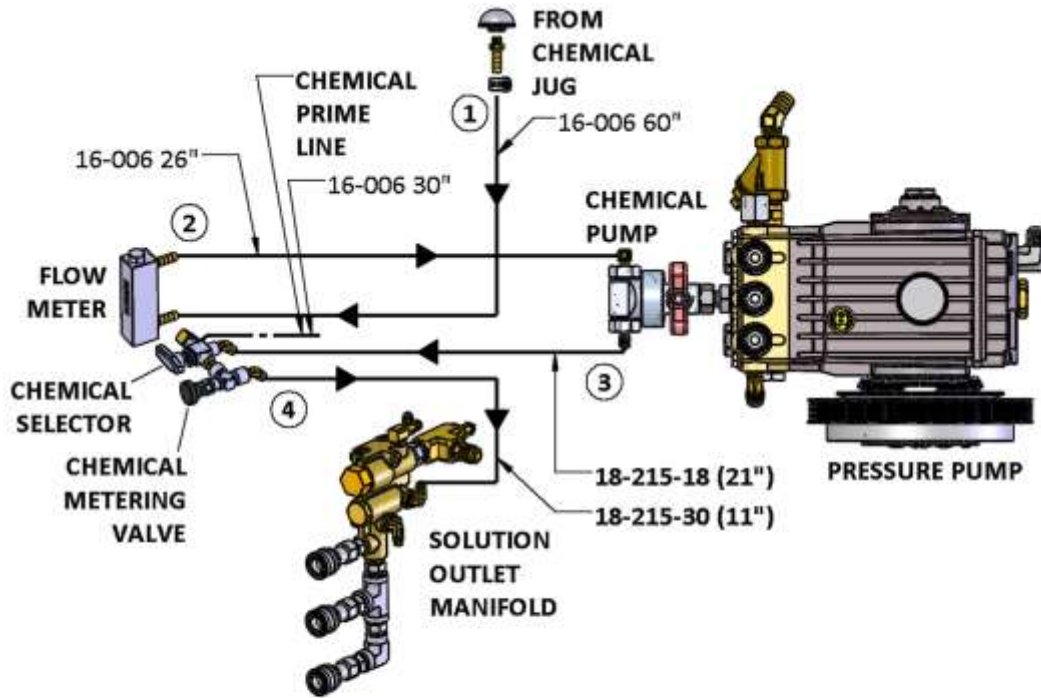

1. CHEMICAL FLOWING FROM THE CHEMICAL IS MEASURED IN THE FLOW METER
2. FROM THE FLOW METER IT TRAVELS TO THE CHEMICAL PUMP
3. CHEMICAL FLOWS FROM THE PUMP TO THE SELECTOR VALVE
4. THE AMOUNT OF CHEMICAL IS DETERMINED BY THE METERING VALVE AS IT IS SENT TO THE SOLUTION OUTLET MANIFOLD WHERE IT IS INJECTED INTO THE WATER STREAM

## WIRING DIAGRAM

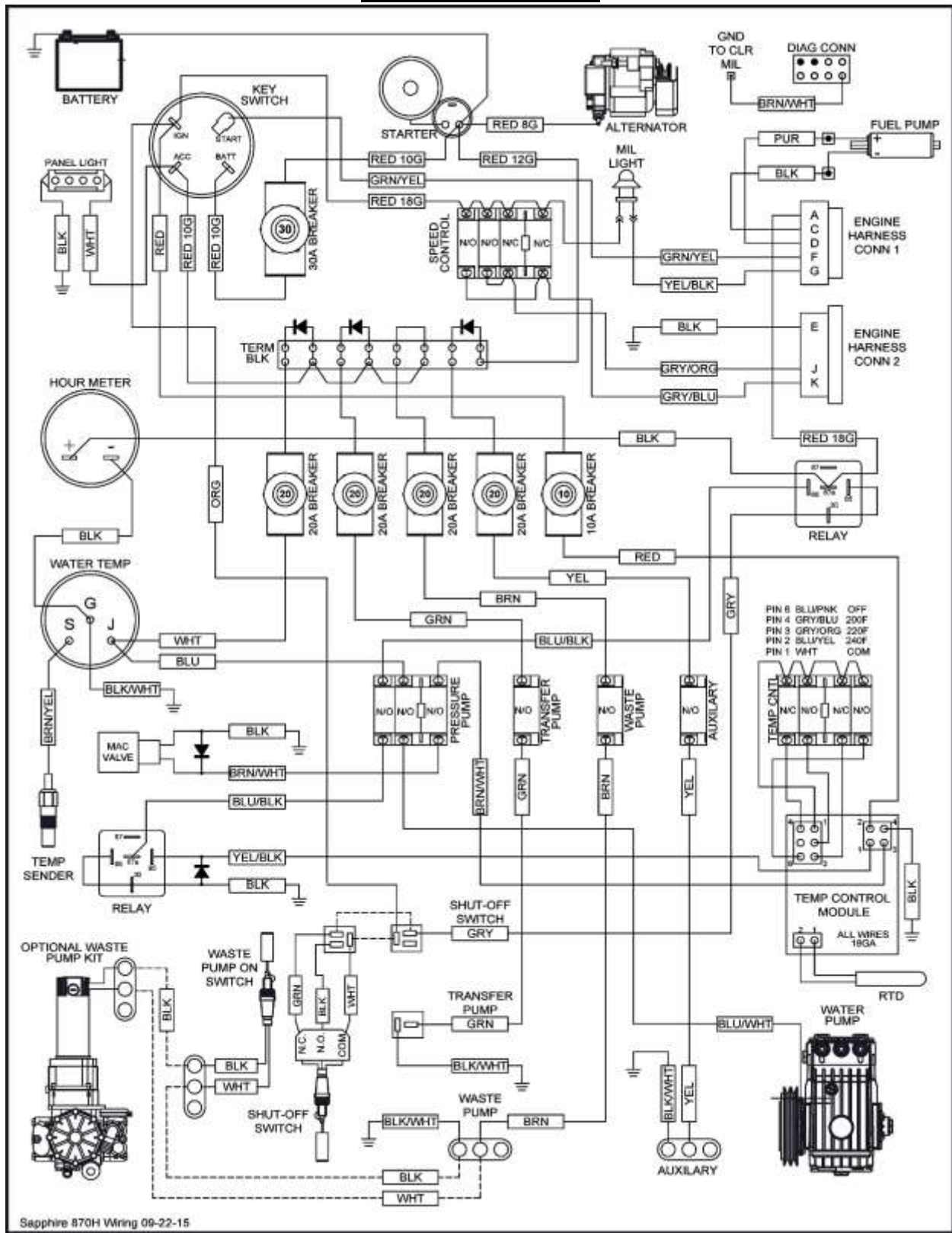



## 1992 TO 2002 FORD FUEL LINE INSTALLATION

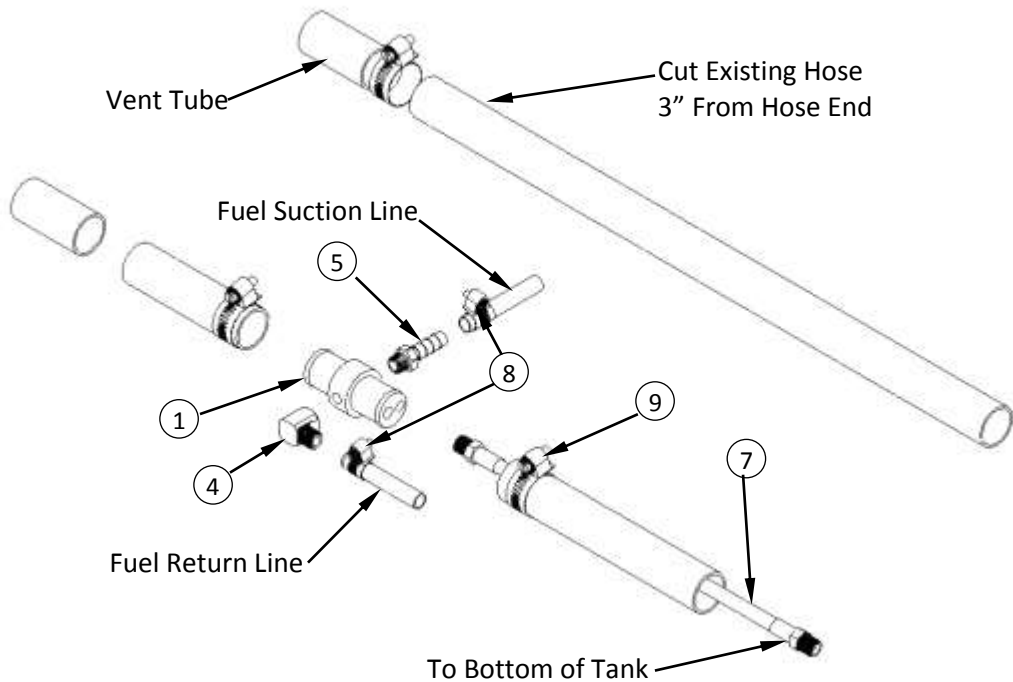

### 69-005FI KIT, FUEL HOOKUP FORD FI

Item No.	Part Number	Qty	Description
1	66-031	1	ADAPTOR, VENT TUBE(FORD)
2	21-086	2	FTTG, BULKHEAD 1/4 IN BRASS
3	21-039	2	ELL, 1/4 IN LG STREET BRASS
4	21-038	1	ELL, STREET 1/8 IN BRASS
5	21-007	2	FTTG, BRB 1/8P X 5/16 H BR
6	21-006	4	FTTG, BRB 1/4P X 5//16H BR
7	18-028	1	HOSE, 3/16 X 25 (1/8P X 1/8P NO COVER)
8	14-011	6	CLAMP, HOSE FUEL # 6
9	14-000	2	CLAMP, HOSE #12

## CHEVY AND GMC FULL SIZE VAN FUEL LINE INSTALLATION

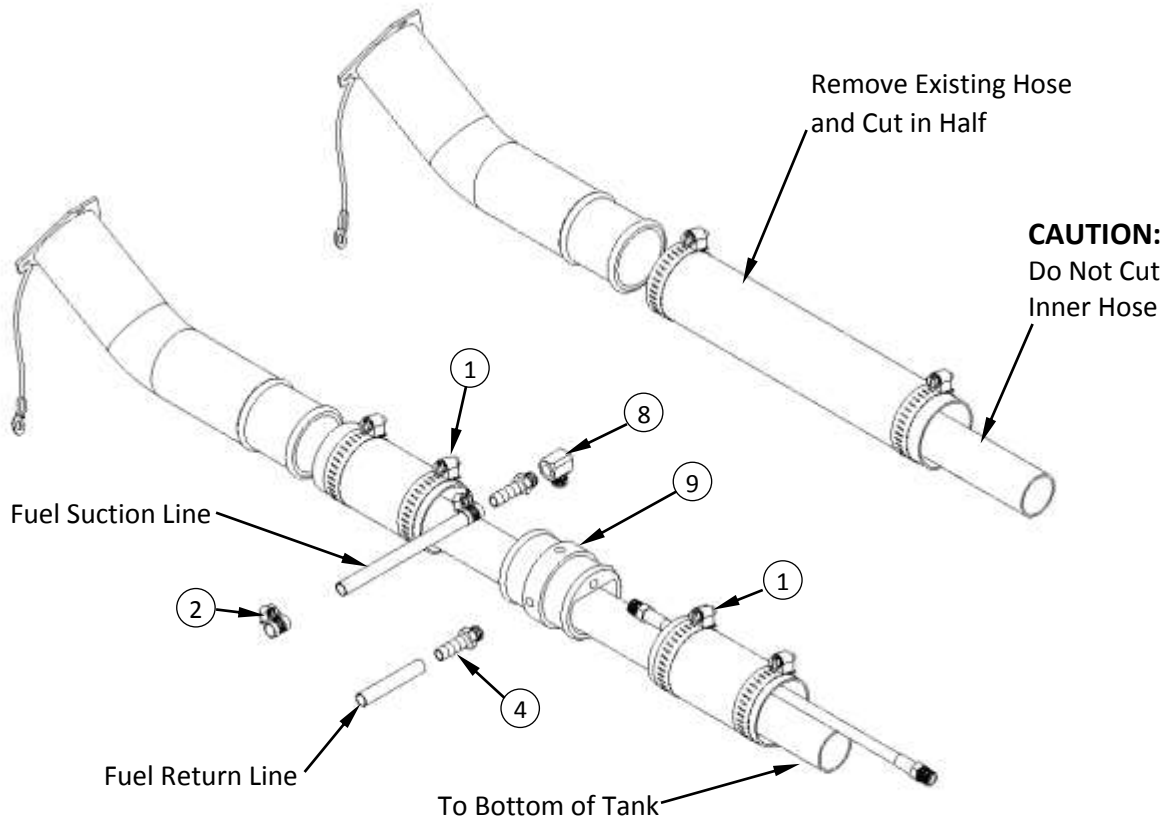

### 69-003FI KIT, FUEL HOOKUP 97 & 2002 FI

Item No.	Part Number	Qty	Description
1	14-010	2	CLAMP, HOSE # 32
2	14-011	6	CLAMP, HOSE FUEL # 6
3	21-006	4	FTTG, BRB 1/4P X 5//16H BR
4	21-007	2	FTTG, BRB 1/8P X 5/16 H BR
5	21-038	1	ELL, STREET 1/8 IN BRASS
6	21-039	2	ELL, 1/4 IN LG STREET BRASS
7	21-086	2	FTTG, BULKHEAD 1/4 IN BRASS
8	21-116	1	ELL, 1/8 FP X 1/8 FP BRONZE
9	66-030	1	ADAPTOR, FUEL NECK (CHEVY)
10	18-027	2	HOSE, 3/16 X 5 (1/8P X 1/8P NO CVR)

## 2003 CHEVY AND GMC FULL SIZE VAN FUEL LINE INSTALLATION

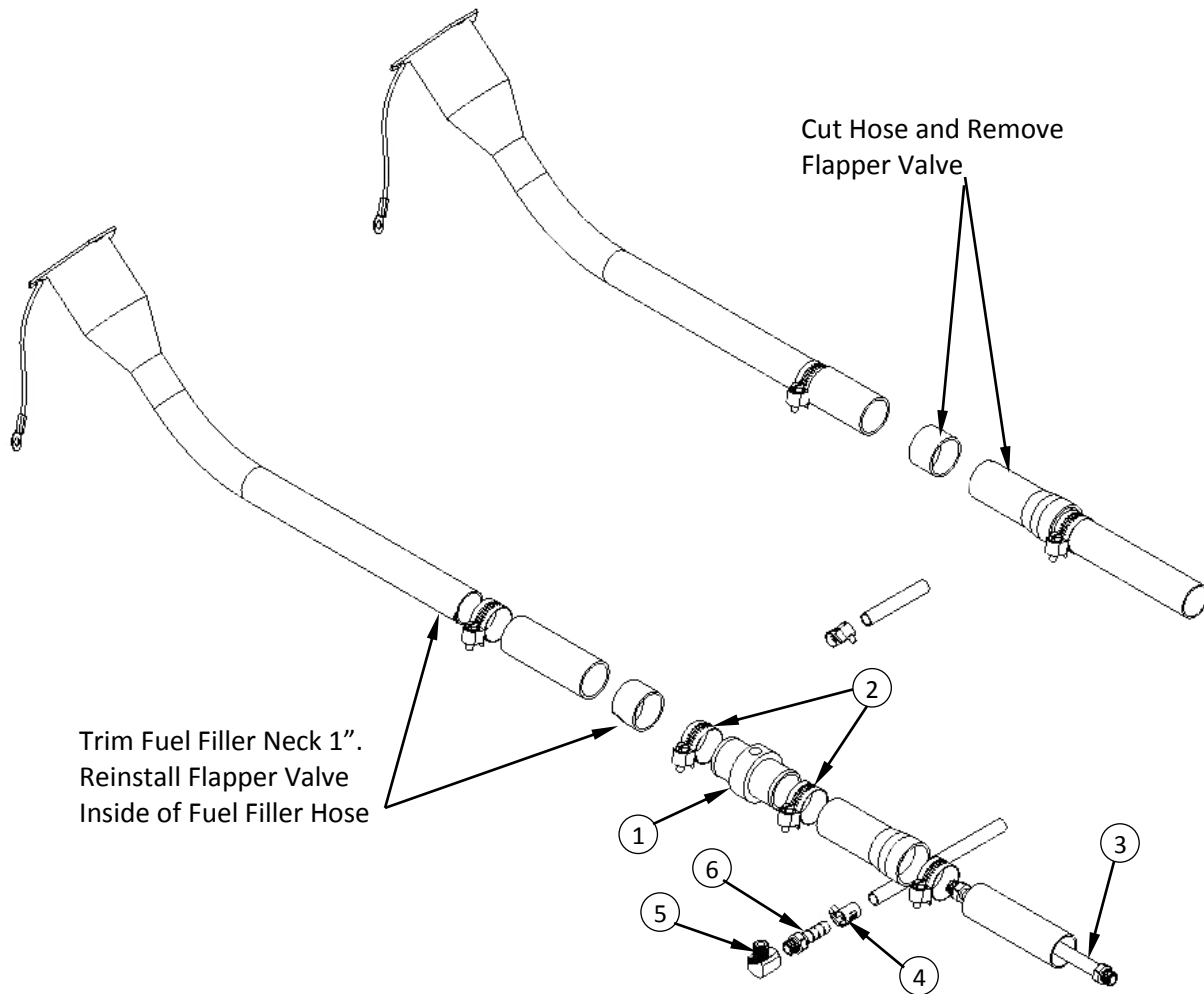

### 69-018FI KIT, FUEL HOOKUP 2003 CHEVY FI

Item No.	Part Number	Qty	Description
1	66-034	1	ADAPTOR, FUEL FLR CHVY 2003
2	14-006	2	CLAMP, HOSE # 20
3	18-028	1	HOSE, 3/16 X 25 (1/8P X 1/8P NO COVER)
4	14-011	6	CLAMP, HOSE FUEL # 6
5	21-038	1	ELL, STREET 1/8 IN BRASS
6	21-007	2	FTTG, BRB 1/8P X 5/16 H BR
7	21-039	2	ELL, 1/4 IN LG STREET BRASS
8	21-006	4	FTTG, BRB 1/4P X 5//16H BR
9	21-086	2	FTTG, BULKHEAD 1/4 IN BRASS

**1997-2002 DODGE FULL SIZE VAN FUEL LINE INSTALLATION**

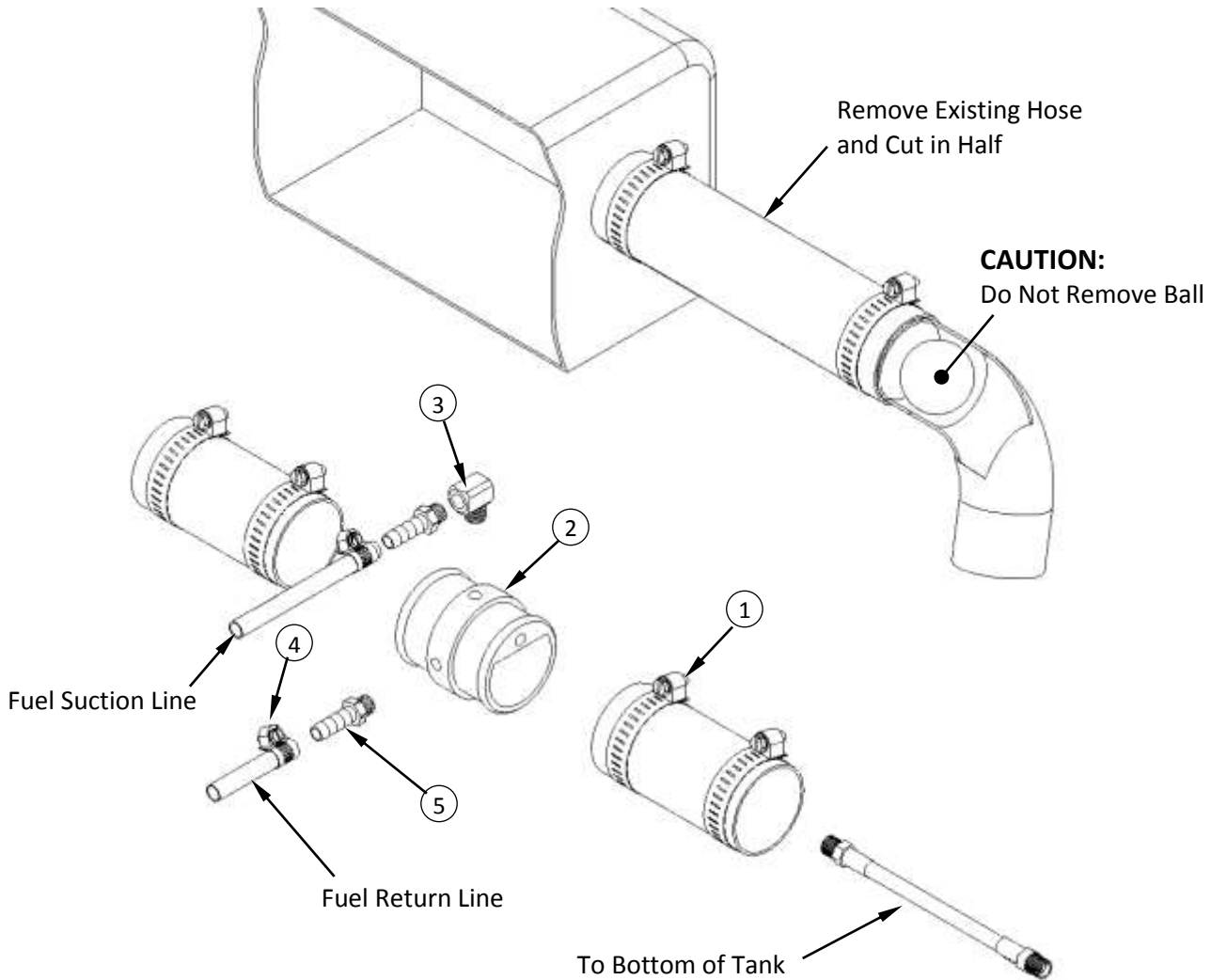

**69-004FI KIT, FUEL HOOKUP CHEVY/DODGE FI**

Item No.	Part Number	Qty	Description
1	14-010	2	CLAMP, HOSE # 32
2	66-030	1	ADAPTOR, FUEL NECK(CHEVY)
3	21-038	1	ELL, STREET 1/8 IN BRASS
4	14-011	6	CLAMP, HOSE FUEL # 6
5	21-007	2	FTTG, BRB 1/8P X 5/16 H BR
6	18-028	1	HOSE, 3/16 X 25 (1/8P X 1/8P NO COVER)
7	21-086	2	FTTG, BULKHEAD 1/4 IN BRASS
8	21-006	4	FTTG, BRB 1/4P X 5//16H BR
9	21-039	2	ELL, 1/4 IN LG STREET BRASS

## **FUEL LINE BULKHEAD INSTALLATION** (Inside Vehicle)

1. Select an appropriate location on the vehicle floor away from operator or maintenance traffic and away from contact with any accessories or tools while in use or transit. Make sure your hole is within adequate reach of the supplied hose in the finished assembly.
2. Drill a 3/4 inch hole through the vehicle floor at the location chosen for the bulkhead connector.
3. Install the bulkhead connector by inserting the fitting and tightening the nut and lock washer on the opposite side of the vehicle floor.
4. Inside the vehicle, attach the hose barb fitting and connect the fuel line from the console.
5. Drill a 1/2 inch hole nearby the bulkhead fitting for the fuel pump electrical extension harness to pass through.

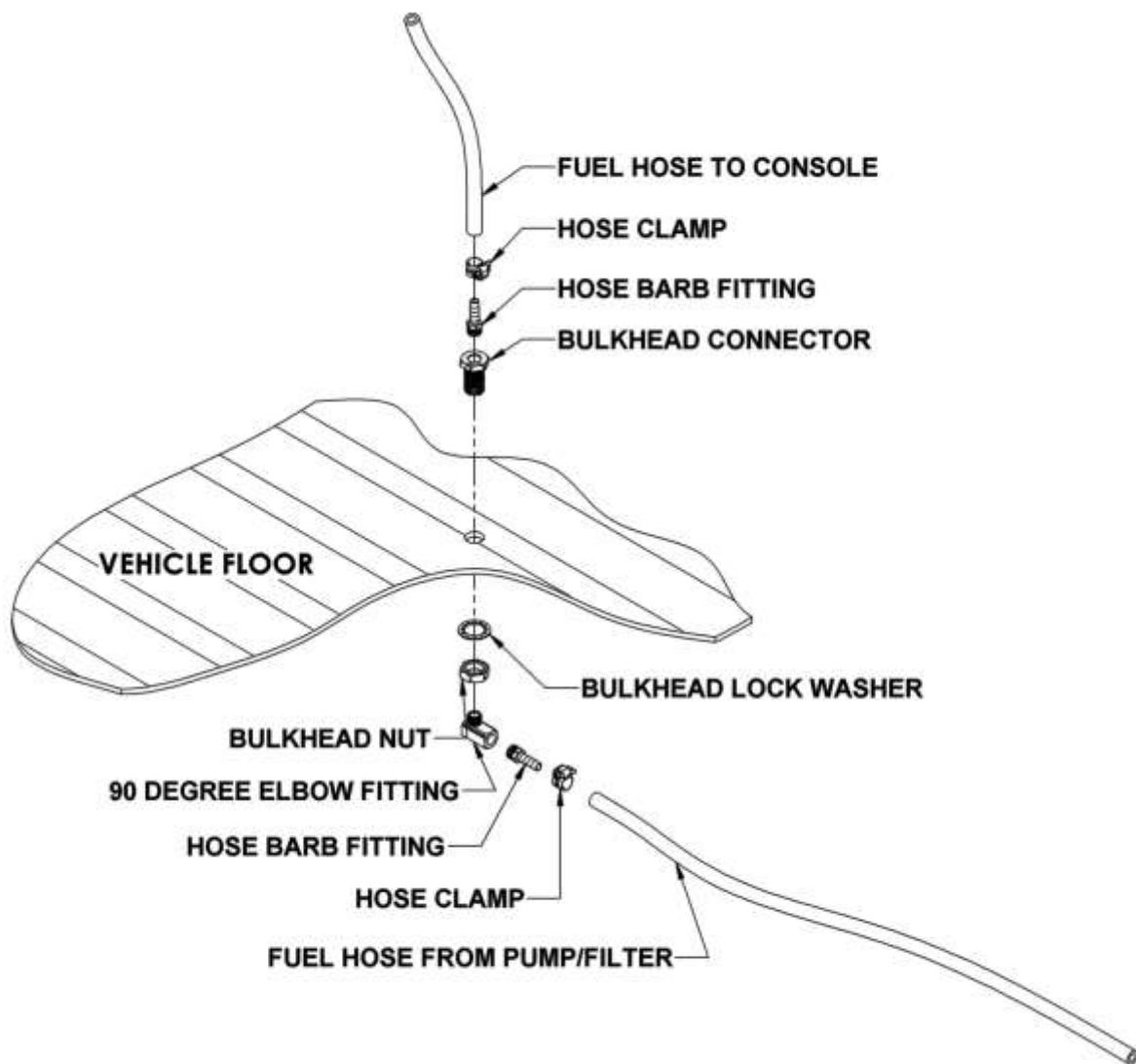

Figure 1. Fuel Line Bulkhead Assembly

## **FUEL PUMP ASSEMBLY INSTALLATION** (Underneath the Vehicle Floor)

1. Locate an appropriate location for the fuel pump assembly housing to mount underneath the vehicle that will not cause damage to the vehicle or compromise the fuel line routing or components.
2. Remove the housing lid from the fuel pump assembly.
3. Use the supplied Tek screws to install the lid of the fuel pump housing to the vehicle.

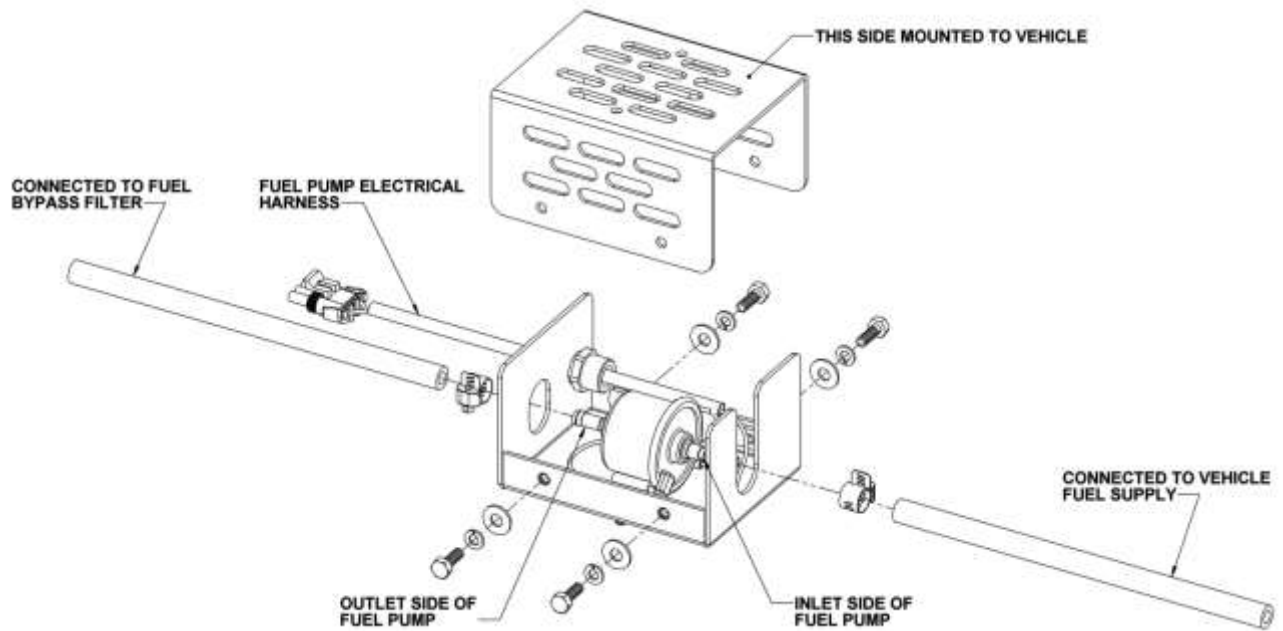

Figure 2. Fuel Pump Assembly Detail

## **FUEL SUPPLY & RETURN LINE INSTALLATION** (Underneath the Vehicle Floor)

1. Refer to the transfer flow kit instructions found with the appropriate kit for your vehicle.
2. Connect the fuel line from the transfer flow kit to the inlet side of the fuel pump.
3. Connect the outlet side of the fuel pump to the inlet side of the fuel bypass filter.
4. Connect the return line from the bypass filter return port back to the vehicle fuel supply.

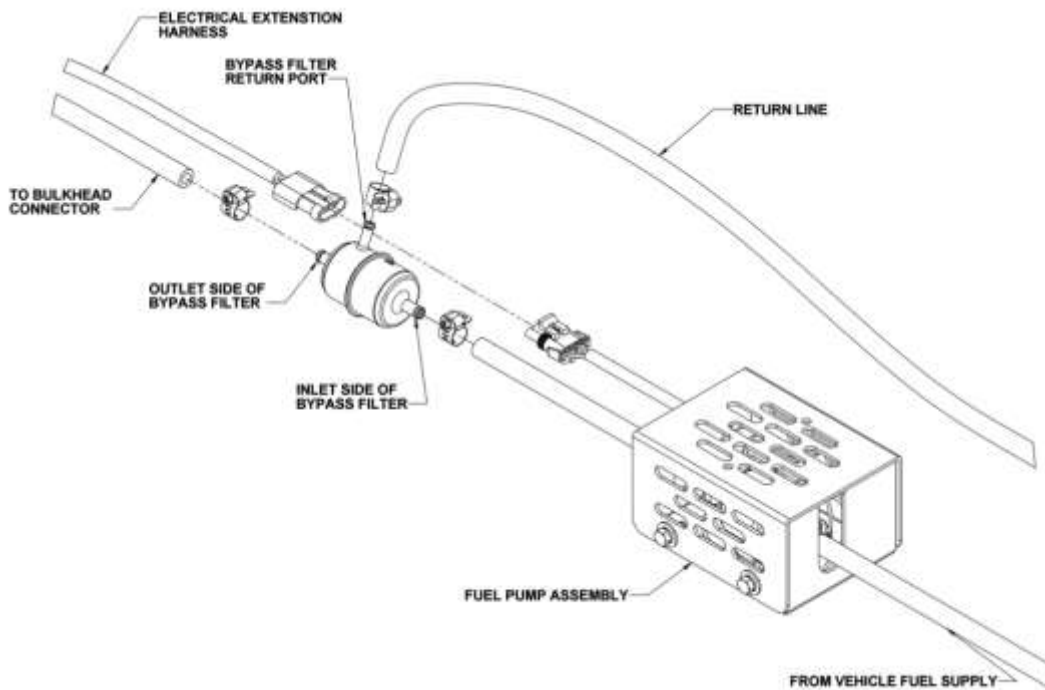

Figure 3. Fuel Pump and Filter Detail

5. Attach the 90 degree elbow and hose barb fittings to the bulkhead connector underneath the vehicle.
6. Connect a segment of hose between the outlet side of the fuel bypass filter to the hose barb fitting.
7. Ensure that all hose clamps are properly tightened.
8. Connect the electrical extension harness to the fuel pump harness, running the other end up through a hole in the floor of the vehicle, connecting to the console harness.

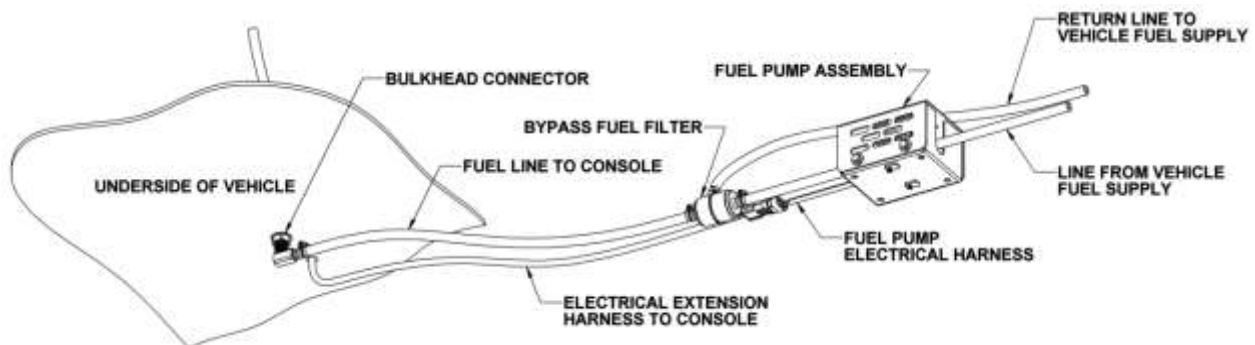

Figure 4. Vehicle Underside Fuel Line Installation

**ENGINE DIAGNOSTIC CODES**

<b>ZEEMS-3 Fault Code List</b>							
<b>Date:</b> 2/23/15							
<b>Notes:</b>							
1	The MIL will stay on for 3 start-stop cycles after a fault is detected. The MIL will turn off on the 4th cycle if the fault has not recurred during the previous 3 cycles.						
2	Faults may be retrieved and cleared with the PC Service Tools by: - <b>GCP Display:</b> Double-click on the fault at the bottom of the "Faults" page. - <b>SparroWatch:</b> Click on the "DTC" tab or type F6, then click "Action > Clear Diagnostic Trouble Codes" on the header menu.						
3	The ECUs clear faults automatically after 20 engine start-stop cycles if the fault has not recurred during the 20 cycles.						
4	<p><b>Code Definitions:</b></p> <p>DTC (Diagnostic Trouble Codes) are reported by the GCP Display PC tool. Pcodes are reported by the SparroWatch PC tool. Numbers match the DTC's.</p> <p>CAN (Controller Area Network) SPNs (Specific Parameter Number) and FMIs (Failure Mode Indicator) are reported by Zenith's CAN-Tach and other J1939 CAN readers.</p> <p>MIL (Malfunction Indicator Lamp) Flash Codes are flashed over the MIL when the procedure defined in Note #5 is performed.</p>						
5	<p>Fault codes can be flashed on the MIL by installing the shorting cap or grounding the COM/DIAGNOSTIC connector pin specified below, then keying on without starting the engine. The ECU flashes the leader code, then the fault code(s), then trailer code. Each code is repeated 3 times.</p> <p>On the 410, 428, &amp; 644 engines, install the ZPP-C282-457 shorting cap on the COMM connector or ground the Orange/Black pin of the COM connector.</p> <p>On the 416, 420, &amp; 640 engines, install the ZPP-C282-455 shorting cap on the COMM connector or ground the Brown/White pin of the COM/DIAGNOSTIC connector.</p>						



SECTION SIX – GUIDES AND DIAGRAMS

DTC/ Pcode	Fault	410, 428, & 644 (Sparrow ECU)			416, 420, & 640 (GCP ECU)		
		CAN SPN	CAN FMI	MIL Flash Code	CAN SPN	CAN FMI	MIL Flash Code
	<b>Leader/Trailer Code</b>			111			111
(P0) 016	CRANK or CAM could not synchronize during start		NA		636	8	216
(P0) 107	MAP Signal open or shorted to ground	106	4	127	106	4	127
(P0) 108	MAP signal shorted high	106	3	128	106	16	128
(P0) 112	IAT Sensor Low/Shorted Input	105	4	112	105	4	112
(P0) 113	IAT Sensor High/Open Input	105	3	113	105	3	113
(P0) 116	ECT higher than warning threshold		NA		110	15	116
(P0) 117	ECT Sensor Low/Shorted Input	110	4	117	110	4	117
(P0) 118	ECT Sensor High/Open Input	110	3	118	110	3	118
(P0) 121	TPS 1-2 voltage difference higher than expected		NA		51	1	121
(P0) 122	Throttle Position Signal 1 low voltage	3464	4	122	51	4	122
(P0) 123	Throttle Position Signal 1 high voltage	3464	3	123	51	3	123
(P0) 131	O2 Bank 1 Sensor 1 Low Input	3225	4	131			NA
(P0) 132	O2 Bank 1 Sensor 1 High Input	3225	3	132			NA
(P0) 133	O2 Bank 1 Sensor 1 Slow Response	3225	10	133			NA
(P0) 134	O2 Bank 1 Sensor 1 No Activity	3225	14	134	724	10	134
(P0) 135	Front O2 sensor heater control fault			135	724	14	135
(P0) 137	Rear oxygen sensor low voltage	3235	4	137			NA
(P0) 138	Rear oxygen sensor high voltage	3235	3	138			NA
(P0) 141	Rear oxygen sensor heater control fault			141			NA
(P0) 151	Closed-loop LPG A/F is too lean		NA		520206	0	151
(P0) 152	Closed-loop LPG A/F is too rich		NA		520206	1	152
(P0) 154	Post-Cat O2 Signal No Activity		NA		520208	10	154
(P0) 155	Closed-loop gasoline bank 1 A/F is too lean		NA		520204	0	155
(P0) 156	Closed-loop gasoline bank 1 A/F is too rich		NA		520204	1	156
(P0) 165	Catalyst inactive on LPG		NA		520213	10	165
(P0) 166	Catalyst inactive on NG		NA		520214	10	166
(P0) 171	Pre-cat A/F is lean	1695	16	171	520200	0	171
(P0) 172	Pre-cat A/F is rich	1695	18	172	520200	1	172
(P0) 182	Gasoline Fuel Temp Sensor A Low Input		NA		174	4	182
(P0) 183	Gasoline Fuel Temp Sensor A High Input		NA		174	3	183
(P0) 187	LPG Fuel Temp Low Voltage		NA		520240	4	187
(P0) 188	LPG Fuel Temp High Voltage		NA		520240	3	188
(P0) 215	LP or NG fuel purge time exceeded following key-off			215			NA
(P0) 217	Engine Overheat Condition	110	0	217	110	0	217
(P0) 219	Engine Overspeed Condition	190	0	219	515	0	219
(P0) 221	TPS 1-2 voltage difference higher than expected		NA		51	0	221
(P0) 222	Throttle Position Signal 2 low voltage		NA		520251	4	222
(P0) 223	Throttle Position Signal 2 high voltage		NA		520251	3	223
(P0) 231	Fuel Pump Circuit Low	1075	4	231			NA
(P0) 232	Fuel Pump Circuit High	1075	3	232			NA
(P0) 261	Injector 1 Low/Open	648	4	261	651	5	261
(P0) 262	Injector 1 High/Short	648	3	262	651	6	262
(P0) 264	Injector 2 Low/Open	649	4	264	652	5	264
(P0) 265	Injector 2 High/Short	649	3	265	652	6	265
(P0) 267	Injector 3 Low/Open	650	4	267	653	5	267
(P0) 268	Injector 3 High/Short	650	3	268	653	6	268
(P0) 270	Injector 4 Low/Open	651	4	269	654	5	269
(P0) 271	Injector 4 High/Short	651	3	271	654	6	271
(P0) 273	Injector 5 Low/Open	652	4	273	655	5	273
(P0) 274	Injector 5 High/Short	652	3	274	655	6	274
(P0) 276	Injector 6 Low/Open	653	4	276	656	5	276
(P0) 277	Injector 6 High/Short	653	3	277	656	6	277
(P0) 287	Gasoline Fuel Pressure too low		NA		94	1	287
(P0) 288	Gasoline Fuel Pressure too high		NA		94	0	288
(P0) 291	Gasoline Fuel Pressure low voltage		NA		94	4	291
(P0) 292	Gasoline Fuel Pressure high voltage		NA		94	3	292
(P0) 315	FPP1 higher than IVS limit						315

SECTION SIX – GUIDES AND DIAGRAMS

DTC/ Pcode	Fault	410, 428, & 644 (Sparrow ECU)			416, 420, & 640 (GCP ECU)		
		CAN SPN	CAN FMI	MIL Flash Code	CAN SPN	CAN FMI	MIL Flash Code
(P0) 326	Knock signal excessive or erratic		NA		731	2	326
(P0) 327	Knock signal open or not present		NA		731	4	327
(P0) 336	CRANK signal noise		NA		636	2	336
(P0) 337	No CRANK signal		NA		636	4	337
(P0) 339	FPP1 lower than IVS limit						339
(P0) 340	Camshaft Position Sensor A (no signal)	190	3	342		NA	
(P0) 341	CAM signal noise		NA		723	2	341
(P0) 342	Camshaft Position Sensor A (no signal)		NA		723	4	342
(P0) 359	Fuel (LPG or NG) run-out longer than expected		NA		0	31	359
(P0) 421	Catalyst inactive on gasoline		NA		520211	10	421
(P0) 523	Oil pressure signal open or shorted high	100	3	523		NA	
(P0) 524	Engine Oil Pressure Too Low	100	2	524	100	1	524
(P0) 562	Battery Voltage Low	158	4	562	168	17	562
(P0) 563	Battery Voltage High	158	3	563	168	15	563
(P0) 601	Microprocessor failure - FLASH		NA		628	13	621
(P0) 603	Keep Alive Memory Error	627	2	613		NA	
(P0) 604	Microprocessor failure - RAM		NA		630	12	624
(P0) 606	Microprocessor failure - COP		NA		629	31	626
(P0) 615	Starter relay fault	677	31	615	1321	5	615
(P0) 616	Starter relay control short to GND		NA		1321	4	616
(P0) 617	Starter relay coil short to 12V		NA		1321	3	617
(P0) 627	Gasoline fuel pump relay control wire open		NA		1348	5	627
(P0) 628	Gasoline fuel pump relay control wire short to ground		NA		1348	4	628
(P0) 629	Gasoline fuel pump relay control wire short to 12 V		NA		1348	3	629
(P0) 637	Pin 85 (AUX_PWM4) open/short to GND		NA		700	5	637
(P0) 638	Electronic throttle control performance	51	7	638		NA	
(P0) 642	5V Reference #1 (pin 9) voltage low			642	1079	4	642
(P0) 643	5V reference #1 voltage high		NA		1079	3	643
(P0) 650	Malfunction Indicator Lamp Control open	624	11	651	1213	5	651
(P0) 652	5V Reference #2 voltage low		NA		1080	4	652
(P0) 653	5V Reference #2 voltage high		NA		1080	3	653
(P0) 655	Engine Protection Lamp fault	623	31	655		NA	
(P0) 681	Customer Auxiliary Shutdown #1			681		NA	
(P0) 685	Power relay coil open		NA		1485	5	685
(P0) 686	Power relay short to GND		NA		1485	4	686
(P0) 687	Power relay short to 12V		NA		1485	3	687
(P0) 1122	Throttle Actuator TPS A Low Input	000051	4	122		NA	
(P0) 1123	Throttle Actuator TPS A High Input	000051	3	123		NA	
(P0) 1153	Closed-loop NG A/F is too lean		NA		520207	0	153
(P0) 1154	Closed-loop NG A/F is too rich		NA		520207	1	159
(P0) 1161	LPG Adaptive-learn A/F is too lean		NA		520202	0	161
(P0) 1162	LPG Adaptive-learn A/F is too rich		NA		520202	1	162
(P0) 1163	NG Adaptive-learn A/F is too lean		NA		520203	0	163
(P0) 1164	NG Adaptive-learn A/F is too rich		NA		520203	1	164
(P0) 1171	EPR delivery pressure higher than expected		NA		520260	0	371
(P0) 1172	EPR delivery pressure lower than expected		NA		520260	1	372
(P0) 1173	EPR-ECU communications lost		NA		520260	31	173
(P0) 1174	EPR voltage supply high		NA		520260	3	174
(P0) 1175	EPR voltage supply low		NA		520260	4	175
(P0) 1176	EPR internal actuator fault detected		NA		520260	12	176
(P0) 1177	EPR internal circuitry fault detected		NA		520260	12	177
(P0) 1178	EPR internal communications fault detected		NA		520260	12	178
(P0) 1219	Customer specified engine overspeed limit exceeded	190	15	229		NA	
(P0) 1222	Throttle Actuator TPS B Low Input	000051	4	222		NA	
(P0) 1223	Throttle Actuator TPS B High Input	000051	3	223		NA	
(P0) 1272	Accelerator pedal signal low voltage	000091	4	282		NA	
(P0) 1273	Accelerator pedal signal high voltage	000091	3	283		NA	
(P0) 1515	AUX 5V ANALOG INPUT 4 open or high		NA		520215	3	515

SECTION SIX – GUIDES AND DIAGRAMS

DTC/ Pcode	Fault	410, 428, & 644 (Sparrow ECU)			416, 420, & 640 (GCP ECU)		
		CAN SPN	CAN FMI	MIL Flash Code	CAN SPN	CAN FMI	MIL Flash Code
(P0) 1516	AUX 5V ANALOG INPUT 4 low		NA		520215	4	516
(P0) 1517	AUX 5V ANALOG INPUT 3 open or high		NA		520218	3	517
(P0) 1518	Throttle actuator zero cycle incomplete		NA		520218	3	518
(P0) 1541	AUX 5V ANALOG INPUT 1 high / Low Coolant Shutdown (On units Equipped)		NA		520219	3	541
(P0) 1542	AUX 5V ANALOG INPUT 1 low or open		NA		520219	4	542
(P0) 1543	AUX 5V ANALOG INPUT 2 high or open		NA		520220	3	543
(P0) 1544	AUX 5V ANALOG INPUT 2 low		NA		520220	4	544
(P0) 1551	AUX DIGITAL INPUT 1 high		NA		520222	3	551
(P0) 1552	AUX DIGITAL INPUT 1 low		NA		520222	4	552
(P0) 1553	AUX DIGITAL INPUT 2 high		NA		520223	3	553
(P0) 1554	AUX DIGITAL INPUT 2 low		NA		520223	4	554
(P0) 1555	AUX DIGITAL INPUT 3 high		NA		520224	3	555
(P0) 1556	AUX DIGITAL INPUT 3 low		NA		520224	4	556
(P0) 1562	Extreme overvoltage - ECM damage possible	158	0	564			NA
(P0) 1563	AUX 5V ANALOG INPUT 5 open or high		NA		TBD	TBD	563
(P0) 1564	AUX 5V ANALOG INPUT 5 low		NA		TBD	TBD	564
(P0) 1602	EEPROM version incorrect	520194	1	622			NA
(P0) 1605	EEPROM calibration information lost	520196	1	625			NA
(P0) 1609	Calibration mismatch with firmware	630	13	629			NA
(P0) 1612	Watchdog processor blocked outputs (RTI 1)		NA		629	31	712
(P0) 1613	Microprocessor failure - RTI 2		NA		629	31	713
(P0) 1614	Microprocessor failure - RTI 3		NA		629	31	714
(P0) 1615	Microprocessor failure - A/D		NA		629	31	715
(P0) 1616	Microprocessor failure - Interrupt		NA		629	31	716
(P0) 1619	Unauthorized calibration upload or update	520197	1	619			NA
(P0) 1644	MIL control short to GND		NA		1213	4	644
(P0) 1645	MIL control short to 12V		NA		1213	3	645
(P0) 1681	Customer Auxiliary Shutdown #1 / Low coolant level shutdown (428, 644)	970	31	681	970	31	681
(P0) 1682	Customer Auxiliary Shutdown #2	TBD	TBD	682			NA
(P0) 1683	Customer Auxiliary Shutdown #3	TBD	TBD	683			NA
(P0) 2115	APP1 indicates off-idle while IVS indicates idle		NA		91	3	315
(P0) 2121	APP1/FPP1 lower than APP2/FPP2	91	18	321	91	18	321
(P0) 2122	APP1/FPP1 signal low voltage	91	4	322	91	4	322
(P0) 2123	APP1/FPP1 signal high voltage	91	3	323	91	3	323
(P0) 2126	APP1/FPP1 higher than APP2/FPP2	91	16	426	91	16	426
(P0) 2127	APP2/FPP2 signal low voltage	29	3	427	29	3	427
(P0) 2128	APP2/FPP2 signal high voltage	29	4	328	29	4	328
(P0) 2130	IVS stuck at idle, APP 1/2 mismatch		NA		558	5	332
(P0) 2138	TPS D/E Performance (idle validation switch)			321			
(P0) 2131	IVS stuck at off-idle, APP 1/2 mismatch		NA		558	6	331
(P0) 2139	APP1 indicates idle while IVS indicates off-idle		NA		91	1	339
(P0) 2300	Ignition coil A low current	1268	5	411			NA
(P0) 2301	Ignition coil A high current	1268	6	412			NA
(P0) 2302	Ignition coil A secondary open	1268	31	413			NA
(P0) 2303	Ignition coil B low current	1269	5	421			NA
(P0) 2304	Ignition coil B high current	1269	6	422			NA
(P0) 2305	Ignition coil B secondary open	1269	31	423			NA
(P0) 2306	Ignition coil C low current	1270	5	431			NA
(P0) 2307	Ignition coil C high current	1270	6	432			NA
(P0) 2308	Ignition coil C secondary open	1270	31	433			NA
(P0) 2309	Ignition coil D low current	1271	5	441			NA
(P0) 2310	Ignition coil D high current	1271	6	442			NA
(P0) 2311	Ignition coil D secondary open	1271	31	443			NA